

Example: (DeCarlo, Lin Example 9.7)

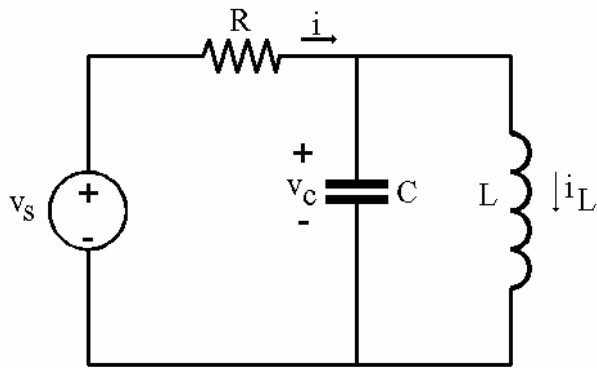

State variables: $v_c(t)$
 $i_L(t)$

State equations:

$$i = i_c + i_L$$

$$i_c = C \frac{dv_c}{dt}$$

$$v_L = L \frac{di_L}{dt}$$

KCL: $i = i_L + i_c$

KVL: $v_c = v_L$

$$v_L = Ri + v_c$$

Hence: $v_s = R \cdot (i_L + i_c) + v_c$

$$i_c = C \frac{dv_c}{dt}$$

$$v_c = L \frac{di_L}{dt}$$

or:

$$i_L + C \frac{dv_c}{dt} + \frac{1}{R} v_c = \frac{1}{R} \cdot v_s$$

$$\frac{di_L}{dt} = \frac{1}{L} \cdot v_c$$

Finally,

$$\frac{dv_c}{dt} = -\frac{1}{RC} \cdot v_c - \frac{1}{C} \cdot i_L + \frac{1}{RC} \cdot v_s$$

$$\frac{di_L}{dt} = \frac{1}{L} \cdot v_c$$

state equations

Matrix equation:

$$\frac{d}{dt} \begin{bmatrix} v_c \\ i_L \end{bmatrix} = \begin{bmatrix} -\frac{1}{RC} & -\frac{1}{C} \\ \frac{1}{L} & 0 \end{bmatrix} \cdot \begin{bmatrix} v_c \\ i_L \end{bmatrix} + \begin{bmatrix} \frac{1}{RC} \\ 0 \end{bmatrix} \cdot v_s$$

Note that once we know v_c and i_L , all other circuit variables can be found from them.

Example:
$$i = \frac{v_s - v_c}{R}$$

in matrix form:
$$i = \begin{bmatrix} -\frac{1}{R} \\ 0 \end{bmatrix} \cdot \begin{bmatrix} v_c \\ i_L \end{bmatrix} + \frac{1}{R} \cdot v_s$$

canonical form:
$$\frac{d}{dt} x = Ax + Bu$$

where $x = \{\text{vector of the state variable}\}$, $A = \{\text{matrix}\}$, $B = \{\text{column vector}\}$ and $u = \{\text{input}\}$

Zero state response:

- all initial conditions set to 0

$$v_c(0^-) = 0$$

$$i_L(0^-) = 0$$

Hence:

$$v_c(0^+) = 0$$

$$i_L(0^+) = 0$$

Zero input response:

- $v_s(t) \equiv 0$

- trivial solution if all initial conditions are set to 0

- non-trivial solution if

$$v_c(0^-) \neq 0 \text{ and/or } i_L(0^-) \neq 0$$

therefore

$$v_c(0^+) \neq 0 \text{ and/or } i_L(0^+) \neq 0$$

Zero input response: solution to the homogeneous DE (RHS $\equiv 0$)

Hence, zero input response is equivalent to the homogeneous solution of the DE. Zero state response is the equivalent to the sum of the particular solution and the homogeneous solution of the DE:

$$x(t) = K_1 e^{s_1 t} + K_2 e^{s_2 t} + x_p(t)$$

K_1 and K_2 : initial conditions

$x_p(t) \equiv \text{zero}$ if input is zero

In our example:

$$\frac{dx}{dt} = Ax + Bu$$

$$A = \begin{pmatrix} -\frac{1}{RC} & -\frac{1}{C} \\ \frac{1}{L} & 0 \end{pmatrix}$$

Assume that the solution is $x = e^{st}$, for $u \equiv 0$ (homogeneous case)

$$\frac{dx}{dt} = s \cdot e^{st}$$

$$s \cdot e^{st} \cdot I = A \cdot e^{st} \quad \text{where } I = \{\text{identity matrix}\}$$

$$(s \cdot I - A) \cdot e^{st} = 0 \Rightarrow \det(s \cdot I - A) = 0$$

$$\det \begin{bmatrix} s + \frac{1}{RC} & \frac{1}{C} \\ -\frac{1}{L} & s \end{bmatrix} = 0$$

$$s \left(s + \frac{1}{RC} \right) + \frac{1}{LC} = 0$$

$$s^2 + \frac{1}{RC}s + \frac{1}{LC} = 0$$

Again:

$$s_{1/2} = -\frac{1}{2RC} \pm \sqrt{\left(\frac{1}{2RC}\right)^2 - \frac{1}{LC}} \quad \text{Note: the same as in the series RLC case}$$

Let us find $v_c(t)$, when $v_s(t)$ is a step function:

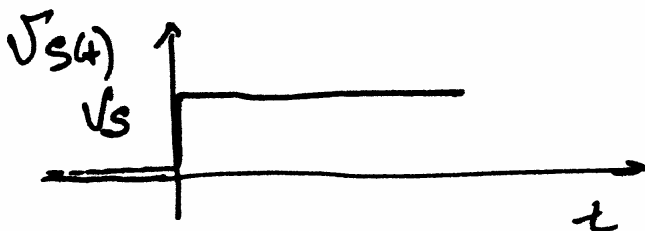

$$v_s(t) = V_s \cdot u(t)$$

$$= 0, \quad t < 0$$

$$V_s, \quad t \geq 0$$

$$v_c(t) = v_c(t) + v_{cp}(t)$$

Let us consider zero state response: all initial conditions are set to zero

$$v_{ch}(t) = k_1 e^{s_1 t} + k_2 e^{s_2 t}$$

$$v_{cp}(t) = ? \quad (\text{constant, because the } V_s \text{ is constant})$$

Assume

$$v_{cp}(t) = A$$

$$\text{DE: } \frac{dv_c}{dt} = -\frac{1}{RC} \cdot v_c - \frac{1}{L} i_L + \frac{1}{RC} \cdot v_s$$

$$\frac{di_L}{dt} = \frac{1}{L} v_c$$

Assume also that $i_{Lp}(t)$ is a constant B

$$\text{then: } 0 = -\frac{1}{RC} \cdot A - \frac{1}{L} \cdot B + \frac{1}{RC} \cdot v_s$$

$$0 = \frac{1}{L} \cdot A \Rightarrow A \equiv 0$$

Hence:

$$v_c(t) = k_1 e^{s_1 t} + k_2 e^{s_2 t}$$

$$v_c(0^-) = 0$$

$$v_c(0^+) = k_1 + k_2 \Rightarrow k_1 + k_2 = 0$$

$$\frac{dv_c}{dt} = k_1 s_1 e^{s_1 t} + k_2 s_2 e^{s_2 t}$$

$$\left. \frac{dv_c}{dt} \right|_0 = k_1 s_1 + k_2 s_2$$

From the DE:

$$\frac{dv_c}{dt} = -\frac{1}{RC} \cdot v_c - \frac{1}{L} i_L + \frac{1}{RC} \cdot v_s$$

$$\left. \frac{dv_c}{dt} \right|_{0^+} = \frac{1}{RC} \cdot v_s$$

$$k_1 s_1 + k_2 s_2 = \frac{1}{RC} \cdot v_s$$

Hence:

$$k_1 = \frac{1}{RC(s_1 - s_2)} \cdot v_s$$

$$k_2 = \frac{1}{RC(s_2 - s_1)} \cdot v_s$$

Case 1: $s_1 \neq s_2$: real, negative.

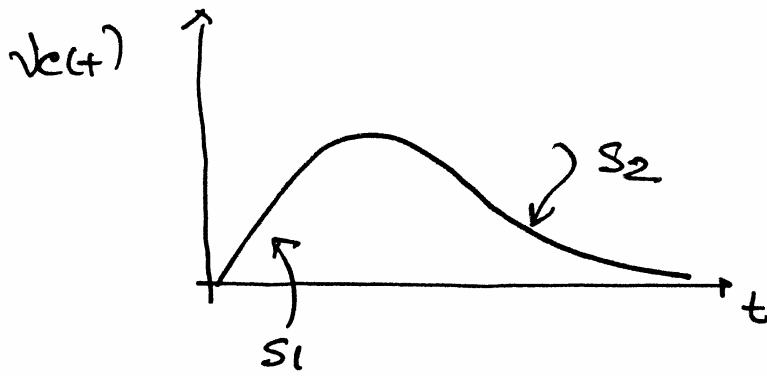

$$s_1 = -\frac{1}{2RC} + \sqrt{\left(\frac{1}{2RC}\right)^2 - \frac{1}{LC}}$$

$$s_2 = -\frac{1}{2RC} - \sqrt{\left(\frac{1}{2RC}\right)^2 - \frac{1}{LC}}$$

$$s_1 - s_2 = 2\sqrt{\left(\frac{1}{2RC}\right)^2 - \frac{1}{LC}}$$

$$v_c(t) = \frac{V_s}{2RC\sqrt{\left(\frac{1}{2RC}\right)^2 - \frac{1}{LC}}} (e^{s_1 t} - e^{s_2 t})$$

Note: $s_1 > s_2$

Roots:

s-plane

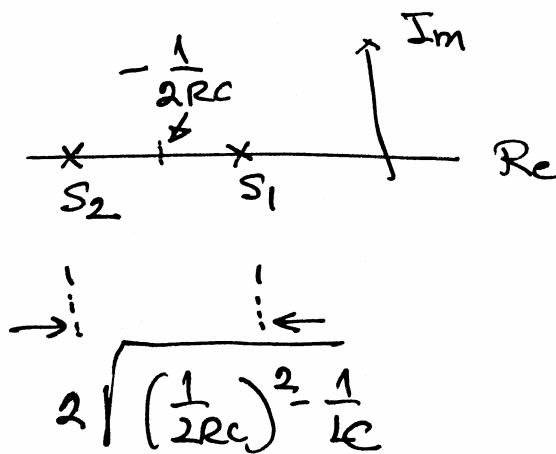

s_1 : closer to the origin : slowly decaying term

s_2 : further from the origin : faster decaying term

Case 2: $s_1 \neq s_2$: complex, conjugate

Why do they come in pairs?

General property of systems with real coefficients

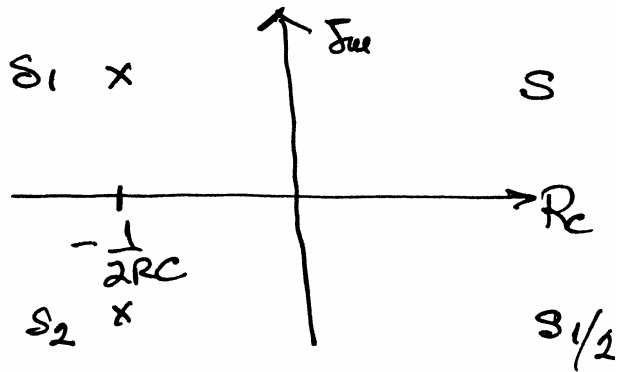

$$s_{1/2} = -\frac{1}{2RC} \pm j\sqrt{\frac{1}{LC} - \left(\frac{1}{2RC}\right)^2}$$

$$v_c(t) = \frac{V_s}{2jRC\sqrt{\frac{1}{LC} - \left(\frac{1}{2RC}\right)^2}} \cdot e^{-\frac{t}{2RC}} \left(e^{j\sqrt{\frac{1}{LC} - \left(\frac{1}{2RC}\right)^2}t} - e^{-j\sqrt{\frac{1}{LC} - \left(\frac{1}{2RC}\right)^2}t} \right)$$

Euler's formula:

$$e^{jat} - e^{-jat} = [\cos(at) + j\sin(at)] - [\cos(at) - j\sin(at)] = 2j\sin(at)$$

Hence:

$$v_c(t) = \frac{V_s}{RC\sqrt{\frac{1}{LC} - \left(\frac{1}{2RC}\right)^2}} \cdot e^{-\frac{t}{2RC}} \sin\left(\sqrt{\frac{1}{LC} - \left(\frac{1}{2RC}\right)^2}t\right)$$

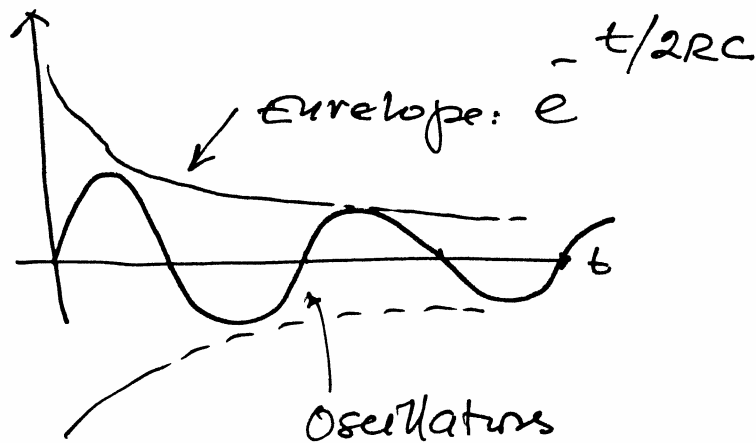

$$\text{frequency} = \sqrt{\frac{1}{LC} - \left(\frac{1}{2RC}\right)^2}$$

$$s : \text{period} = \frac{1}{\sqrt{\frac{1}{LC} - \left(\frac{1}{2RC}\right)^2}}$$

imaginary part:

larger frequencies: faster oscillations (further from the origin)

real part:

further from the origin: faster decay

Case 3: $s_1 = s_2 = -\frac{1}{2RC}$

$$\left(\frac{1}{2RC}\right)^2 - \frac{1}{LC} = 0$$

$$LC = (2RC)^2$$

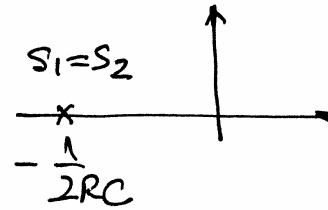

$$v_c(t) = (k_1 + k_2 t)e^{st}$$

$$v_c(0) = 0 \Rightarrow k_1 = 0$$

$$\left.\frac{dv_c}{dt}\right|_0 = \frac{V_s}{RC}$$

$$\frac{dv_c}{dt} = k_2 e^{st} + s(k_1 + k_2 t)e^{st}$$

$$\left.\frac{dv_c}{dt}\right|_0 = k_2 + sk_1$$

$$k_2 = \frac{V_s}{RC}$$

Hence:

$$v_c(t) = \frac{V_s}{RC} t e^{-\frac{t}{2RC}}$$

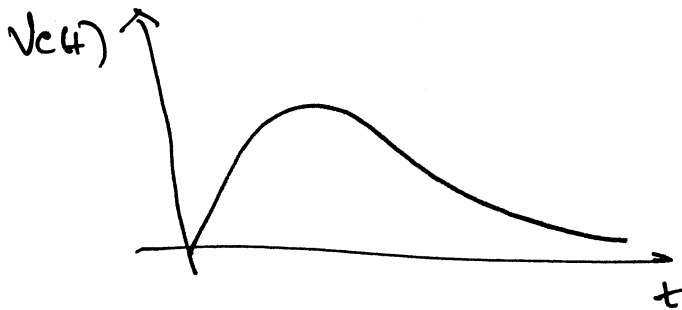

root further from the origin produces faster response

In summary:

- obtain DE: KCL, KVL, constitutive relationship for R, C, L
- from known initial conditions, get the values of state variables at 0+
- from known initial conditions *and* the DE, find values of the derivatives of state variables at 0+
- conjecture the particular (steady-state) solution by looking at the forcing (source) function

Solution: $x(t) = xh(t) + xp(t)$

- all done in the time domain.

Is there a simpler way?

Yes: by using transformation to a frequency (s) domain (Laplace transforms).