

ENSC 427: COMMUNICATION NETWORKS

ZIGBEE MESH NETWORK SIMULATION USING OPNET AND STUDY OF ROUTING SELECTION Spring 2009

FINAL PROJECT

Sam Leung
Wil Gomez
Jung Jun Kim
<http://www.sfu.ca/~mingl/>
mingl@sfu.ca
wgomez@sfu.ca
jkind@sfu.ca

ABSTRACT

ZigBee, formally known as IEEE 802.15.4-2006 standard, is becoming a popular way to create wireless personal area network (WPAN) due to its low power consumption and scalability. ZigBee ad-hoc mesh networks are designed to support a large number of nodes (>64,000) with dynamic routing in case of a node failure. This project will simulate and explore the performance of ZigBee WPAN's under various conditions using OPNET.

TABLE OF CONTENTS

ABSTRACT	i
TABLE OF CONTENTS	ii
LIST OF FIGURES	iii
LIST OF TABLES	iii
ACRONYMS AND ABBREVIATIONS	iv
1 Introduction	1
1.1 Project Scope	1
2 ZigBee Overview.....	2
2.1 ZigBee Specifications	2
2.2 ZigBee Layers	2
2.2.1 Application Layer	3
2.2.2 Network Layer	3
2.2.4 Medium Access Control Sub-Layer	3
2.2.5 Physical Layer	4
2.3 Network Topologies	4
2.3.1 Star Topology	5
2.3.2 Tree Topology	5
2.3.3 Mesh Topology	6
3 ZigBee Simulation Using OPNET.....	6
3.1 Traffic with Single Router	6
3.2 Verification of ZigBee’s Self-Healing Mechanism upon Router Failure	10
3.3 Traffic Stability in Presence of Moving End-Devices – CBR	15
3.4 Assessing Network Performance with Stationary End-Devices – VBR	17
3.5 Testing the ZigBee OPNET Model Limits – Adding Additional End Devices ..	20
4 DISCUSSIONS AND CONCLUSION	23
4.1 OPNET ZigBee Model Limitations	23
4.2 What We Learned	23
5 REFERENCES	24

LIST OF FIGURES

Figure 1 – Overview of ZigBee Layers [7]	2
Figure 2 - Legend for ZigBee Devices	5
Figure 3 – Star Topology [6].....	5
Figure 4 – Tree Topology [6].....	5
Figure 5 – Mesh Topology [6]	6
Figure 6 - Single Router Available Scenario	7
Figure 7 – Traffic from end devices to destination coordinator	8
Figure 8 – Traffic sent and received by the two routers.....	8
Figure 9 - End to End delay from end devices to coordinator (As Is)	9
Figure 10 – End to End delay from end devices to coordinator (Average).....	9
Figure 11 – Traffic path prior router failure.....	10
Figure 12 - Traffic path after router failure.....	11
Figure 13 – Traffic Sent by end devices and received by routers	12
Figure 14 – Traffic from routers to coordinator (overlaid view).....	13
Figure 15 – Traffic from routers to coordinator (stacked view)	13
Figure 16 – End to End delay from end devices to coordinator (As Is).....	14
Figure 17 – End to End delay from end devices to coordinator (Average).....	14
Figure 18 - Traffic and Trajectory Path.....	15
Figure 19 - Traffic Sent From End Devices & Routers to Coordinator	16
Figure 20 - Traffic Sent From End Devices & Routers to Coordinator	16
Figure 21 – End-to-end delay showing packet drop around 5minute simulated time (As Is).....	16
Figure 22 – Same layout as scenario 3.1 using variable packet rate	17
Figure 23 – Traffic sent by end devices to destination coordinator with route traffic	18
Figure 24 – Traffic Sent From End Devices to Coordinator.....	19
Figure 25 – End to End delay from End Devices to Coordinator (As Is).....	19
Figure 26 – End to End delay from End Devices to Coordinator (Time Average)	20
Figure 27 – Case of two routers and three end devices	20
Figure 28 – Traffic sent by the end devices and received by the coordinator .	21
Figure 29 – Case of single router and three end devices.....	21
Figure 30 – Traffic from three end devices dropped en route	22

LIST OF TABLES

Table 1 – General ZigBee Specifications	2
Table 2: Frequency Bands used in 802.15.4[1]	4

ACRONYMS AND ABBREVIATIONS

ACL	Access Control List
AES	Advanced Encryption Standard
CBR	Constant Bit Rate
CSMA/CA	Carrier Sense Multiple Access/Collision Avoidance
ETE	End-to-End
HVAC	Heating, Ventilation and Air Conditioning
IEEE	Institute of Electrical and Electronics Engineers
ISM	Industrial, Scientific and Medical
LR-WPAN	Low Rate – Wireless Personal Area Network
MAC	Medium Access Control
PAN	Personal Area Network
PER	Packet Error Rate
VBR	Variable Bit Rate
ZDO	ZigBee Device Object

1 Introduction

Use of Wireless Personal Area Networks (WPAN) has steadily grown in recent years. Its popularity comes from the convenience of using wireless signals in open areas such as office space or home rather than having to lay out wires. Removing the constraints of length and troublesome physical installation of wires, wireless solutions provide much more diversity and potentially reduced cost.

ZigBee (IEEE 802.15.4-2006 standard) is a category in the IEEE 802 family, along with some of the well-known protocols such as Wi-Fi, Bluetooth which uses the 2.4 GHz industrial, and scientific and medical (ISM) radio band. ZigBee also utilizes 868 MHz and 915 MHz in different parts of the world according to local standards [1]. Unlike Wi-Fi and Bluetooth, ZigBee was developed for low-rate WPAN (LR-WPAN) which feature long battery life by having low data rates.

The ZigBee protocol was designed to provide static, dynamic, or mesh network topologies supporting up to 65,000 nodes across large areas for industrial use. In order to handle faults caused by various environmental effects, the ZigBee protocol provides a self-healing ability for the network to detect and recover from network or communication link faults without human intervention [1]. This is done through certain features of the ZigBee protocol such as clear channel assessment, retries and acknowledgments, and collision avoidance.

1.1 Project Scope

The primary goal of this project is to better understand the use of OPNET simulation tool as well as to study the protocol of interest, ZigBee. In order to achieve these goals this project will provide a brief overview of what ZigBee protocol contains, and simulate several simple ZigBee WPAN networks while altering certain parameters using OPNET.

2 ZigBee Overview

2.1 ZigBee Specifications

	ZigBee 802.15.4
Transmission Range (meters)	1 – 100
Battery Life (days)	100 – 1,000
Network Size (# of nodes)	> 64,000
Throughput (kb/s)	20 - 250

Table 1 – General ZigBee Specifications

2.2 ZigBee Layers

ZigBee consists of four layers. The top two (Application and Network) layers specifications are provided by the ZigBee Alliance to provide manufacturing standards. The bottom two (Medium Access Control and Physical) layers specifications are provided by the IEEE 802.15.4-2006 standard to ensure coexistence without interference with other wireless protocols such as Wi-Fi.

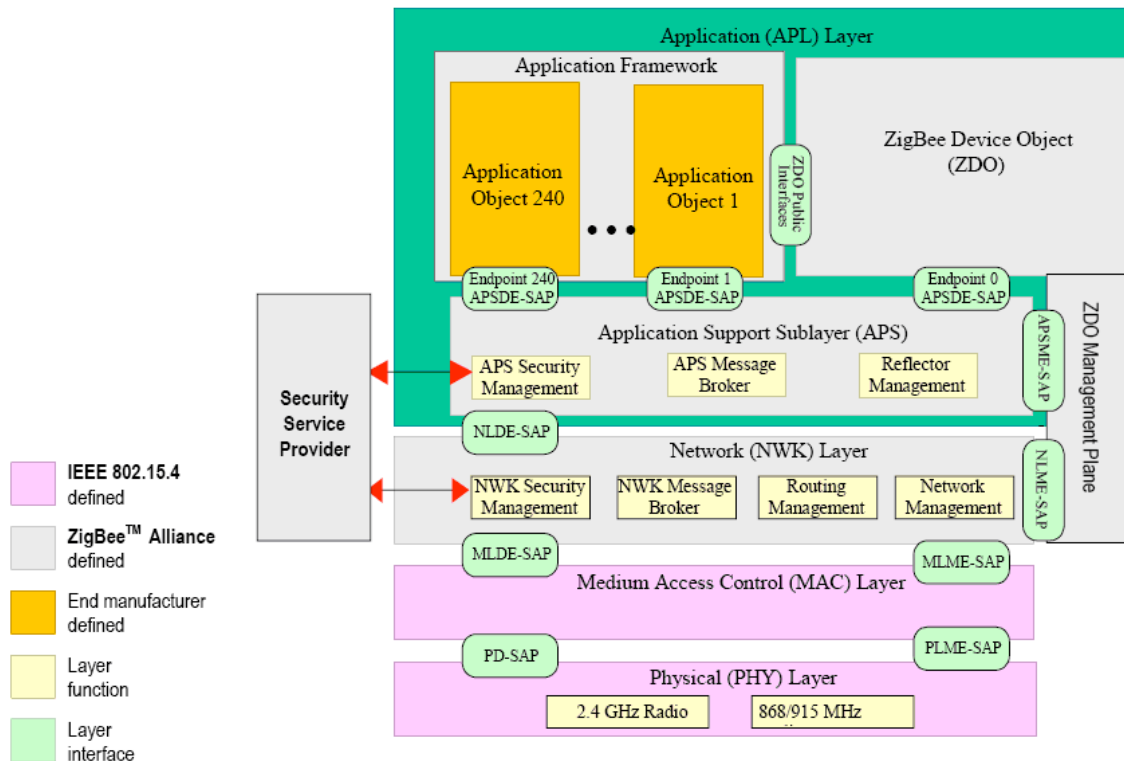

Figure 1 – Overview of ZigBee Layers [7]

2.2.1 Application Layer

Applications running on the ZigBee network are contained here. For example, applications to monitor temperature, humidity, or any other desirable atmospheric parameters can be placed on this layer for agricultural use. This is the layer that makes the device useful to the user. A single node can run more than one application. Applications are referenced with a number ranging from 1-240. Meaning there is a maximum of 240 applications on a ZigBee device. Application number 0 is reserved for a unique application that exists on all ZigBee devices. Another application number, 255, is also reserved. This number is used to broadcast a message to all applications on a node.

2.2.1.1 ZigBee Device Object (ZDO)

A special application is on every ZigBee device, and this is the ZigBee Device Object, or ZDO. This application provides key functions such as defining the type of ZigBee device (end device, router, and coordinator) a particular node is, initializing the network, and to also participate in forming a network.

2.2.2 Network Layer

A feature of ZigBee such as the self-healing mechanism is acquired through this layer. As Figure 1 shows, this layer provides network management, routing management, network message broker, and network security management. This layer is defined by the ZigBee Alliance, which is an association of companies united to work for a better ZigBee standard.

2.2.3 Security Plane

The security plane spans across both the network layer and the application layer. It is here, that security measures such as AES-based encryption is implemented. Another security feature is message timeouts, which adds a frame counter on to each frame. Using this frame counter, the device can determine the age of the message it receives, and detect the possibility that an old message was recorded and is played back to the device (replay attack).

2.2.4 Medium Access Control Sub-Layer

This layer extracted from the IEEE 802.15.4 standard provides services to the network layer above, which is part of the ZigBee stack level. The MAC layer is responsible for the addressing of data to determine either where the frame is going, or coming from. It is also this layer that provides multiple access control such as CSMA/CA allowing for reliable transfer of data. Beaconing is another feature implemented through this layer. Finally, the MAC sub-layer can be exploited by higher layers to achieve secure communication (by measures such as an ACL).

2.2.5 Physical Layer

The physical layer is provided by the IEEE 802.15.4 standard. This standard manages the physical transmission of radio waves in different unlicensed frequency bands around the world to provide communication between devices within a WPAN. The bands are specified in the table below, pairing it with the area that the band is used in.

Frequency Range (MHz)	Numbers of Channels Available	Region used
868-868.6	1	Europe
902-928	10	North America
2400-2483.5	16	Worldwide

Table 2: Frequency Bands used in 802.15.4[1]

This layer allows for channel selection to avoid radio interference, as well as data exchange with the layer above (MAC sub-layer) to provide it with service.

2.3 Network Topologies

ZigBee networks can contain a mixture of three potential components. These components are a ZigBee coordinator, a ZigBee router, and a ZigBee end device. Different types of nodes will have different roles within the network layer, but all various types can have the same applications.

ZigBee coordinator – For every ZigBee network, there can be only one coordinator. This node is responsible for initializing the network, selecting the appropriate channel, and permitting other devices to connect to its network. It can also be responsible for routing traffic in a ZigBee network. In a star topology, the coordinator is at the center of the star, and all traffic from any end device must travel to this node. It is still possible for end devices to talk to another end device, but the message must be routed through the coordinator. In a tree topology, the coordinator is at the top of the tree, and in a mesh network, it is the root node of the mesh. A ZigBee coordinator can also take part in providing security services.

ZigBee Router – A router is able to pass on messages in a network, and is also able to have child nodes connect to it, whether it be another router, or an end device. Router functions are only used in a tree or mesh topology, because in a star topology, all traffic is routed through the center node, which is the coordinator. Routers can take place of end devices, but the routing functions would be useless in such cases. If the network supports beaconing, then a router can sleep when inactive, periodically waking up to notify the network of its presence.

ZigBee End Device – The power saving features of a ZigBee network can be mainly credited to the end devices. Because these nodes are not used for routing traffic, they can be sleeping for the majority of the time, expanding battery life of such devices. These nodes carry just enough function to talk to parent nodes, which can be either a router or a coordinator. An end device does not have the ability to have other nodes connect to its network through the end device, as it must be connected to the network through either a router, or directly to the coordinator.

In the following sections, we go into detail about the three different types of topology possible for a ZigBee network. The legend to all topology figures are shown below, and each type of device is given a color code for easy viewing.

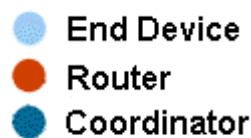

Figure 2 - Legend for ZigBee Devices

2.3.1 Star Topology

In this simple topology, a coordinator is surrounded by a group of either end devices or routers. Even though routers are connected to the coordinator, their message relaying functions are not used. This type of topology is attractive because of its simplicity, but at the same time presents some key disadvantages. In the event that the coordinator stops functioning, the entire network is functionless because all traffic must travel through the center of the star. For the same reason, the coordinator could easily be a bottleneck to traffic within the network, especially since a ZigBee network can have more than 60000 nodes.

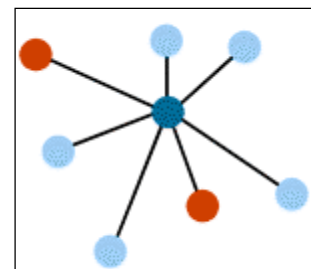

Figure 3 – Star Topology [6]

2.3.2 Tree Topology

In a tree network, a coordinator initializes the network, and is the top (root) of the tree. The coordinator can now have either routers or end devices connected to it. For every router connected, more child nodes can connect to the router. Child nodes cannot connect to an end device because it does not have the ability to relay messages. This topology allows for different levels of nodes, with the coordinator being at the highest level. For messages to be passed to other nodes in the same network, the source node must pass the message to its parent, which

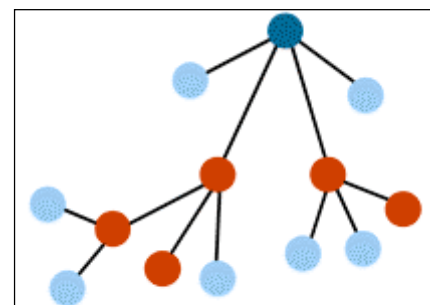

Figure 4 – Tree Topology [6]

is the node higher up by one level of the source node, and the message is continually relayed higher up in the tree until it can be passed back down to the destination node. Because the number of potential paths a message can take is only one, this type of topology is not the most reliable topology. If a router fails, then all of that router's children are cut off from communicating with the rest of the network.

2.3.3 Mesh Topology

A mesh topology is the most flexible topology of the three. Flexibility is present because a message can take multiple paths from source to destination. If a particular router fails, then ZigBee's self healing mechanism (aka route discovery) will allow the network to search for an alternate path for the message to take. In our project, one of the scenarios is to investigate this feature by removing a router from the network during operation, and seeing the end devices find an alternate path to communicate with the coordinator.

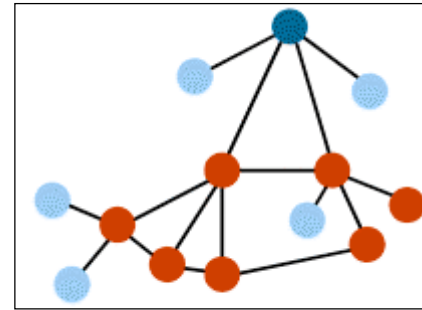

Figure 5 – Mesh Topology [6]

3 ZigBee Simulation Using OPNET

The ZigBee library for OPNET is new to OPNET v14.0. Unfortunately, the ZigBee model is incomplete and lacks some functions of ZigBee (will be discussed in the Discussions and Conclusion section).

ZigBee performs route discovery to determine the optimal path for messages to take to its destination. This section will discuss the results of various cases simulated on OPNET; Steady case with single router, router failure leading to self-healing, stability in the presence of moving end devices, case of variable bit rate transmitted, and some limitations observed possibly due to an incomplete ZigBee library model.

3.1 Traffic with Single Router

This scenario is a general and simple case to observe the behaviour of a ZigBee network in OPNET. Here, we have a coordinator on the far right, with a single router in the middle (router in the figure that's circled, has a small red cross in the middle signifying that the router is disabled, leaving ROUTER_1 the only functional router in the scenario), and a pair of end devices. The end devices will be sending data with a constant bit rate to the coordinator by first sending to the router, and then allowing the router to relay the message to the destination.

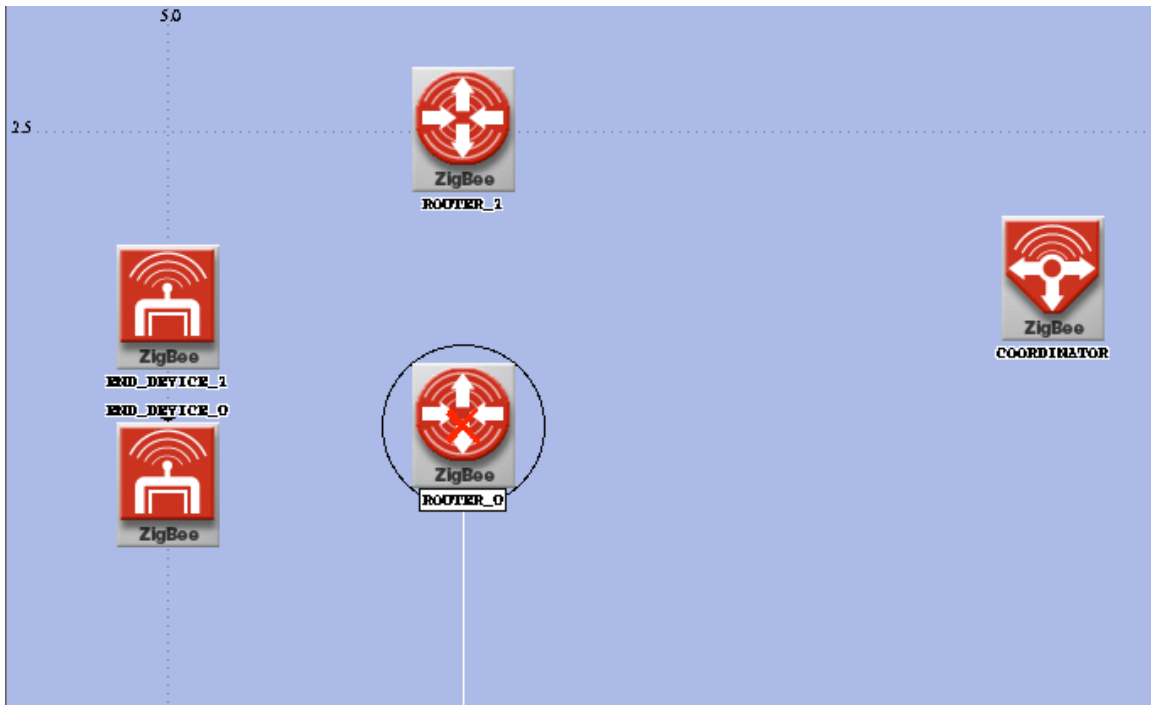

Figure 6 - Single Router Available Scenario

Figure 7 below shows the traffic being sent by the two end devices and received by the destination coordinator. The bottom red line (overlapping with green) is the traffic being sent by the end devices, where the blue line shows the traffic being received by the destination coordinator. It can be seen that steady stream of traffic is sent without disruption. Small spikes in at the beginning of the simulation are indications of management and control traffic sent and received to determine the presence of devices as well as the optimal route.

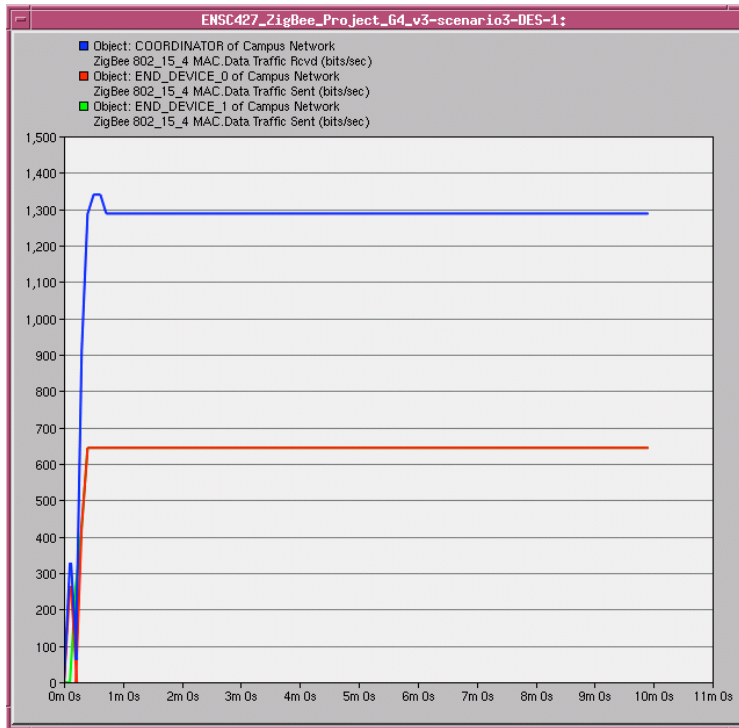

Figure 7 – Traffic from end devices to destination coordinator

Figure 8 (below) shows the traffic being received and sent (routed) by the two routers. The disabled router does not receive or send any traffic as expected. The amount of traffic being routed is equivalent to the traffic received by the coordinator as seen in the previous figure.

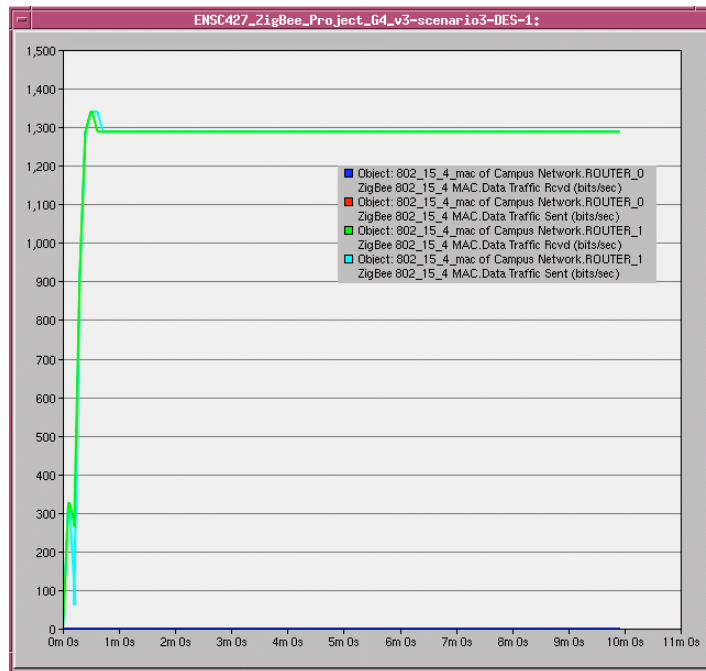

Figure 8 – Traffic sent and received by the two routers

Next two figures show the end-to-end (ETE) delay of traffic from the end devices. The average delay shows consistency in the amount of ETE delay. It shows that END_DEVICE_0 (blue line) initially connects with the router, showing much less delay compared to END_DEVICE_1 (red line) as it is using up the channel resource. It is worth noting the average ETE delay is 0.016s to 0.017s.

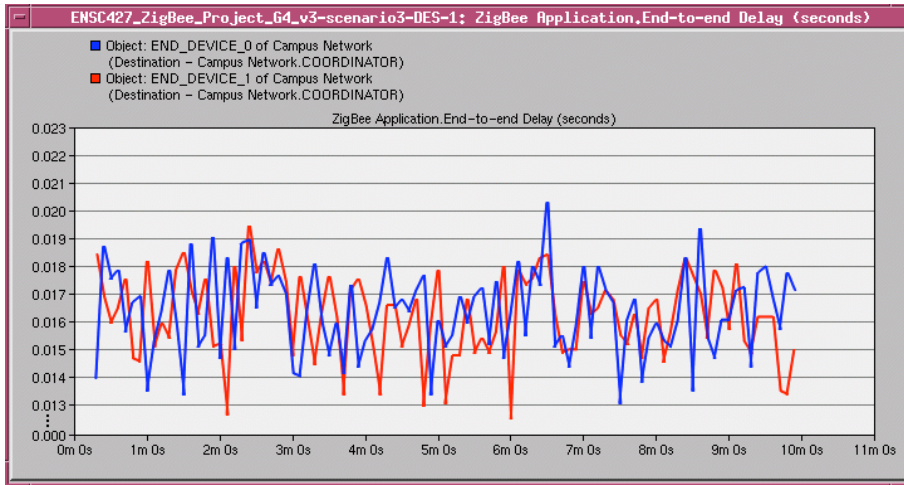

Figure 9 - End to End delay from end devices to coordinator (As Is)

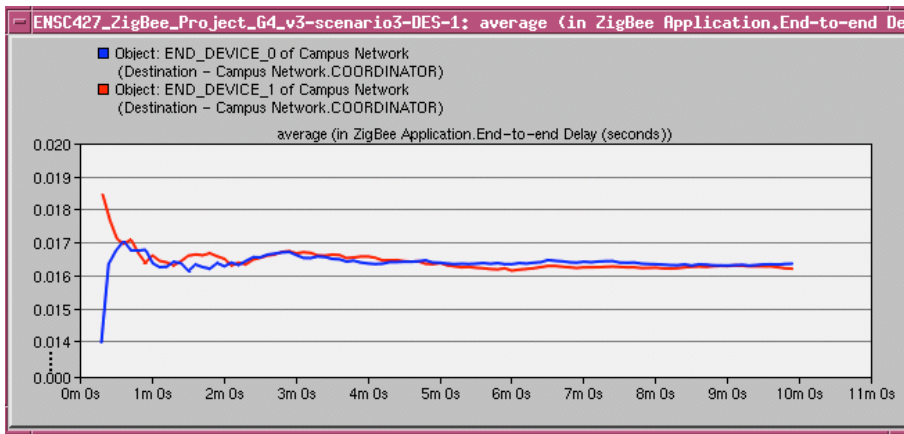

Figure 10 – End to End delay from end devices to coordinator (Average)

The results from this general scenario serve as a good starting point for comparison for the following scenarios where slightly more interesting cases will be observed. Also, it will help understand the variation in the results in the preceding scenarios.

3.2 Verification of ZigBee's Self-Healing Mechanism upon Router Failure

One method of simulating a failure in the router is to modify the code to add in a failure condition. However, this was deemed to be beyond scope of this project¹ and an alternative method was used.

The alternate method was to provide a trajectory to the router to move it out of range to trigger self-healing. This can be analogous to a case of router being blown away in the agricultural application due to extreme winds.

Two key features required for this case scenarios are the ACK enable and understanding the range capability of ZigBee. Placing the end devices too close to the destination coordinator will result in traffic being sent directly, rather than through the router, preventing observations for the self-healing feature. Also the ACK enable was required for the end devices to recognize that the failure in the router has occurred, no longer receiving and routing traffic, in order to trigger route discovery.

Figure 11 below illustrates the traffic path from end devices to the coordinator prior to the failure, where Figure 12 illustrates the traffic path after the failure in the bottom router, triggering the self-healing to find an alternate path to the destination.

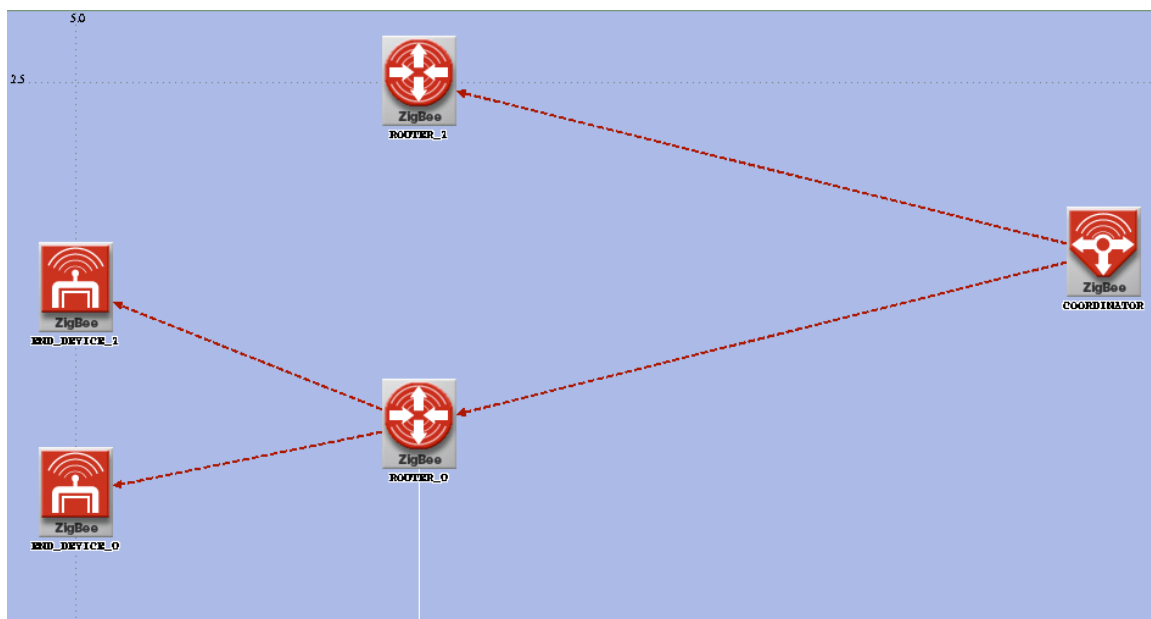

Figure 11 – Traffic path prior router failure

¹ OPNET did not disclose all the information for given library. Only the MAC layer Function Block and Header Block were provided (as well as packet formats and generic dra_power model). Rest of the code/implementation was hidden from view possibly due to work in progress.

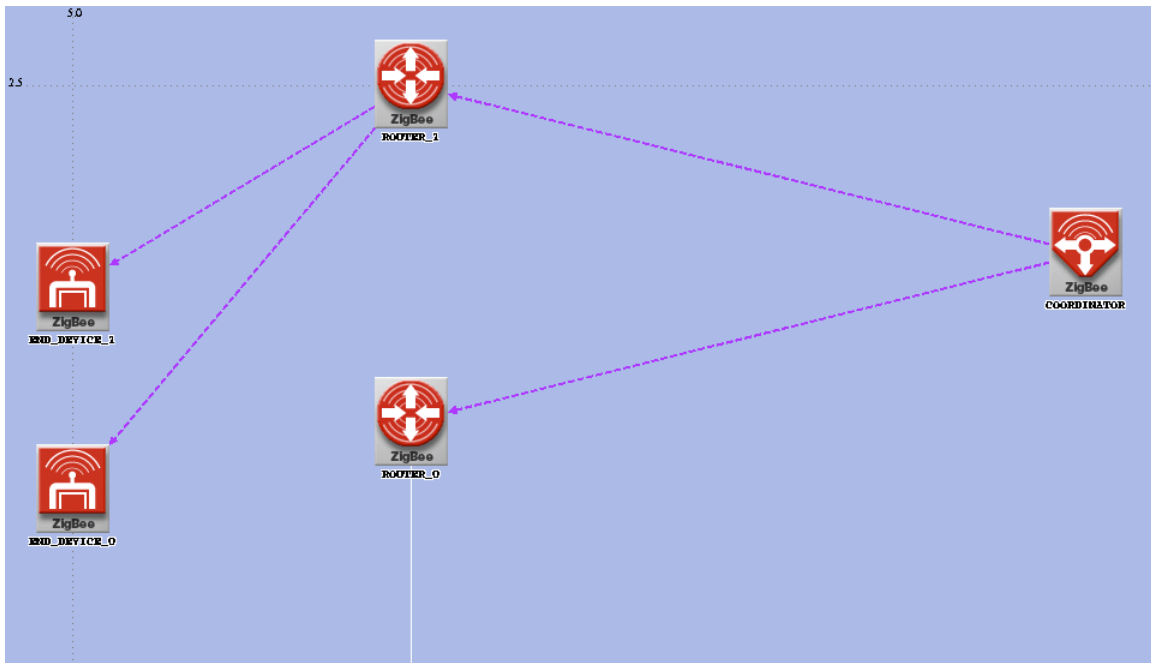

Figure 12 - Traffic path after router failure

Figures 13 to 17 below shows the statistics collected to observe the behaviour of self-healing. The failure in the router occurs at the five minute mark of simulated time. Figure 13 shows the traffic sent by the two end devices (blue line overlapping with red) and traffic received by the two routers. The green line shows a sharp drop at five minutes due to it being moved out of range of the end devices and stops receiving traffic. The light blue line along the top is the stationary router. It shows that router is receiving traffic from all neighbouring devices initially. This is due to the lack of a beaconing feature of ZigBee in this model, where non-active devices are able to go into sleep mode, occasionally waking up to notify its presence to the network. Despite the heavy traffic received by the stationary router, it does not transmit (route the traffic) to the destination coordinator as it will be described in the figure 14 and 15.

The sharp spike near the five minute time is similar to the spike observed near the start of simulation. This is in part due to the management and control traffic transmitted by the devices to perform route discovery. The spike at the five minute is caused by the self-healing feature of ZigBee, it simply recognizes absence of the original path and performs route discovery once again to find the next optimal path to its destination.

It can be seen that stationary router picks up the end device traffic and continues to route the traffic to the destination.

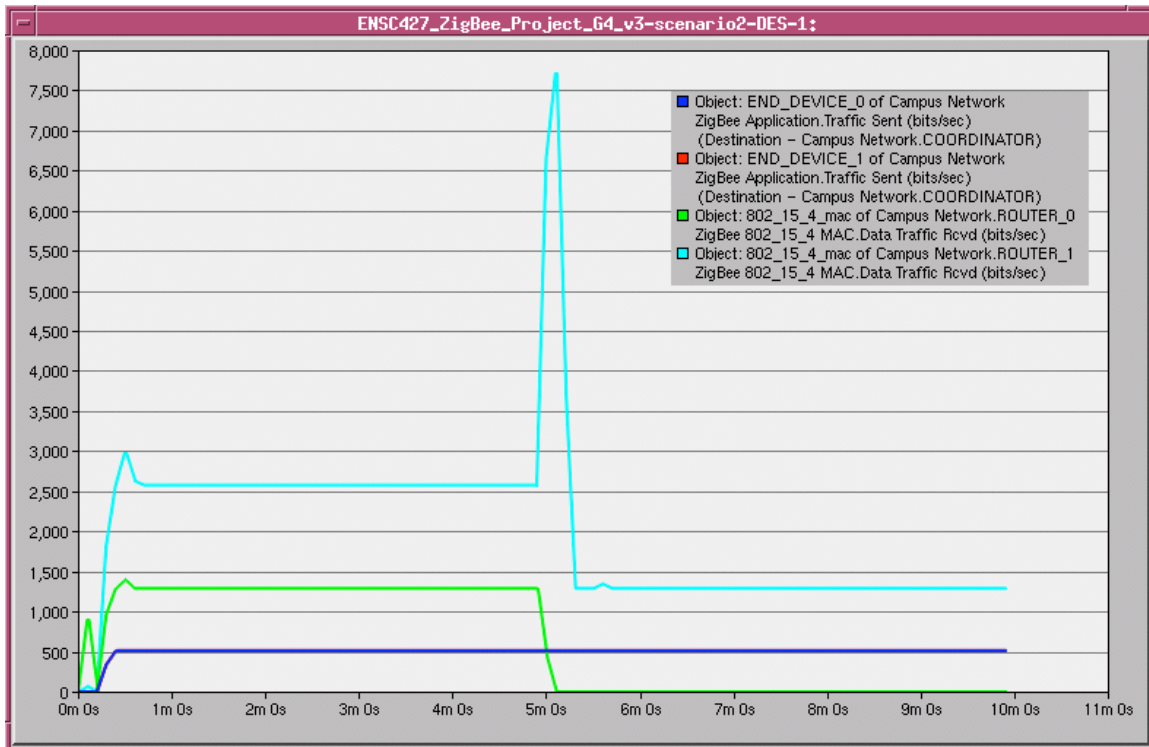

Figure 13 – Traffic Sent by end devices and received by routers

Figures 14 and 15 show the traffic between the two routers and the coordinator (destination). The blue line shows the traffic received by the coordinator while the red and green shows the traffic sent by the routers (to the coordinator). In the first five minutes, it can be seen that stationary router does not send (route) any traffic despite receiving large amounts (seen in figure 8 light blue line).

The coordinator continuously receives the traffic with one instance of a gap at the five minute simulated time. This is when the self-healing route discovery occurs. The mobile router attempts to find its place in the network (red spike). Once the initial router fails, the stationary router picks up the traffic and routes it to the destination.

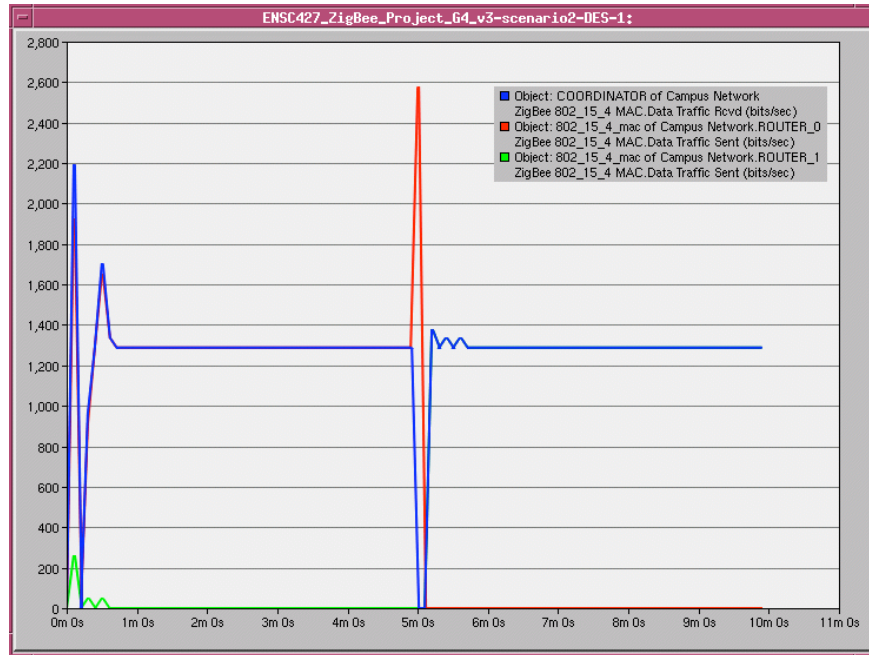

Figure 14 – Traffic from routers to coordinator (overlaid view)

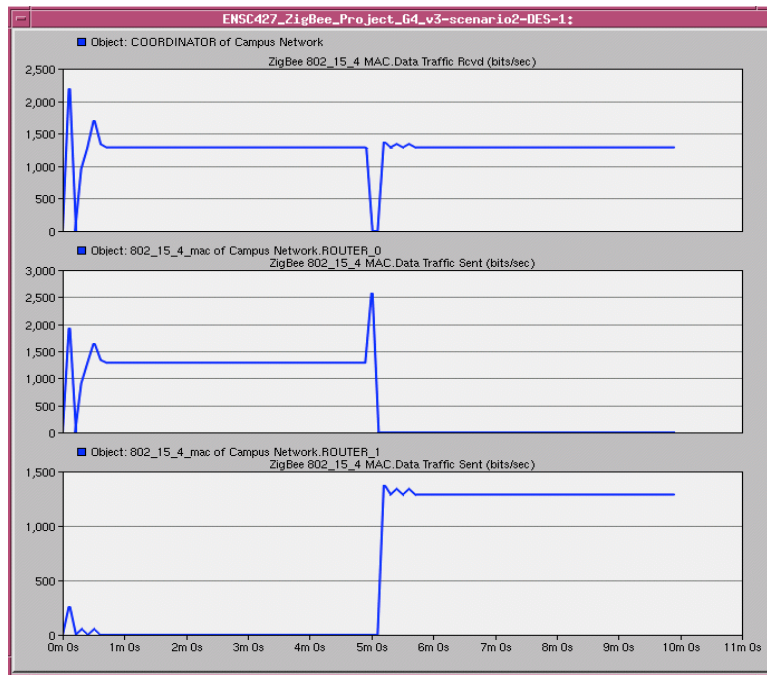

Figure 15 – Traffic from routers to coordinator (stacked view)

Figures 16 and 17 shows the end-to-end (ETE) delay seen from the end devices to the coordinator. This is a measure of time from generating the application packet to the time received by the destination. Figure 16 shows the “as is” ETE where the small gap at the five minute simulated time shows packets dropped while the router failure occurred. However, the average ETE delay is constant throughout as seen in Figure 17 demonstrating the consistency maintained in network traffic despite a router failure.

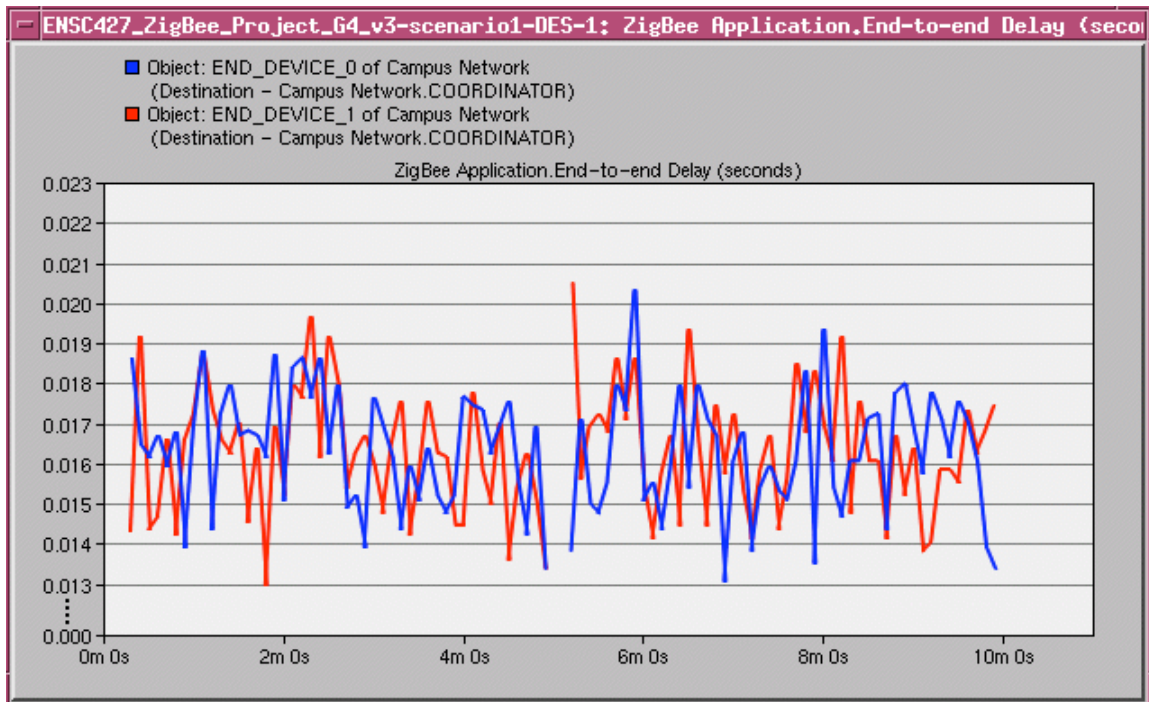

Figure 16 – End to End delay from end devices to coordinator (As Is)

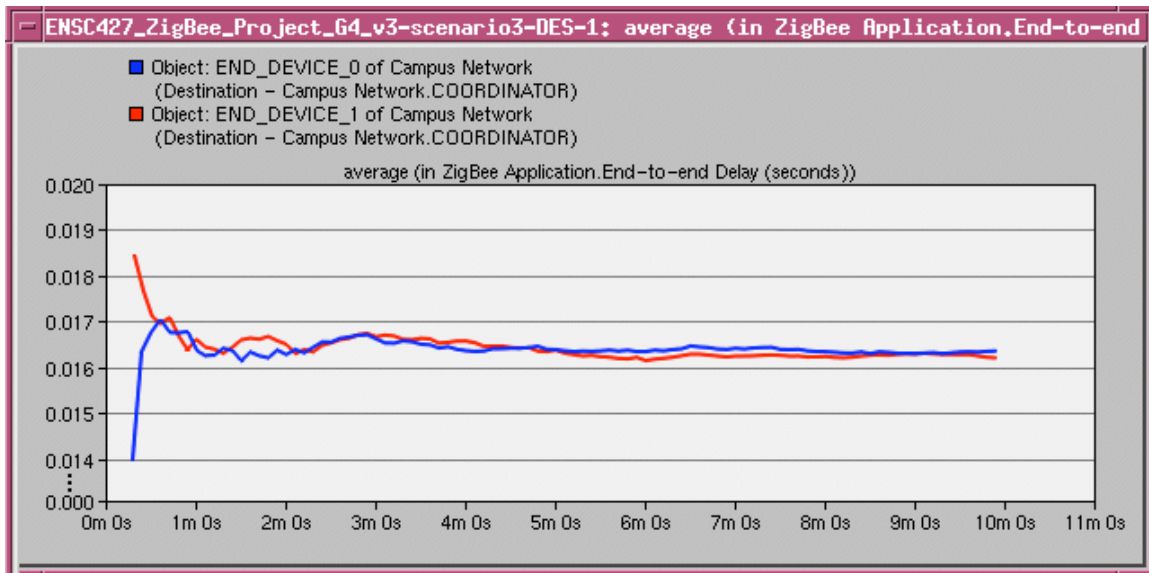

Figure 17 – End to End delay from end devices to coordinator (Average)

The results indicate that the overall performance of ZigBee's self-healing does quite well. The traffic generated from end devices were successfully received by the destination coordinator aside from small gap of simulated time window showing packets dropped. Also, the average ETE delay is very similar to that of simple single router scenario from before.

3.3 Traffic Stability in Presence of Moving End-Devices – CBR

Because ZigBee networks can be used as a sensor network in such environments as hospitals, and agricultural (livestock) environments, it is important for ZigBee to perform well even when end devices are not stationary. In this scenario, we set an end device on a path that travels in different directions in range of ~300 to ~3000 meters. In theory, the fact that the end device is moving should not make a difference in the amount of traffic that the router successfully receives even if it leaves the PAN momentarily and then comes back in range. Below is a figure showing how the simulation was configured including the trajectory path for the mobile end device.

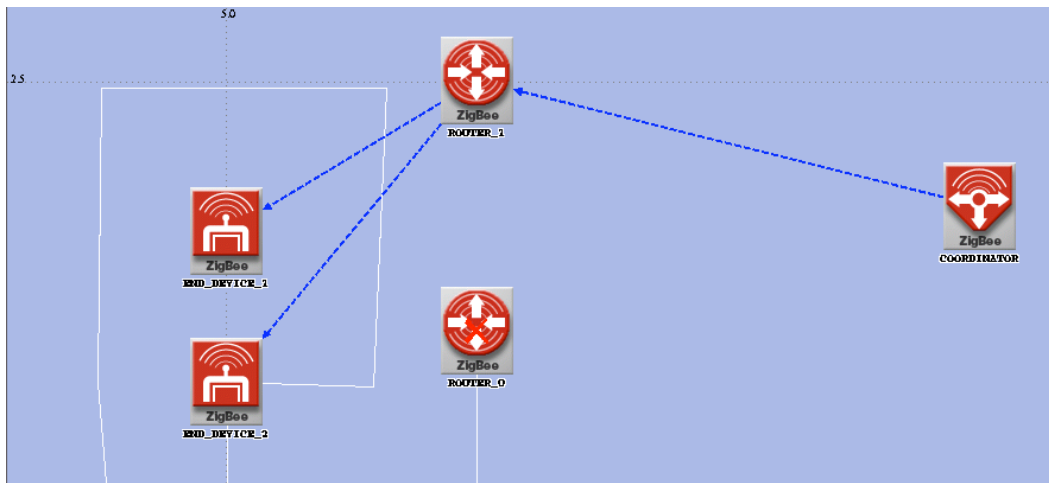

Figure 18 - Traffic and Trajectory Path

The mobile end device moves around the network in a counter-clock wise motion within the network. After 4 minutes and 22 seconds the mobile node moves out of range temporarily, and then it re-enters the network.

The two figures below show the traffic received by the coordinator, and the traffic sent by the router and end devices.

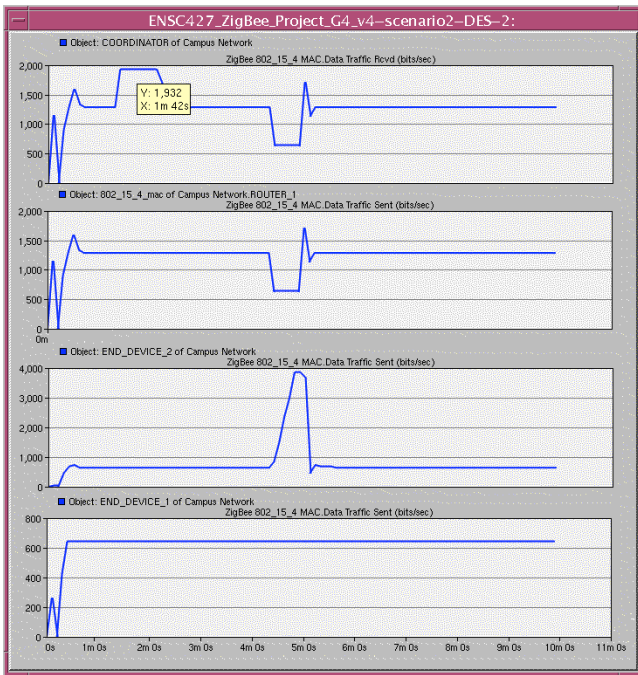

Figure 19 - Traffic Sent From End Devices & Routers to Coordinator

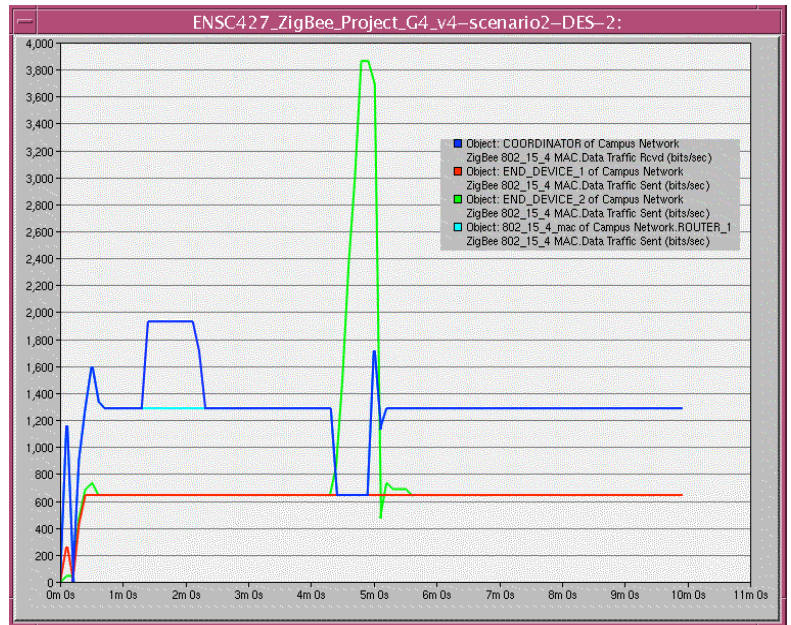

Figure 20 - Traffic Sent From End Devices & Routers to Coordinator

Looking at the graphs above we take note on some interesting things. At about 1m30s the coordinator traffic increases by 644 bits/second because the mobile node comes in range and sends traffic to both the router and coordinator. Next at 4:22 the router and coordinator data rates decrease by 644 bits/second because End_Device_2 is out of range. Then at about 5:04 End_Device_2 comes back in range increasing the router and coordinator traffic by 644 bits/second. Below in figure 21 the end to end traffic is shown for each of the end devices.

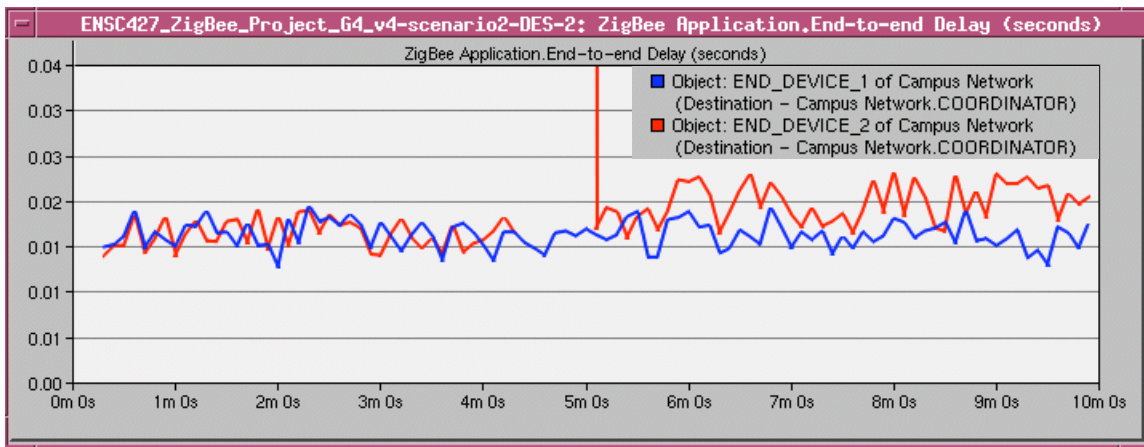

Figure 21 - End-to-end delay showing packet drop around 5minute simulated time (As Is)

Notice that between 4:22 – 5:04, the end to end delay is undefined for END_DEVICE_2 because the packets are being dropped when it's out of range. From these results we see that Zigbee's performance is not affected by having mobile devices. The network is able to release a device and let it re-enter the network without any slips.

3.4 Assessing Network Performance with Stationary End-Devices – VBR

In the event that the traffic being sent is not constant, it is important for the network to still be able to perceive all information being sent. In this scenario, we configure the end devices to send data at a variable bit rate (VBR) instead of a constant bit rate used in the other scenarios. The parameter to be compared is the end-to-end (ETE) delay, and we will compare this scenario's delay with our first scenario's delay, which is a simple 2 end device, 1 router, 1 coordinator network with constant bit rate transfer. The topology of the network can be seen in figure below.

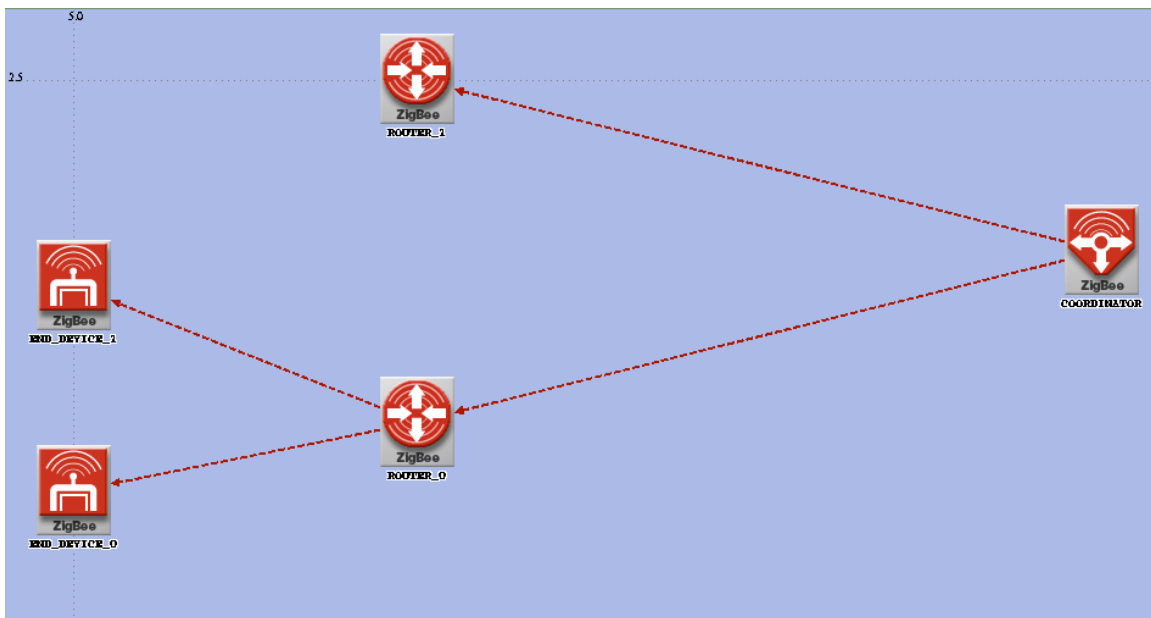

Figure 22 – Same layout as scenario 3.1 using variable packet rate

In the figure below, we see the average traffic being sent over the network. As expected, the traffic being sent by the pair of end devices is successfully received by the router, which is then successfully forwarded to the coordinator. The discrepancy in the beginning of the graph between the router (light blue) and the coordinator (blue) can be accounted for by the second router (yellow), which was left on, but had no end devices attached to it. The initial spike of data is due to the network setup (route discovery). The second router (yellow) flat lines because no data is being relayed by the router, and the router itself is not sending any data either.

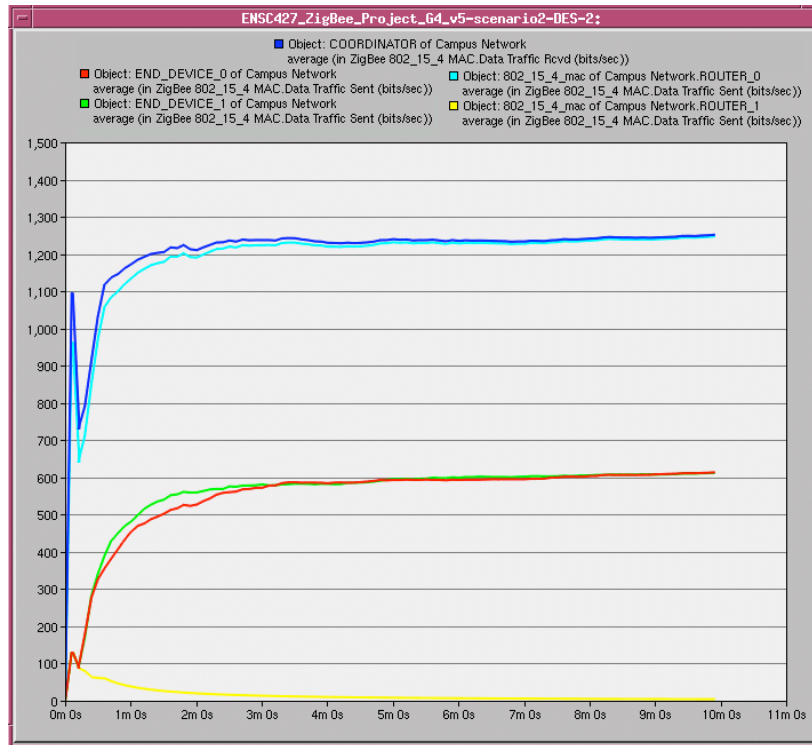

Figure 23 – Traffic sent by end devices to destination coordinator with route traffic

The graph below shows that the data being sent from the end devices are indeed not a constant rate, but a variable bit rate. The data received by the coordinator (blue) the addition of the data being sent by the two end devices (red and green). For this simulation, we decided to send data with variable packet sizes varying from 500 -1524 bytes, at a constant packet rate of 1 packet for every 2 seconds.

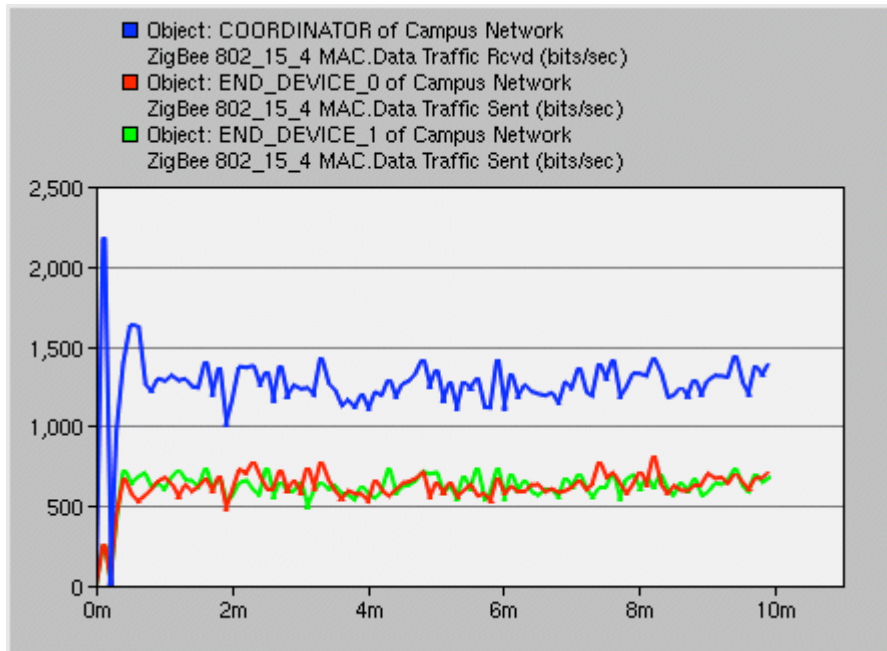

Figure 24 – Traffic Sent From End Devices to Coordinator

Even though the above screenshots prove the success of packets arriving at their destination, it is important that the data arrives promptly, or else the data could be useless by the time it arrives at the destination. For this reason, we must check the end-to-end delay of the packets being sent. Below, are two graphs, that show an “as is” and average end-to-end delay. Because of the varying size of packets being sent, the delay is not a constant, and in figure x we see the varying delay, which can be accounted for by the packet sizes. On figure 25, we can see the average delay for the packets being sent. The initial spike can be attributed to the setup of the network. After approximately 3 minutes, we see the ETE delay calm to a steady state of approximately 16 milliseconds.

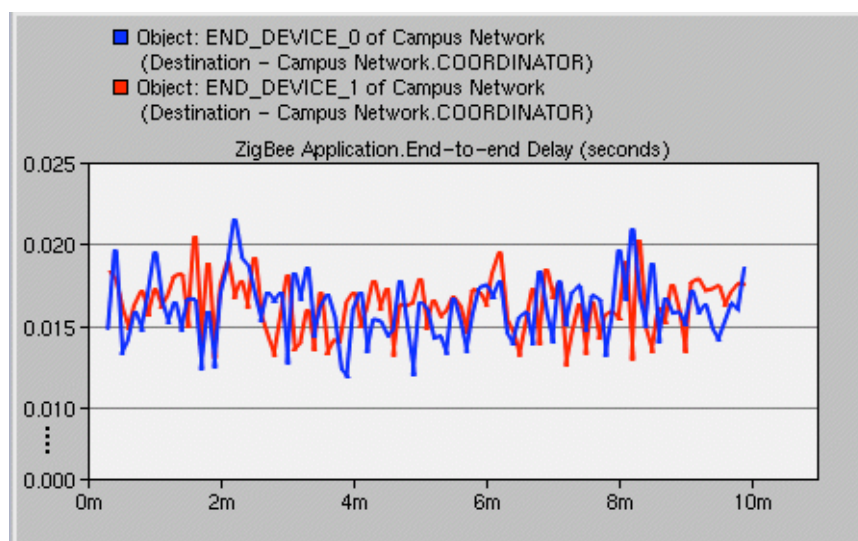

Figure 25 – End to End delay from End Devices to Coordinator (As Is)

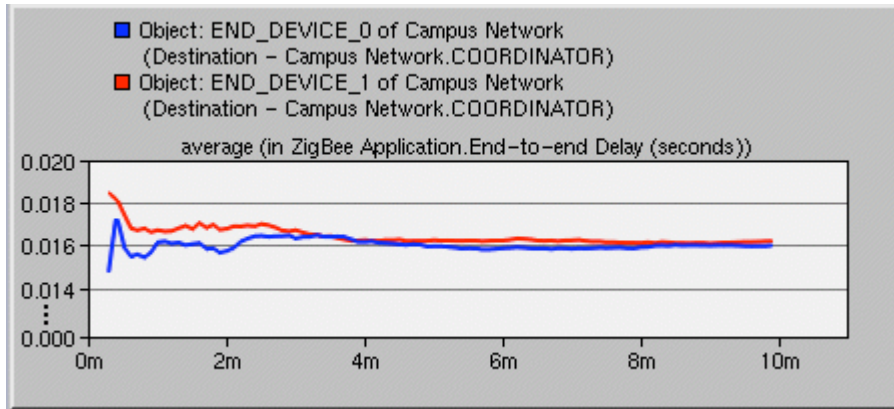

Figure 26 – End to End delay from End Devices to Coordinator (Time Average)

These results show that sending data with a VBR does not decrease the performance of a ZigBee network. The latency of the network is still steady even at the presence of varying packet sizes.

3.5 Testing the ZigBee OPNET Model Limits – Adding Additional End Devices

During our simulations of various scenarios, we noticed that the ZigBee model in OPNET has some limitations and unfinished features. One of these limitations is connecting only up to two end devices per router. We know from the ZigBee specifications that a ZigBee network can have more than 64000 nodes, so for this scenario, we simply tried to connect 3 end devices to a single router, and see if the router can handle the incoming traffic.

Figure 27 below shows the traffic path in the case of two routers with three end devices. All the end devices manage to connect to a router to send traffic to the destination coordinator.

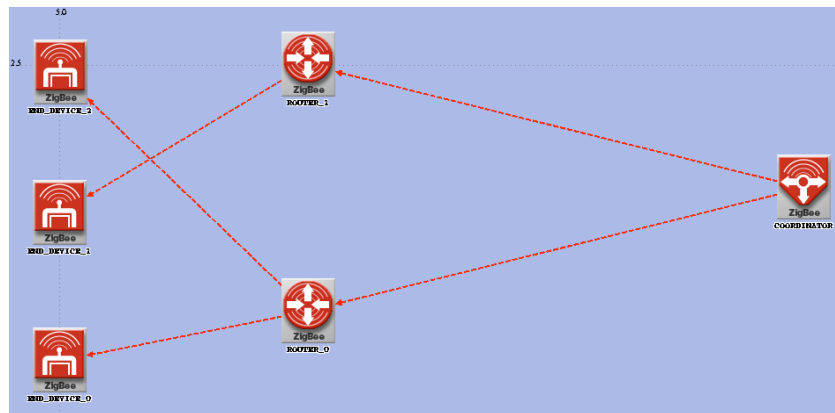

Figure 27 – Case of two routers and three end devices

The graph below shows the traffic being received by the coordinator (blue) and the traffic being sent by the three end devices (red overlaps with green and light blue). This graph indicates that the coordinator has sufficient bandwidth in the channel to receive the level of traffic coming from three end devices.

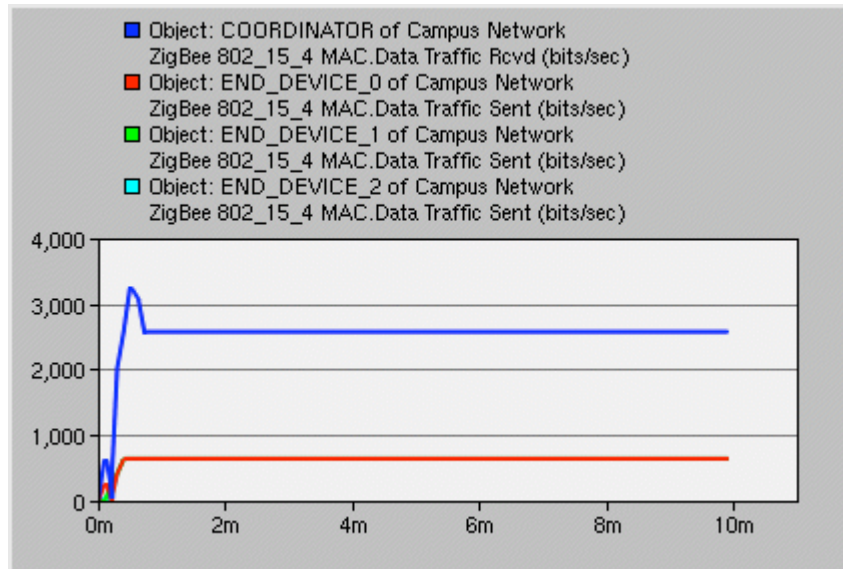

Figure 28 – Traffic sent by the end devices and received by the coordinator

Next figure shows the traffic path when the bottom router is disabled. It can be seen that END_DEVICE_1 (middle end device) fails to establish a traffic path to the router. This is a result of lacking the slotted CSMA/CA with beaconing feature along with Guaranteed Time Slot. Once two of the end devices connect to a router, it shares the connection (during intermitting traffic send times) but does not allow for the third end device to join. Also, the router is not capable of assigning the time-slot to schedule in the third end device.

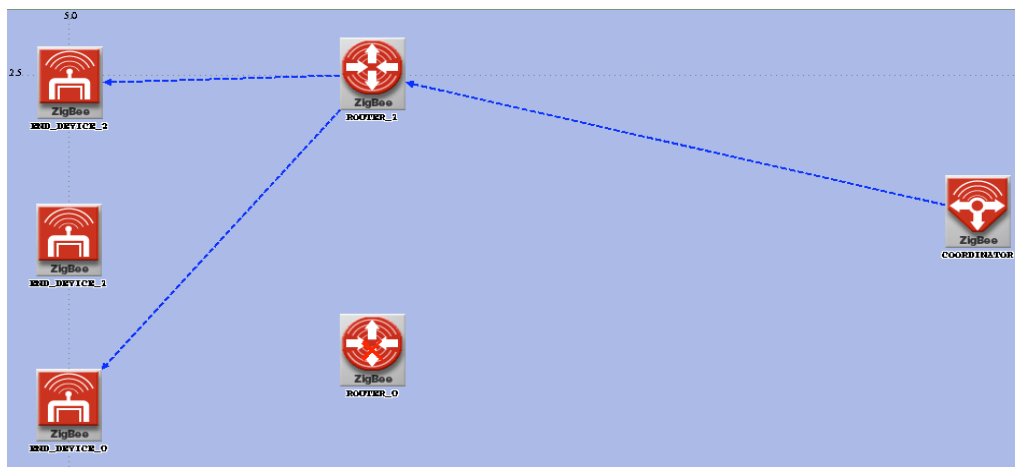

Figure 29 – Case of single router and three end devices

The result indicates that the end device in the middle (END_DEVICE_1) was unable to deliver any of the packets as they were all dropped en route (red line) while the other two end devices (blue overlap with green) experienced no dropped packets.

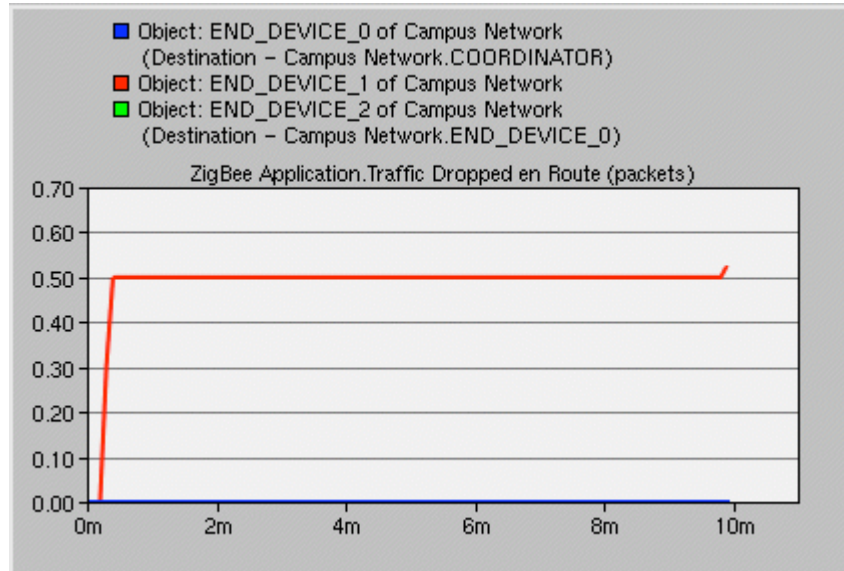

Figure 30 – Traffic from three end devices dropped en route

4 DISCUSSIONS AND CONCLUSION

4.1 OPNET ZigBee Model Limitations

Through this project, we have learned some of the limitations about the ZigBee model in OPNET. The most noticeable limitation of the ZigBee model is the incomplete implementation of the beaconing² capability (“Note: Beacon Enabled mode is not currently supported. This attribute is a placeholder”).

Also lacking, is support for slotted CSMA/CA mode and contention – free operation mode. This seemed to prevent the devices from having “fair” use of the resource by scheduling the end devices to gain access to the channel.

One of the difficulties at the early stages of this project was the lack of mention in the range capability of ZigBee. Since the OPNET ZigBee model was incomplete we expected an earlier version of ZigBee with specified range of ~100meters. However, the OPNET ZigBee model was capable of handling ranges beyond 1200meters at default settings for transmission power and reception power. This initially caused the end devices to skip over the routers and communicate directly with the coordinators (showing no variation in the results for 3.2).

4.2 What We Learned

Through this project we were given the opportunity to learn not just any protocol and OPNET but a technology of interest. Switching over to ZigBee from Bluetooth part way due to limited availability of a Bluetooth library from OPNET required some catching up, possibly limiting our opportunity to do a little more, but this provided us with an opportunity to learn a lot about ZigBee, a growing technology, in terms of general application and technical aspects. Through simplified scenarios with an assortment of variations, we were able to better understand the results in reasonable time compared to having complex scenarios and results, then having to spend a lot of the project time trying to make sense of things.

We also learned the various functionalities and models OPNET is capable of, despite the ZigBee model being only a small portion of OPNET, as well as some of the limitations in using OPNET. We experienced a bit of disappointment with the incomplete ZigBee model library and hidden implementation of layers (except the MAC layer).

² Beacon enabled network allows for much longer battery life by allowing the device to go to sleep periodically only to wake to notify the network of its presence when not in use

5 REFERENCES

- [1] IEEE Standard for Information technology- Telecommunications and information exchange between systems- Local and metropolitan area networks- Specific requirements Part 15.4: Wireless Medium Access Control (MAC) and Physical Layer (PHY) Specifications for Low-Rate Wireless Personal Area Networks (WPANs), IEEE Standard 802.15.4, 2006. [Online]. Available: <http://ieeexplore.ieee.org/stamp/stamp.jsp?arnumber=1700009&isnumber=35824>
- [2] N. Liang, P. Chen, T. Sun, G. Yang, L. Chen, and M. Gerla, "Impact of Node Heterogeneity in ZigBee Mesh Network Routing," in *IEEE Int. Conf. Systems, Man and Cybernetics*, vol. 1, Taipei, Taiwan, 2006, pp. 187-191. [Online]. Available: <http://ieeexplore.ieee.org/stamp/stamp.jsp?arnumber=4273827&isnumber=4273788>
- [3] J. Sun, Z. Wang, H. Wang, and X. Zhang, "Research on Routing Protocols Based on ZigBee Network," in *Thrid Int. Conf., Intelligent Information Hiding and Multimedia Signal Processing*, vol. 1, Kaohsiung, Taiwan, 2007, pp. 639-642. [Online]. Available: <http://ieeexplore.ieee.org/stamp/stamp.jsp?arnumber=4457629&isnumber=4457471>
- [4] X. Xu, D. Yuan, and J. Wan, "An Enhanced Routing Protocol for ZigBee/IEEE 802.15.4 Wireless Networks," in *Second Int. Conf., Future Generation Communication and Networking*, Hainan, China, 2008, pp. 294-298. [Online]. Available: <http://ieeexplore.ieee.org/stamp/stamp.jsp?arnumber=4734107&isnumber=4734039>
- [5] Digi International, "ZigBee Wireless Standard," Digi Making Wireless M2M Easy. [Online]. Available: <http://www.digi.com/technology/rf-articles/wireless-ZigBee.jsp>. [Accessed: 2009-02-28].
- [6] Jennic, "Welcome to Jennic's ZigBee e-learning Course," 2007. [Online]. Available: http://www.jennic.com/elearning/zigbee/files/content_frame.htm
- [7] Mesh-Matrix Inc., "What is ZigBee," 2007. [Online]. Available: http://mesh-matrix.com/en/technology/tech_zigbee.aspx
- [8] P. Jurčík, A. Koubâa, M. Alves, E. Tovar, and Z. Hanzálek3, "A Simulation Model for the IEEE 802.15.4 Protocol: Delay/Throughput Evaluation of the GTS Mechanism," [Online]. Available: <http://dce.felk.cvut.cz/hanzalek/publications/Hanzalek07g.pdf>