

ENSC 427: COMMUNICATION NETWORKS

Final Project Presentation

Comparison of EIGRP, RIP and OSPF Routing Protocols based on OPNET

http://www.sfu.ca/~sihengw/ENSC427_Group9/

Siheng Wu 301153928 (sihengw@sfu.ca)

Kenny Sun 301154475 (yujuns@sfu.ca)

Justin Deng 301138281 (zda9@sfu.ca)

Group 09

Roadmap



- Introduction
- Background
- Routing Protocols
- Implementation Details
- Discussion
- References

Introduction

Objective of the project:

- Introduce three different Routing Protocols
- Introduce the common Network Topologies
- Compare the performance of these three protocols using OPNET 16.0
- Conclude the best routing protocol in different topologies

Background

What is routing protocol?

- It is a set of standard that specifies how routers communicate and exchange information in networks. It enables the network to make the routing decision.

RIP (Routing Information Protocol)

- Distance Vector

RIP is a standardized vector distance routing protocol and uses a form of distance as hop count metric.

- Four Basic Timers

1. Update Timer
2. Invalid Timer
3. Hold-down Timer
4. Flush Timer

RIP (Routing Information Protocol)

- Update Timer:
It indicates how often the router will send out a routing table update.
- By default, it is 30 seconds.

RIP (Routing Information Protocol)

- Invalid Timer:

It indicates how long a route will remain in a routing table before being marked as invalid if no new updates are heard about this route. The invalid timer will be reset if an update is received for that particular route before the timer expires.

- By default, it is 180 seconds.

RIP (Routing Information Protocol)

- Hold-down Timer:

It indicates how long RIP will “suppress” a route that it has placed in a hold-down state. RIP will not accept any new updates for routes in a hold-down state, until the hold-down timer expires.

- By default, it is 180 seconds.

RIP (Routing Information Protocol)

- Flush Timer:

It indicates how long a route can remain in a routing table before being flushed if no new updates are heard about this route.

- By default, it is 240 seconds.

OSPF (Open Shortest Path First)

- Defined in RFC 2328
- Interior Gateway Protocol
- Distribute information within an Autonomous System
- Most widely used in large enterprise networks

OSPF (Open Shortest Path First)

- Use SPF (Shortest Path First) algorithm to choose the shortest path from one router to all the other routers
- Before calculating the shortest path, all routers must know about all the other routers in this network
- Exchange link-state for all the routers and stored in a link-state database

OSPF (Open Shortest Path First)

□ How OSPF works?

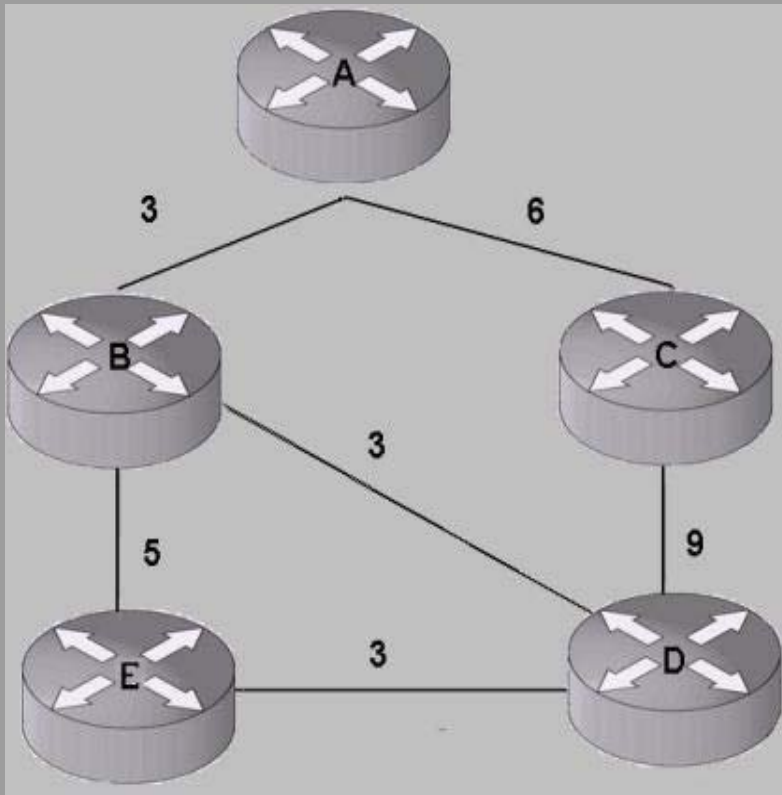

The link database for the above model is : [A, B, 3], [C, 6], [B, A, 3], [B, D, 3], [B, 5], [C, A, 6], [C, D, 9], [D, C, 9], [D, B, 3], [D, E, 3] , [E, B, and [E, D, 3].

OSPF (Open Shortest Path First)

- Dijkstra Shortest Path First calculates the shortest path based on the completed database
- Shortest Path Tree
- Put each router at the root of the tree to calculate the shortest path

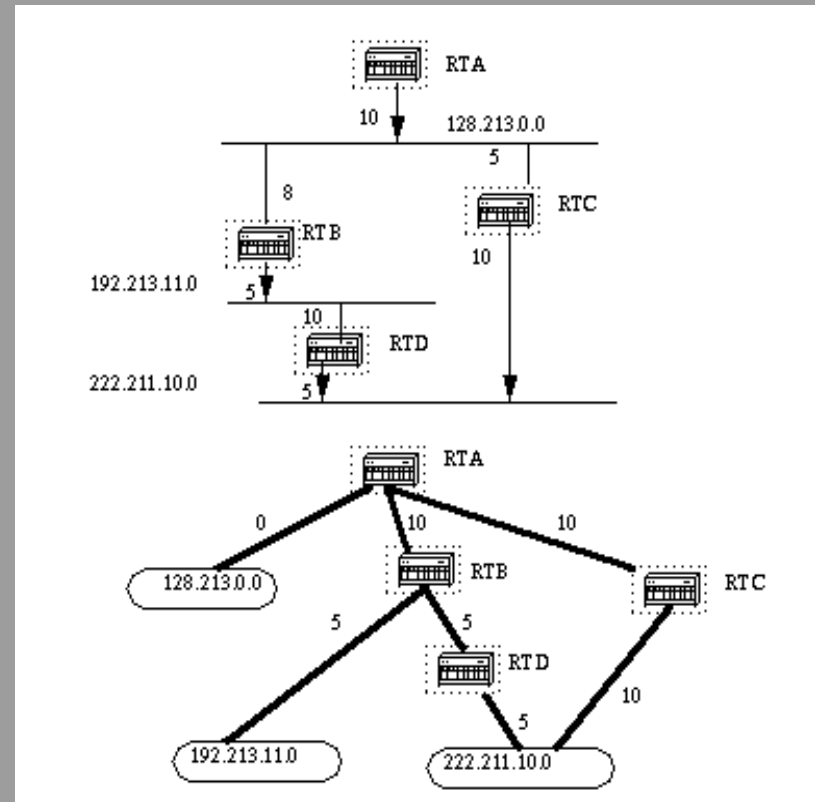

OSPF (Open Shortest Path First)

- The cost (metric): the cost of sending packets across a certain interface.

$$\text{cost} = 100000000 / \text{bandwidth in bps}$$

With wider bandwidth, the cost will be decreased

The accumulated cost to reach the destination is the Shortest Path Tree

OSPF (Open Shortest Path First)

- Areas: an Autonomous can be divided into sub-sections
- A section and nearby router form an AREA
- Each section has its own database and path tree
- Decrease size of database and enhance efficiency
- Backbone: Area 0, the pivot of an Area
- Must have to rely on area 0 to communicate inter-area.

EIGRP (Enhanced Interior Gateway Routing Protocol)

- ❑ Only available on Cisco routers before 2013
- ❑ Only shares information that a neighbouring router would not have, rather than sending all of its information
- ❑ It is optimized to help reduce the workload of the router and the amount of data that needs to be transmitted between routers.

EIGRP (Enhanced Interior Gateway Routing Protocol)

Four basic components in EIGRP:

1. Neighbour Discovery/Recovery
2. Reliable Transport Protocol
3. DUAL Finite State Machine
4. Protocol Dependent Modules

Neighbour Discovery/Recovery

- It is used to dynamically learn of other routers on their directly attached networks.
- Routers must also discover when their neighbours become unreachable or inoperative.
- It is achieved with low overhead by periodically sending small hello packets.
- As long as hello packets are received, a router can determine that a neighbour is alive and functioning. Once this is determined, the neighbouring routers can exchange routing information.

Reliable Transport Protocol

- It is responsible for guaranteed, ordered delivery of EIGRP packets to all neighbours. It supports intermixed transmission of multicast or unicast packets.
- EIGRP sends a single multicast hello with an indication in the packet informing the receivers that the packet need not be acknowledged.
- The reliable transport has a provision to send multicast packets quickly when there are unacknowledged packets pending. This helps insure that convergence time remains low in the presence of varying speed links.

DUAL Finite State Machine

- It embodies the decision process for all route computations. It tracks all routes advertised by all neighbours.
- Metric is used by DUAL to select efficient loop free paths.

Protocol Dependent Modules

- It is responsible for network layer, protocol-specific requirements.
- For example, the IP-EIGRP module is responsible for sending and receiving EIGRP packets that are encapsulated in IP.

Differences

	RIP	OSPF	EIGRP
Protocol Type	Distance Vector	Link State	Hybrid
Algorithm	RMTI	SPF	DUAL
Convergence	slow	fast	very fast
Update	30 seconds	Trigger	Partial update
Standard-Based	RFC	RFC	Cisco
Default Metric	Hops Count	Bandwidth	Bandwidth/Delay
HopCount Limit	15	No limit	255

Convergence (small network)

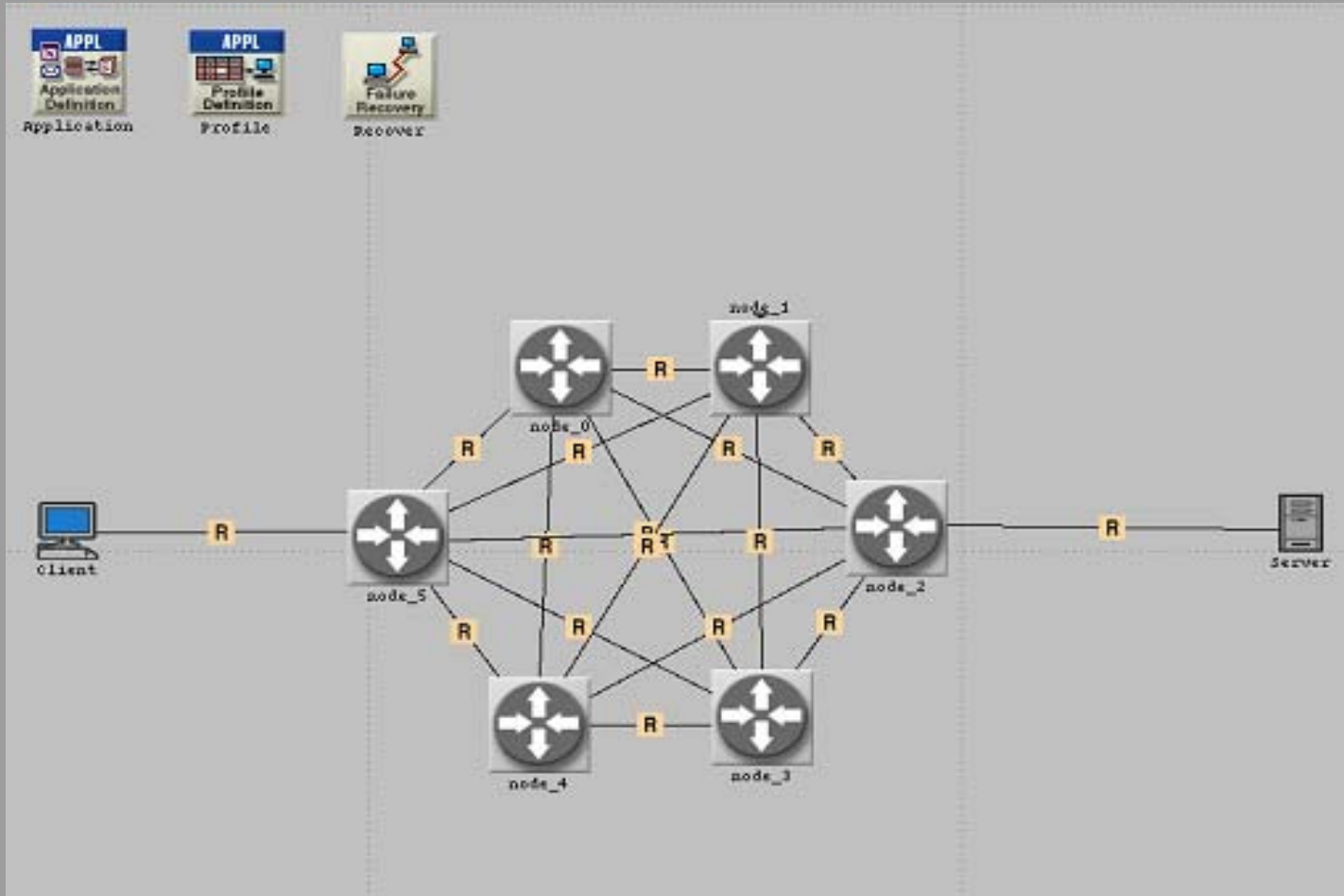

Convergence (small network)

- Speed: EIGRP > RIP > OSPF
- OSPF needs preset
- OSPF has larger convergence time than both EIGRP and RIP in small network

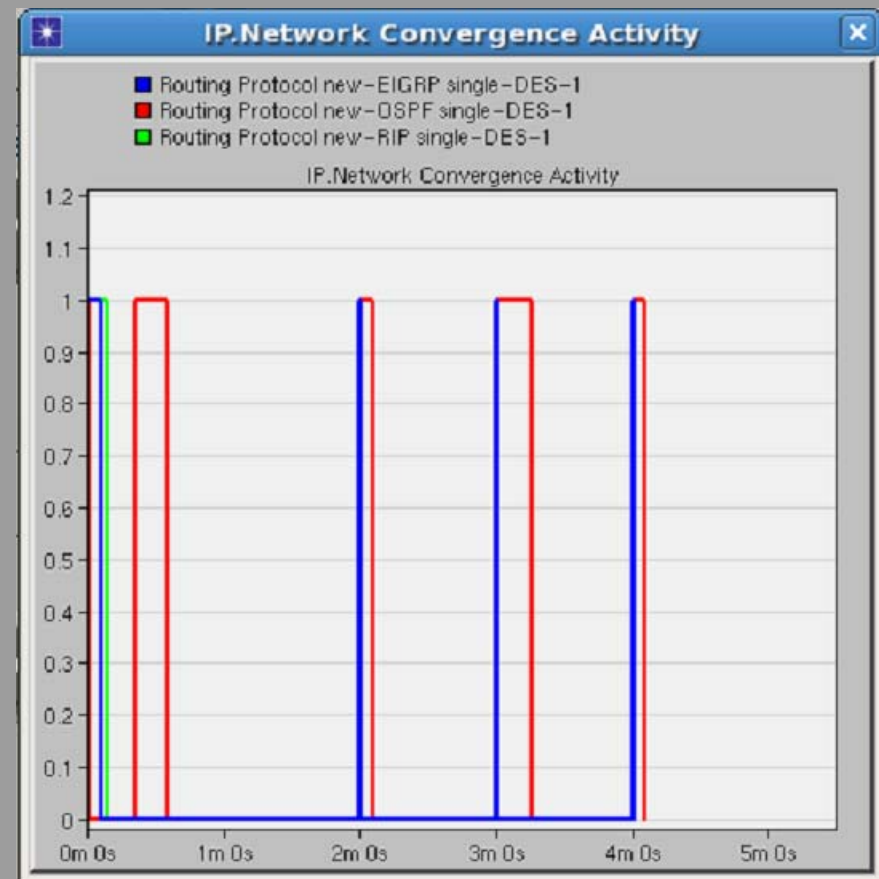

Convergence (large mesh)

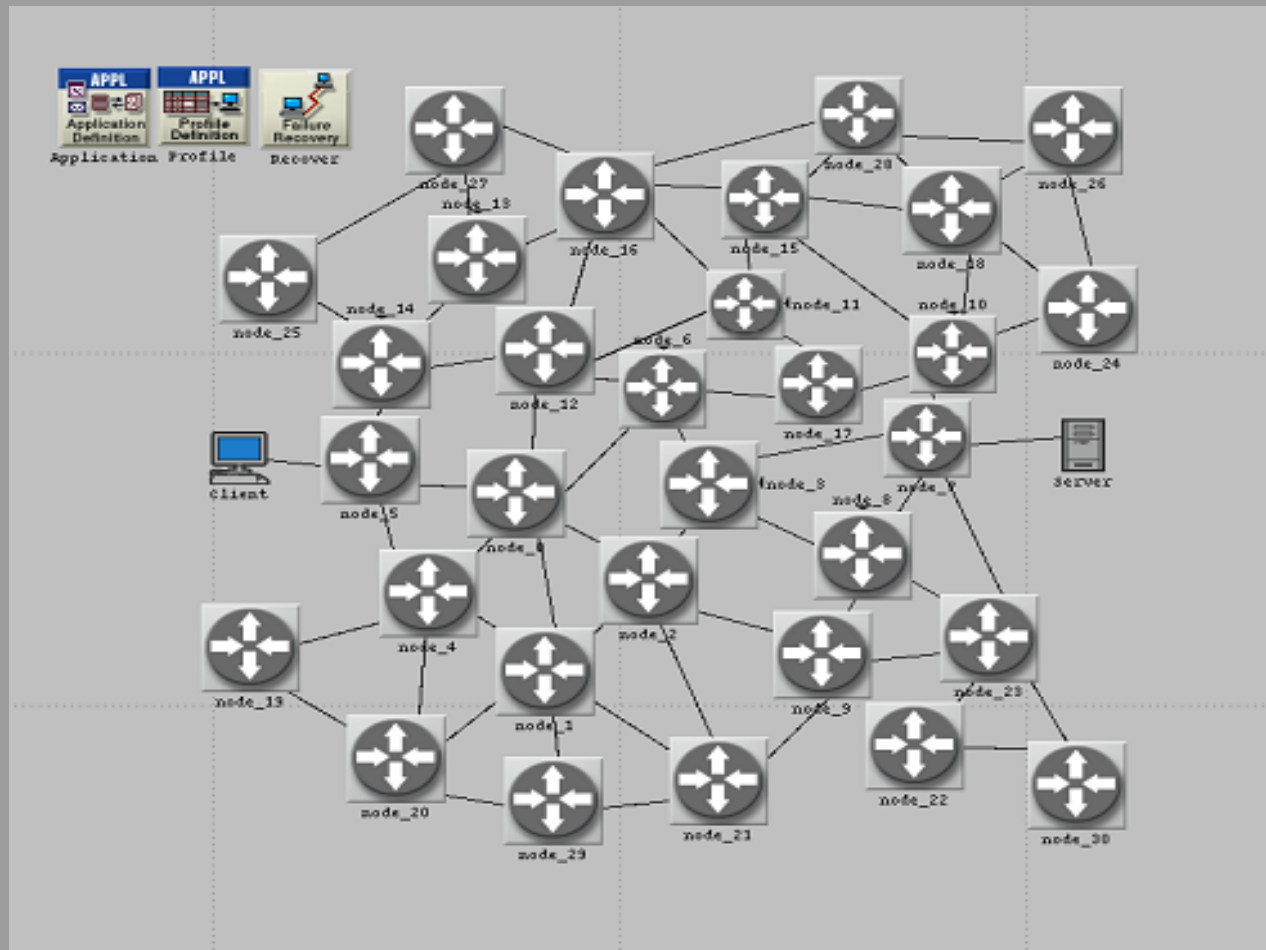

Convergence (large mesh)

- Speed: EIGRP > OSPF > RIP
- RIP is limited by hop count

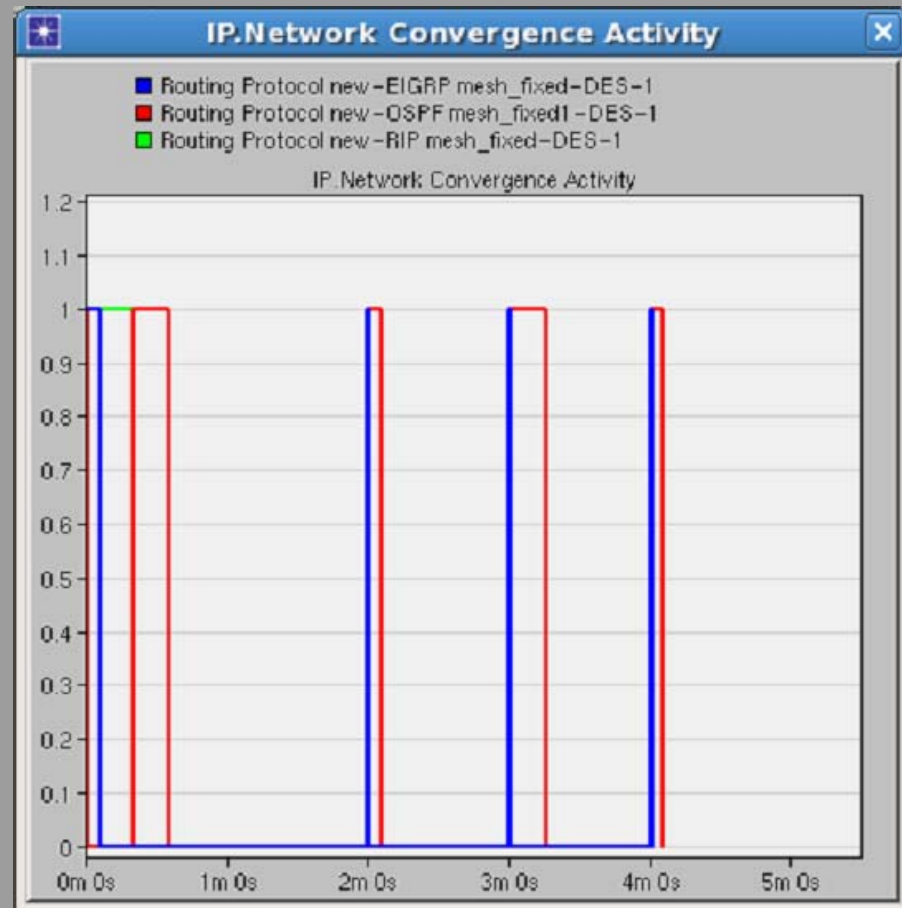

Convergence (large tree)

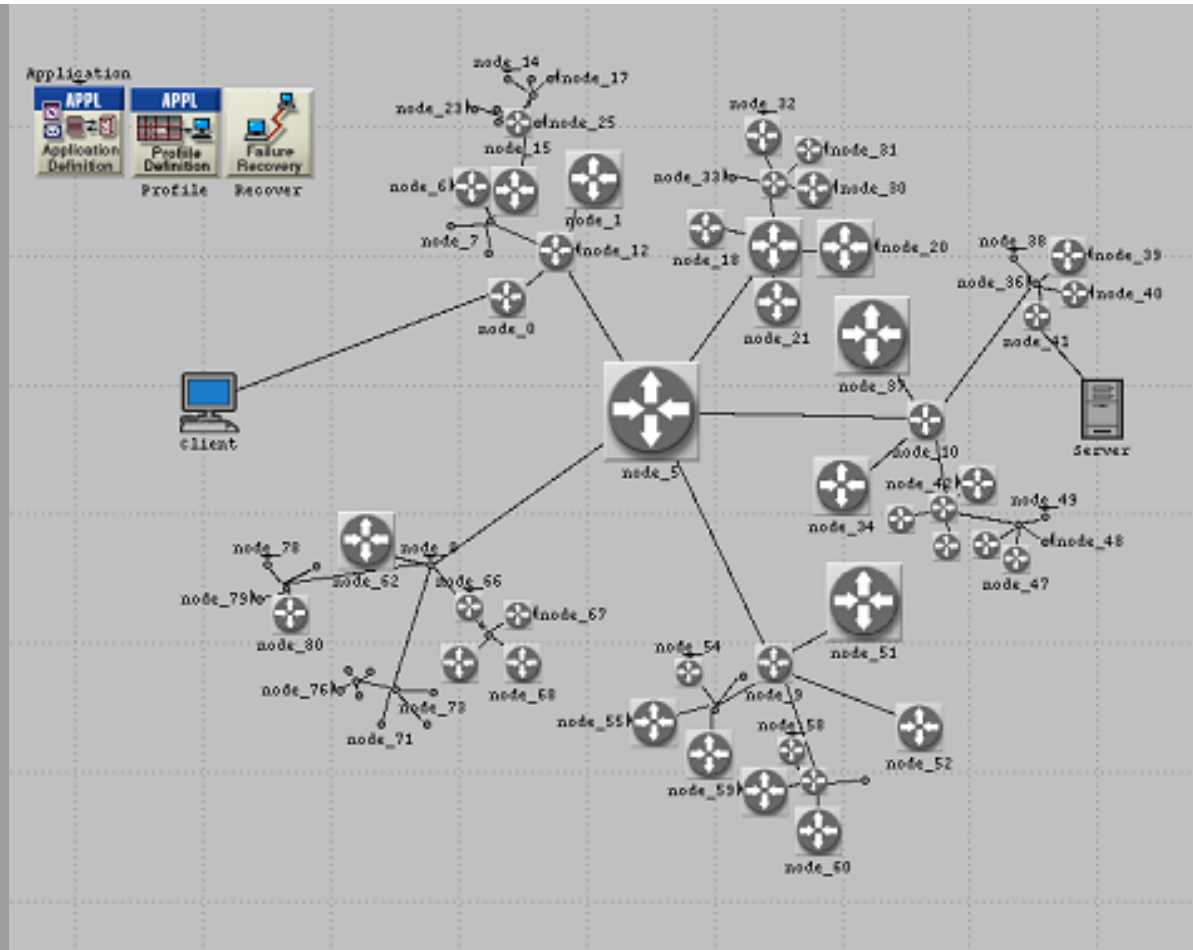

Convergence (large tree)

- Speed: EIGRP > OSPF > RIP

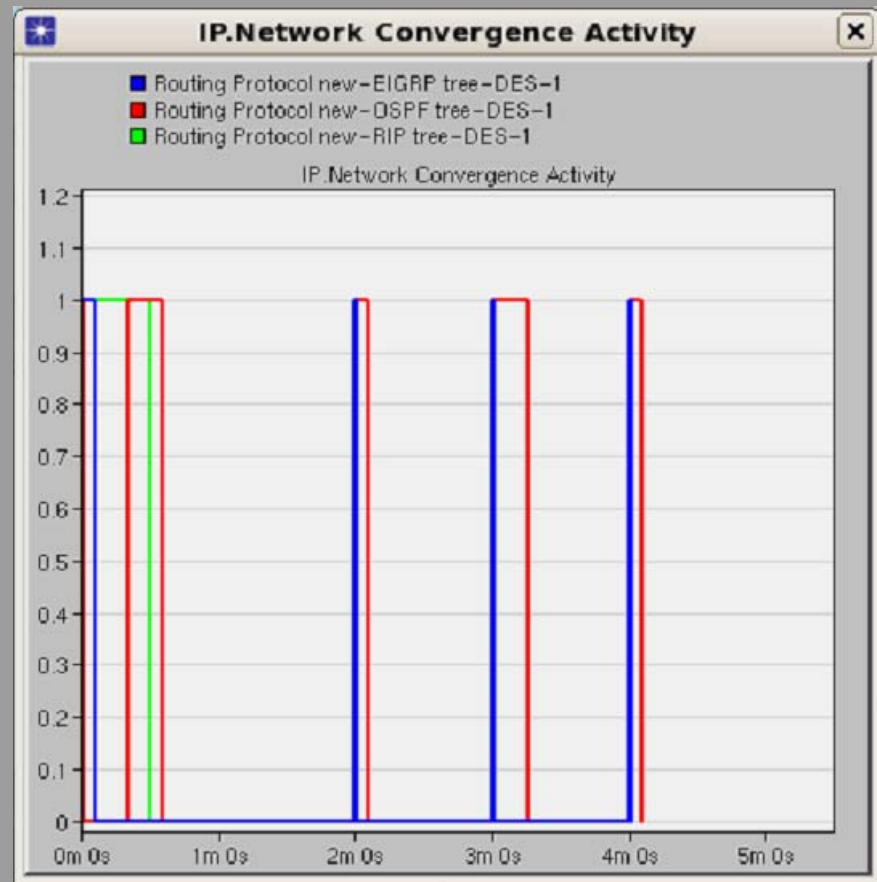

Why Not RIP?

- Limited by hop count
- Out of date algorithm
- Only works for small network

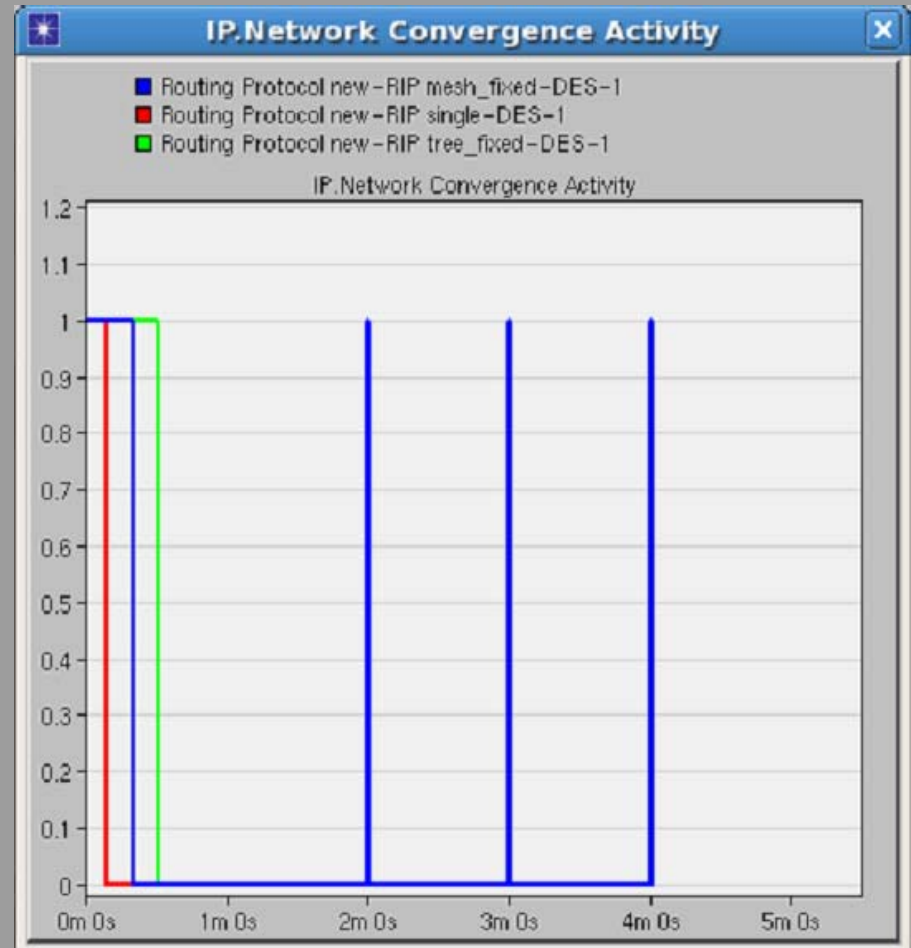

Why OSPF?

- No big difference in large or small network
- SPF chooses the shortest path to lower cost

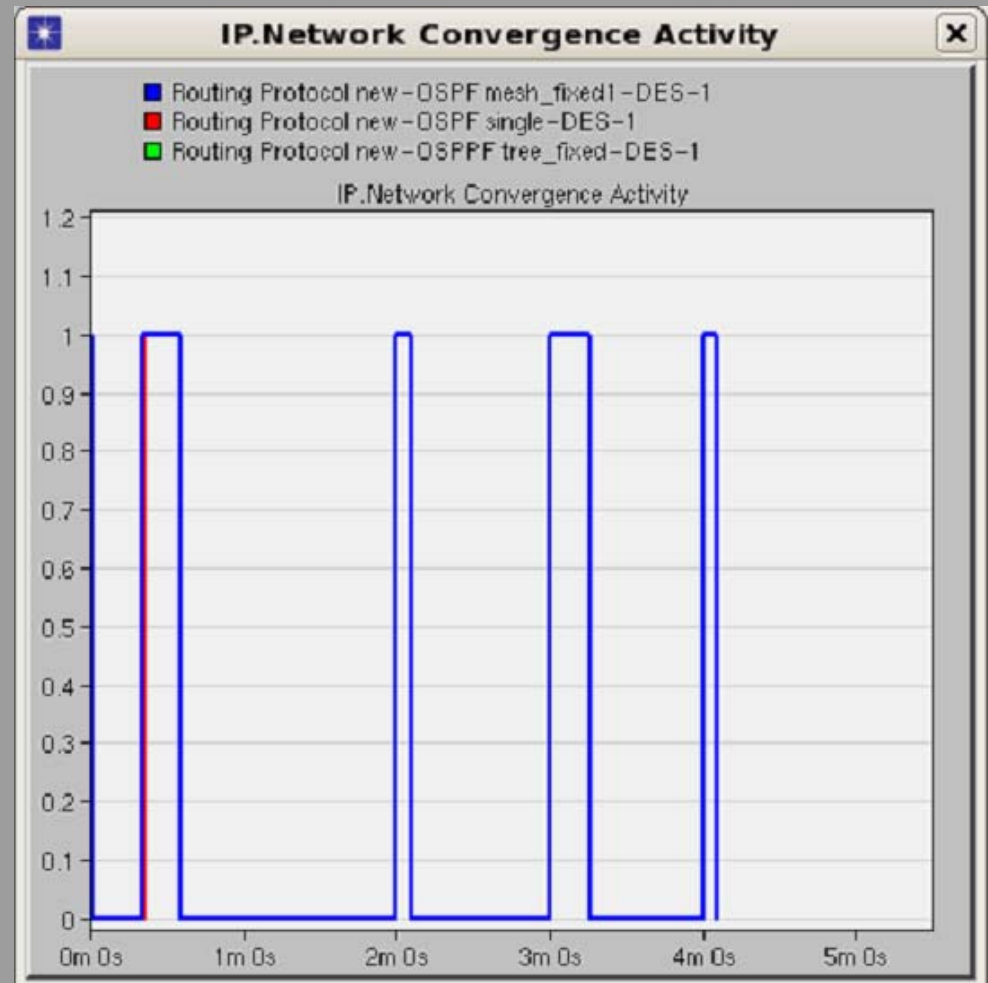

Why EIGRP?

- The fastest protocol
- Works for network in any sizes
- BUT, proprietary for CISCO

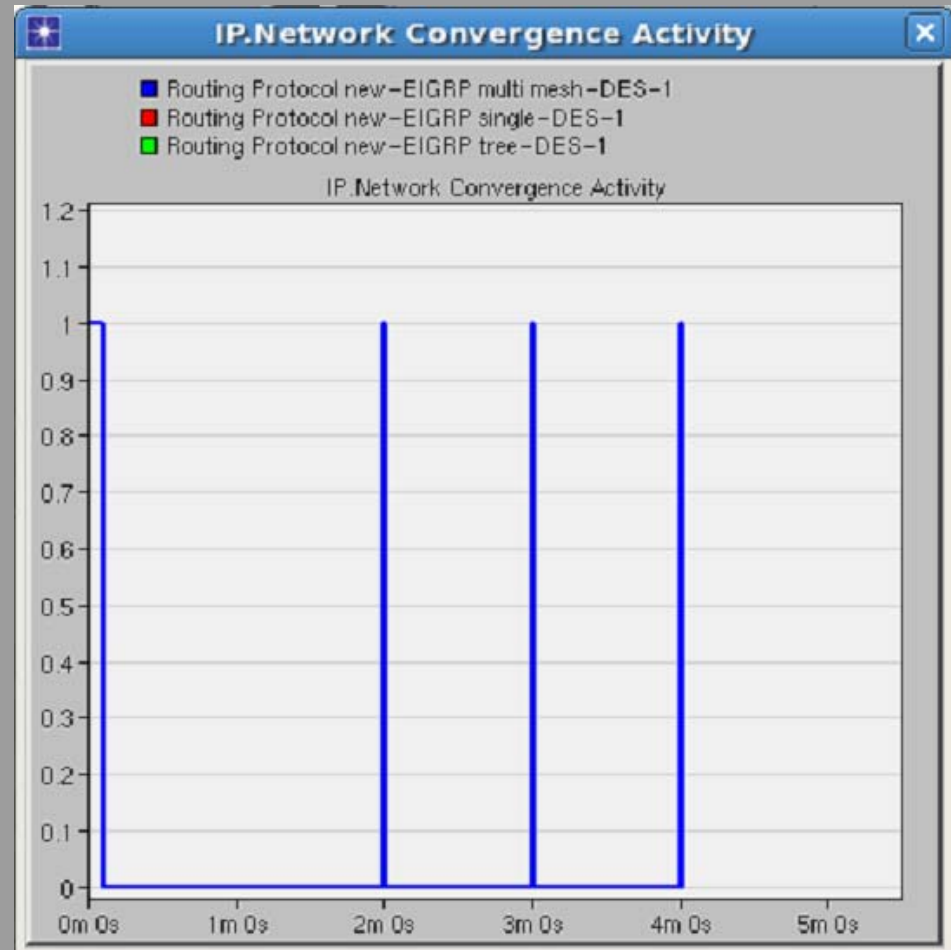

Discussion

- Convergence: EIGRP > OSPF > RIP
- Applicability: OSPF > EIGRP > RIP
- Cost: EIGRP > OSPF > RIP
- Application depends on the situation

References

- [1] Behrouz A. Forouzan, 'TCP/IP Protocol Suite,' 2009.
- [2] Pankaj Rakheja, Prabhjot Kaur, Anjali Gupta, Aditi Sharma, 'Performance Analysis of RIP, OSPF, IGRP and EIGRP Routing Protocols in a Network,' 2012.
- [3] Thorenoor, S. G, "'Dynamic Routing Protocol Implementation Decision between EIGRP, OSPF and RIP Based on Technical Background Using OPNET Modeler,' 2010, pp. 191-195.
- [4] Cisco, 'Cisco Active Network Abstraction 3.7 Reference Guide,' 2010, Chapter 10 pp. 393-396.
- [5] Scott M. Ballew, 'Managing IP Networks with Cisco Routers,' O' Reilly, 1997, Chapter 5.