

Chapter 4

Circuit-Switching

Networks

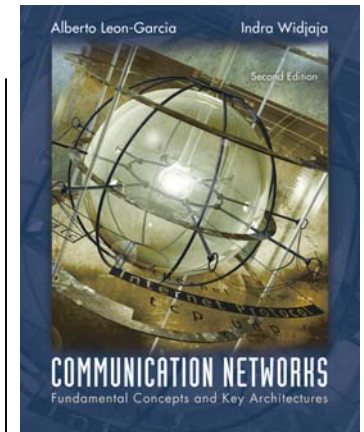

Multiplexing
SONET
Transport Networks
Circuit Switches
The Telephone Network
Signaling
Traffic and Overload Control in Telephone Networks
Cellular Telephone Networks

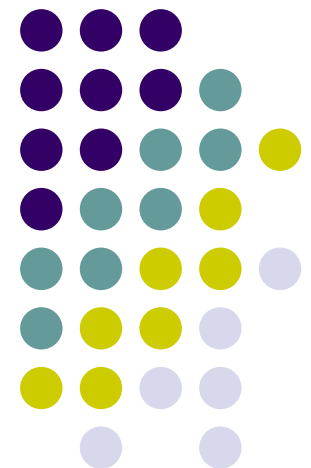

Circuit Switching Networks



- End-to-end dedicated circuits between clients
 - Client can be a person or equipment (router or switch)
- Circuit can take different forms
 - Dedicated path for the transfer of electrical current
 - Dedicated time slots for transfer of voice samples
 - Dedicated frames for transfer of Nx51.84 Mbps signals
 - Dedicated wavelengths for transfer of optical signals
- Circuit switching networks require:
 - Multiplexing & switching of circuits
 - Signaling & control for establishing circuits
- These are the subjects covered in this chapter

How a network grows

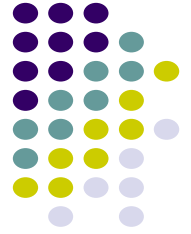

(a) A switch provides the network to a cluster of users, e.g. a telephone switch connects a local community

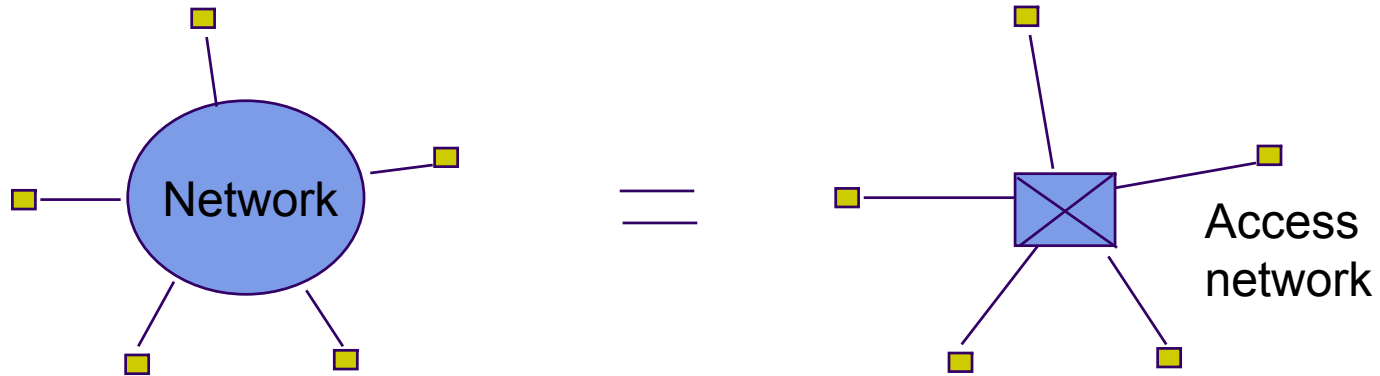

(b) A multiplexer connects two access networks, e.g. a high speed line connects two switches

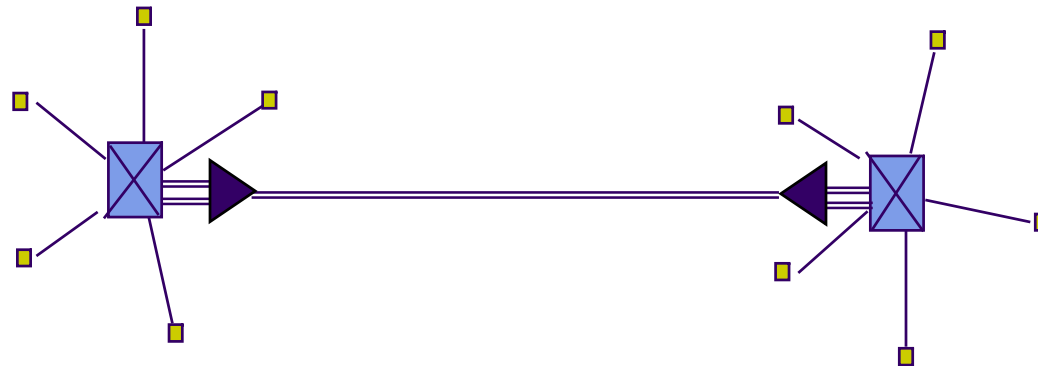

A Network Keeps Growing



(a) Metropolitan network **A** viewed as Network **A** of Access Subnetworks

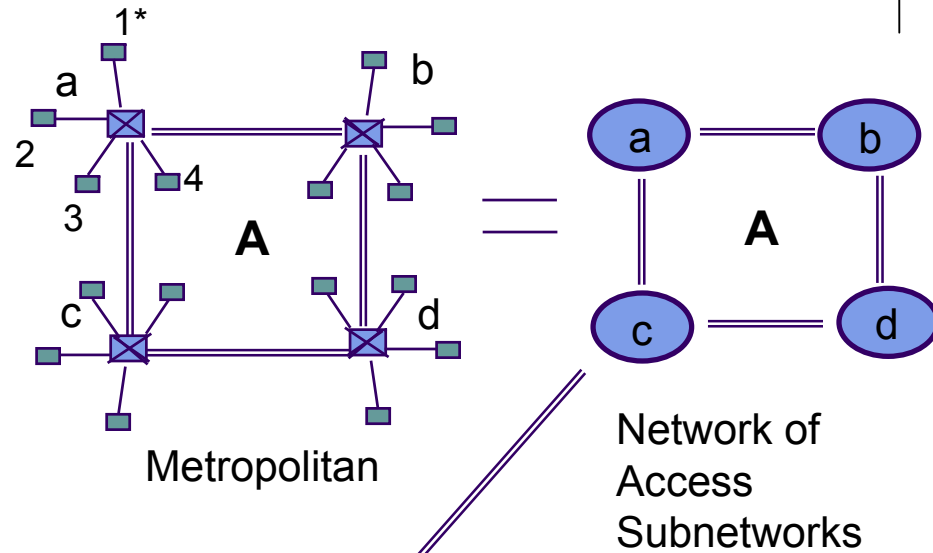

(b) National network viewed as Network of Regional Subnetworks (including **A**)

Very high-speed lines

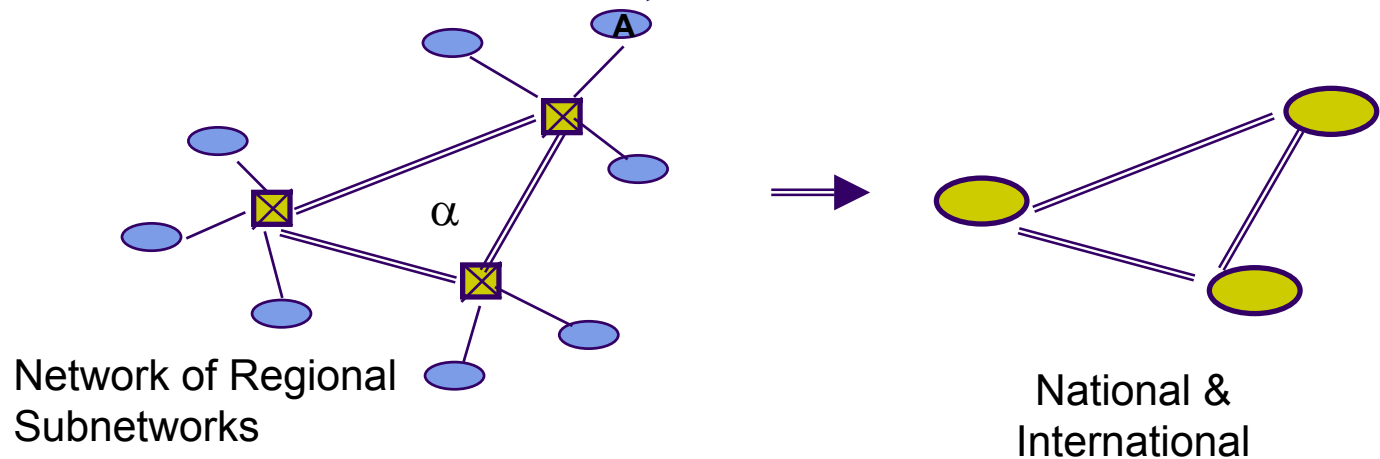

Chapter 4

Circuit-Switching Networks

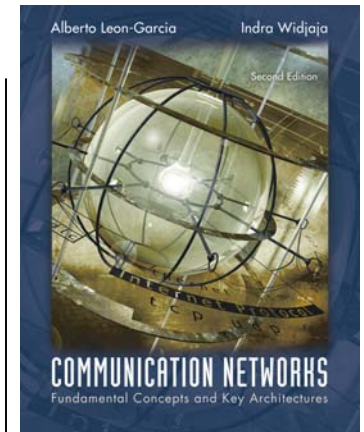

Multiplexing

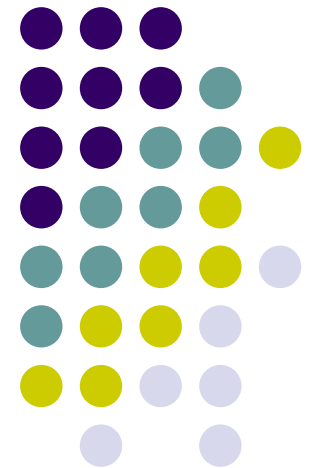

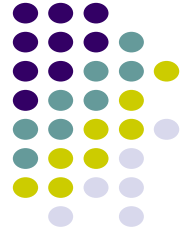

Multiplexing

- Multiplexing involves the sharing of a transmission channel (resource) by several connections or information flows
 - Channel = 1 wire, 1 optical fiber, or 1 frequency band
- Significant economies of scale can be achieved by combining many signals into one
 - Fewer wires/pole; fiber replaces thousands of cables
- Implicit or explicit information is required to demultiplex the information flows.

(a)

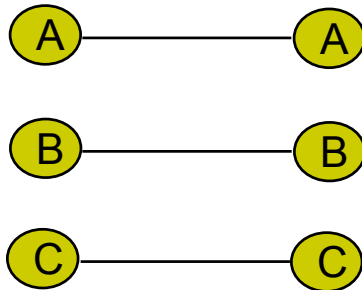

(b)

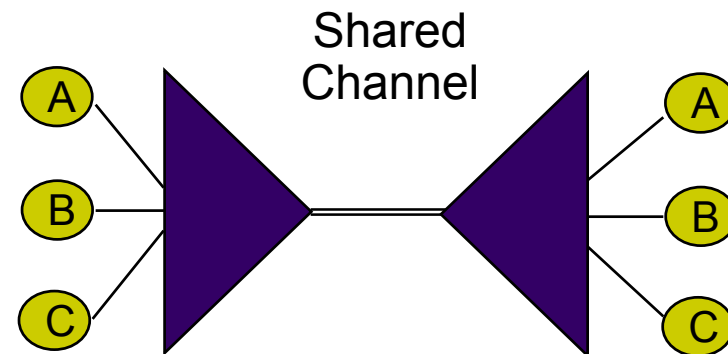

Frequency-Division Multiplexing

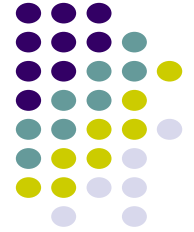

- Channel divided into frequency slots

(a) Individual signals occupy W_u Hz

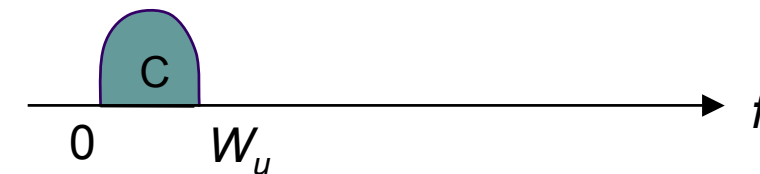
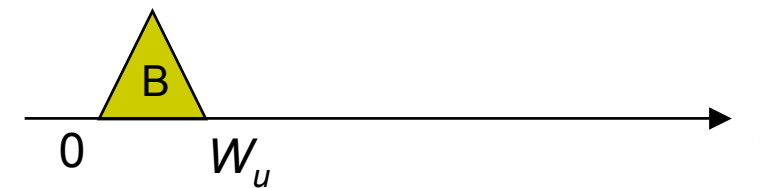
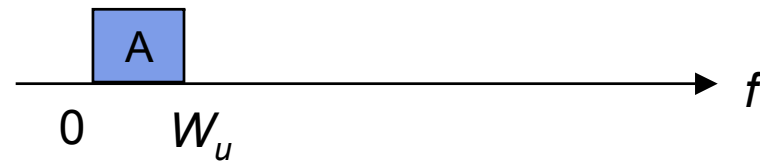

(b) Combined signal fits into channel bandwidth

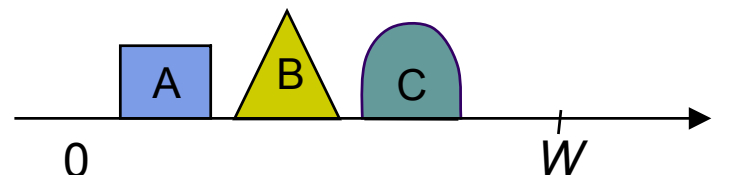

- Guard bands required
- AM or FM radio stations
- TV stations in air or cable
- Analog telephone systems

Time-Division Multiplexing

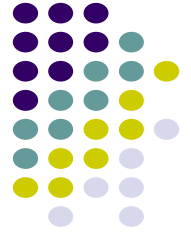

- High-speed digital channel divided into time slots

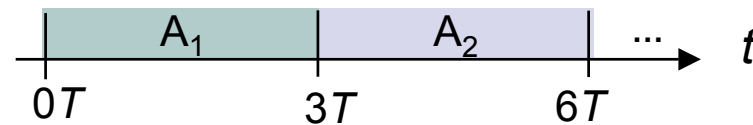

(a) Each signal transmits 1 unit every $3T$ seconds

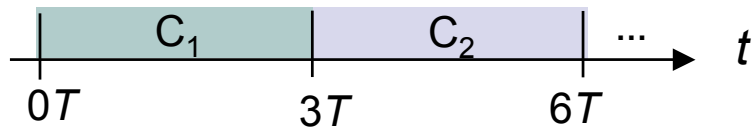
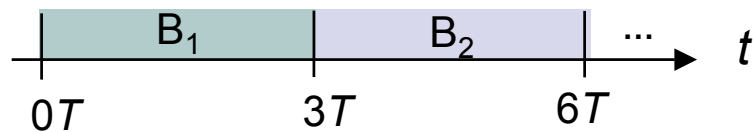

(b) Combined signal transmits 1 unit every T seconds

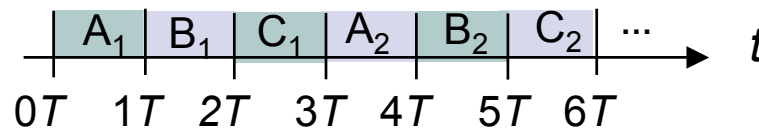

- Framing required
- Telephone digital transmission
- Digital transmission in backbone network



T-Carrier System

- Digital telephone system uses TDM.
- PCM voice channel is basic unit for TDM
 - 1 channel = 8 bits/sample x 8000 samples/sec. = 64 kbps
- T-1 carrier carries Digital Signal 1 (DS-1) that combines 24 voice channels into a digital stream:

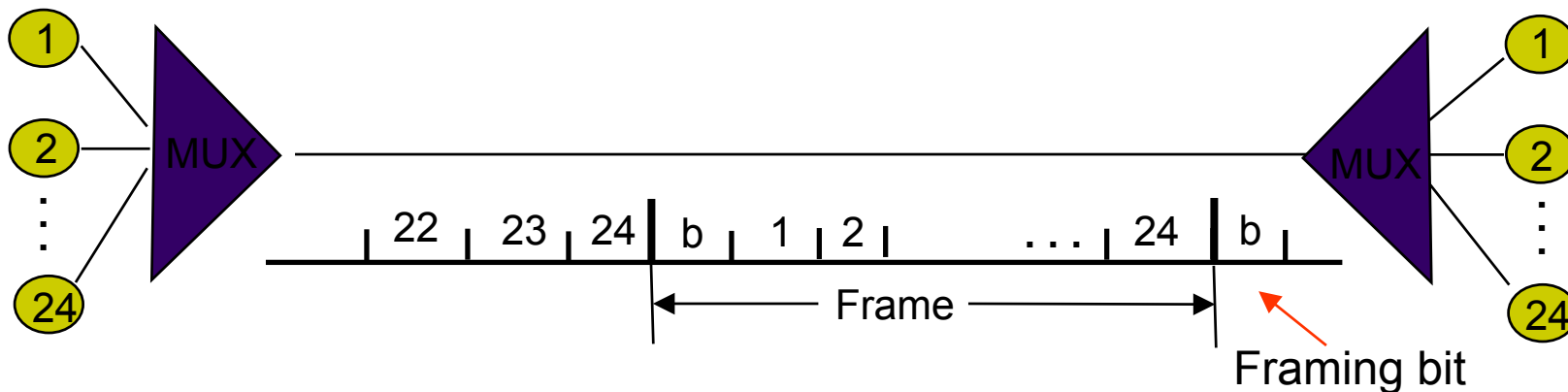

$$\begin{aligned}\text{Bit Rate} &= 8000 \text{ frames/sec.} \times (1 + 8 \times 24) \text{ bits/frame} \\ &= 1.544 \text{ Mbps}\end{aligned}$$

North American Digital Multiplexing Hierarchy

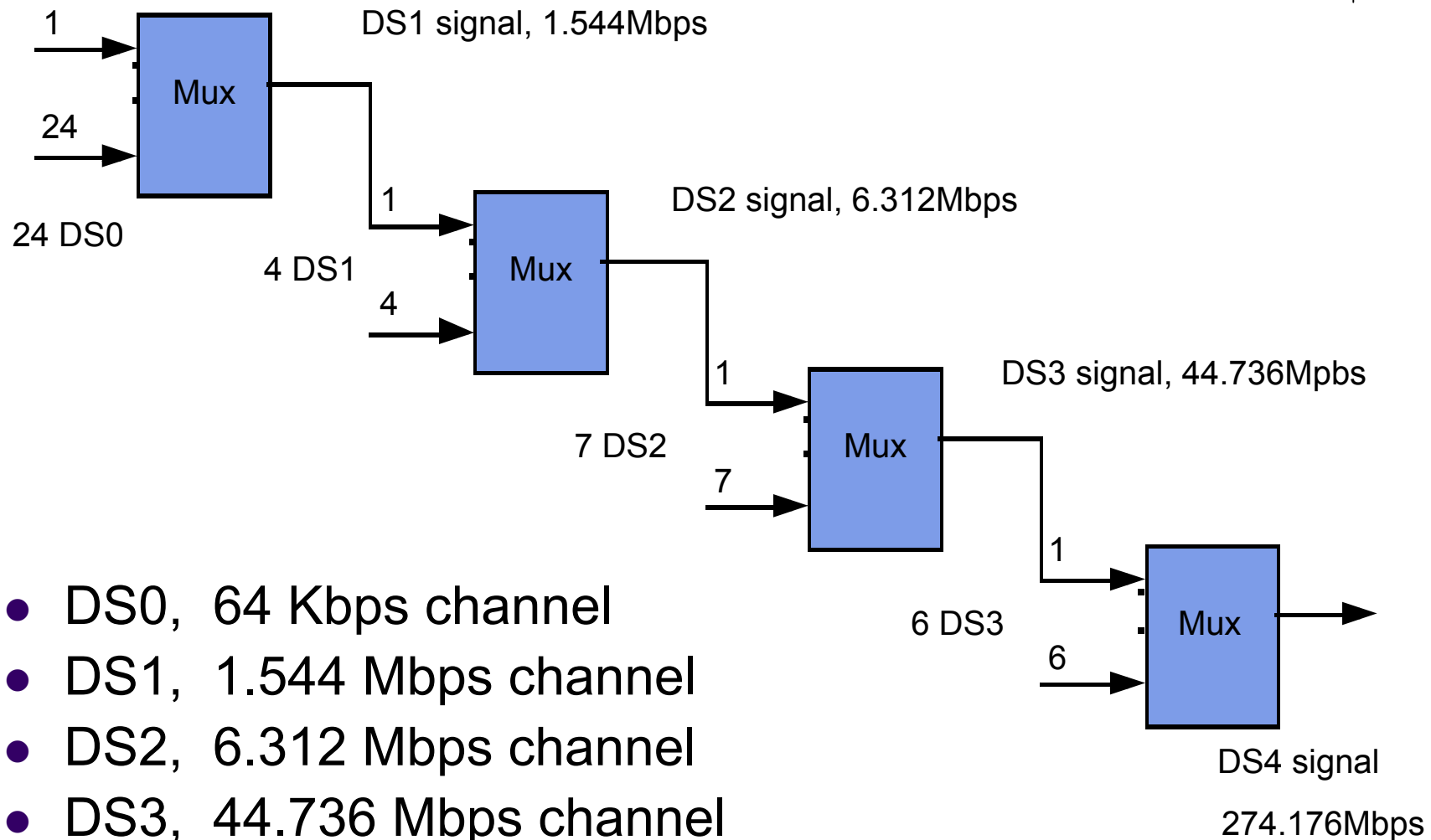
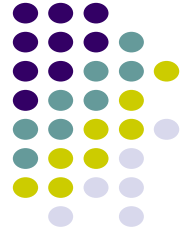

- DS0, 64 Kbps channel
- DS1, 1.544 Mbps channel
- DS2, 6.312 Mbps channel
- DS3, 44.736 Mbps channel
- DS4, 274.176 Mbps channel

CCITT Digital Hierarchy

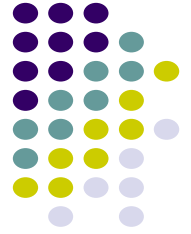

- CCITT digital hierarchy based on 30 PCM channels

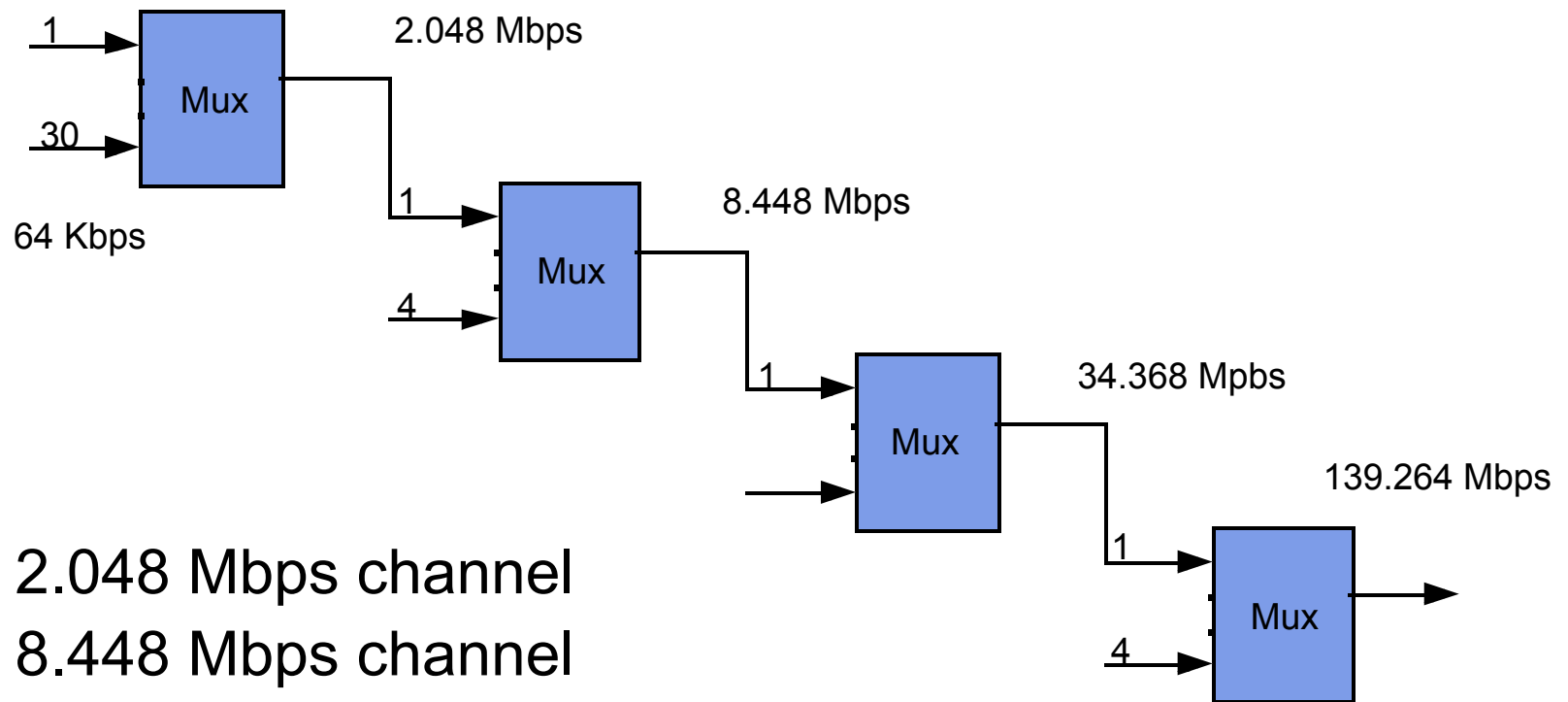

- E1, 2.048 Mbps channel
- E2, 8.448 Mbps channel
- E3, 34.368 Mbps channel
- E4, 139.264 Mbps channel

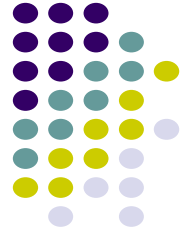

Clock Synch & Bit Slips

- Digital streams cannot be kept perfectly synchronized
- Bit slips can occur in multiplexers

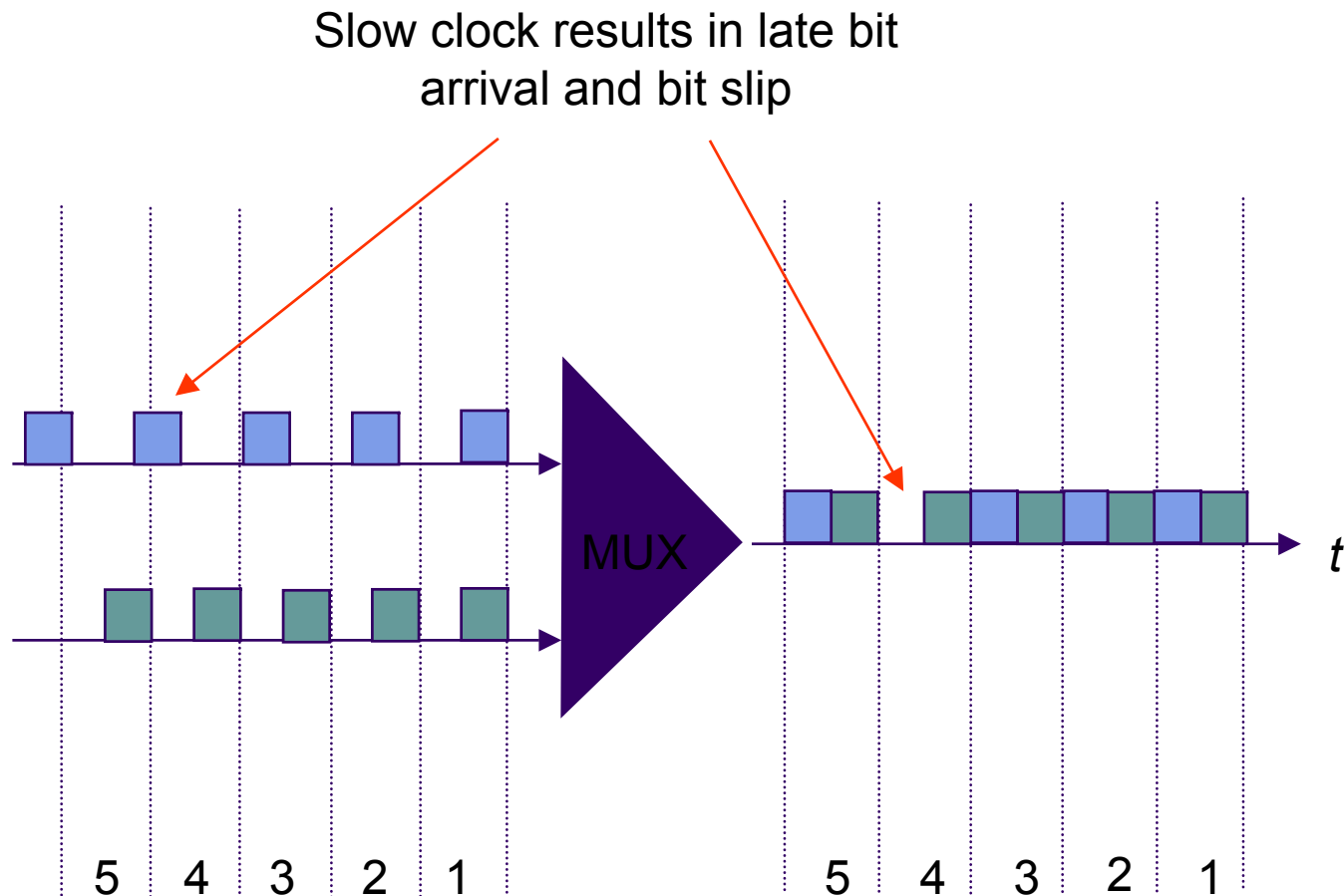



Pulse Stuffing

- Pulse Stuffing: synchronization to avoid data loss due to slips
- Output rate $> R1+R2$
 - i.e. DS2, 6.312Mbps=4x1.544Mbps + 136 Kbps
- Pulse stuffing format
 - Fixed-length master frames with each channel allowed to stuff or not to stuff a single bit in the master frame.
 - Redundant stuffing specifications
 - signaling or specification bits (other than data bits) are distributed across a master frame.

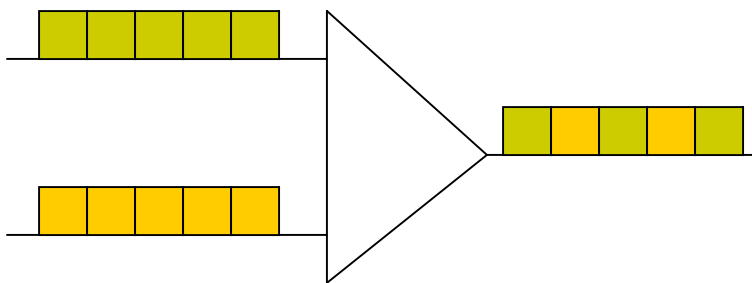

Muxing of equal-rate signals
requires perfect synch

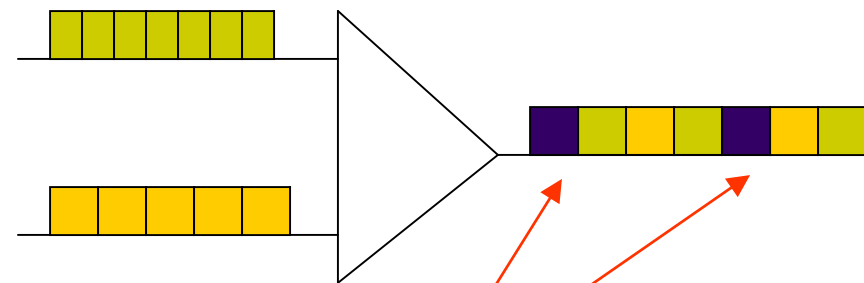

Pulse stuffing



Wavelength-Division Multiplexing

- Optical fiber link carries several wavelengths
 - From few (4-8) to many (64-160) wavelengths per fiber
- Imagine prism combining different colors into single beam
- Each wavelength carries a high-speed stream
 - Each wavelength can carry different format signal
 - e.g. 1 Gbps, 2.5 Gbps, or 10 Gbps

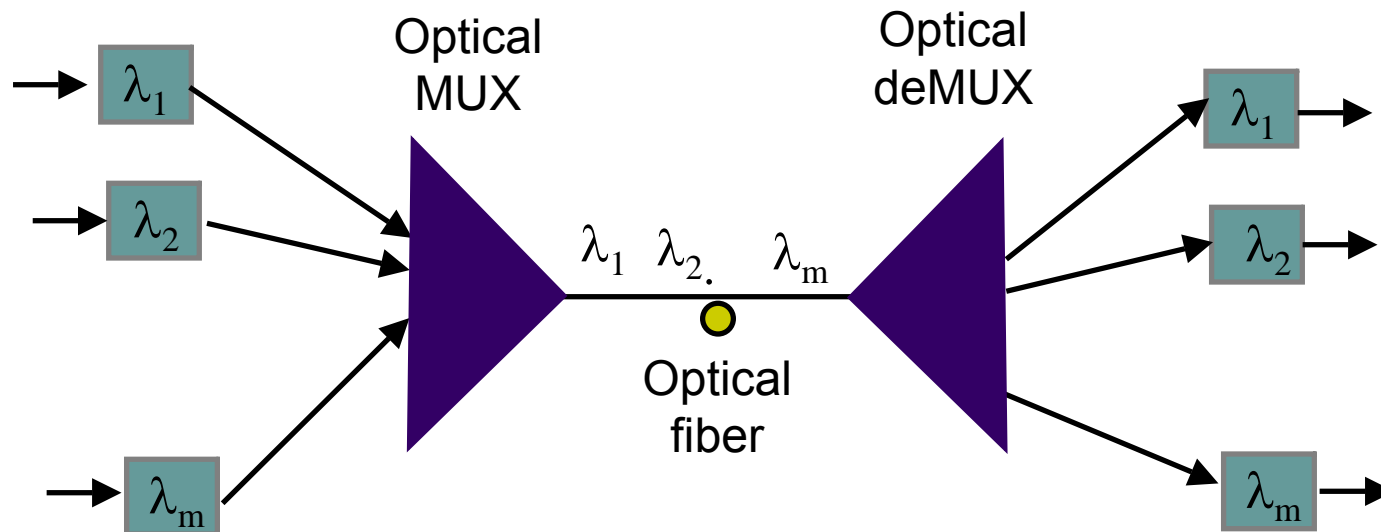

Example: WDM with 16 wavelengths

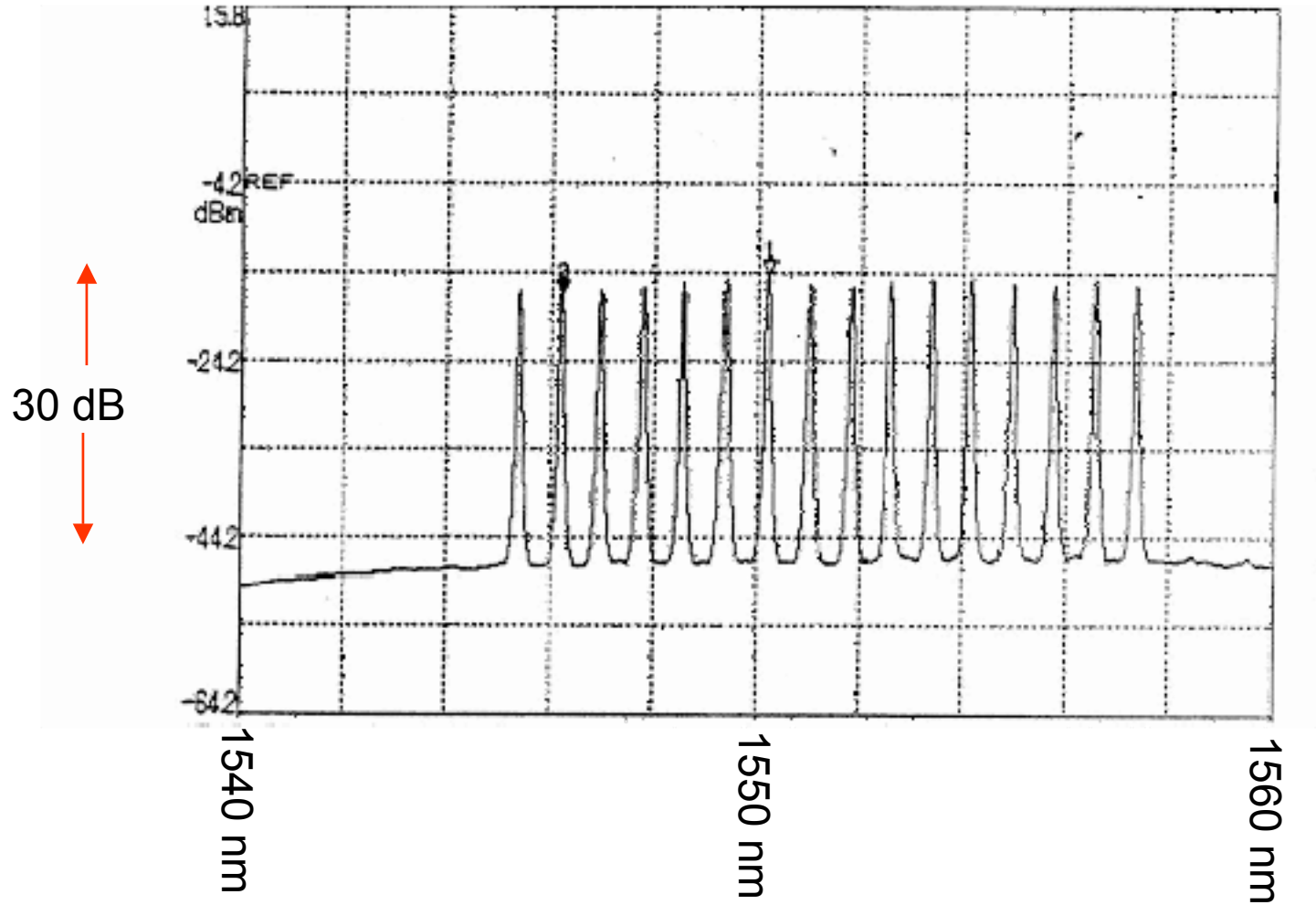
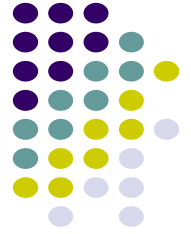

Typical U.S. Optical Long-Haul Network

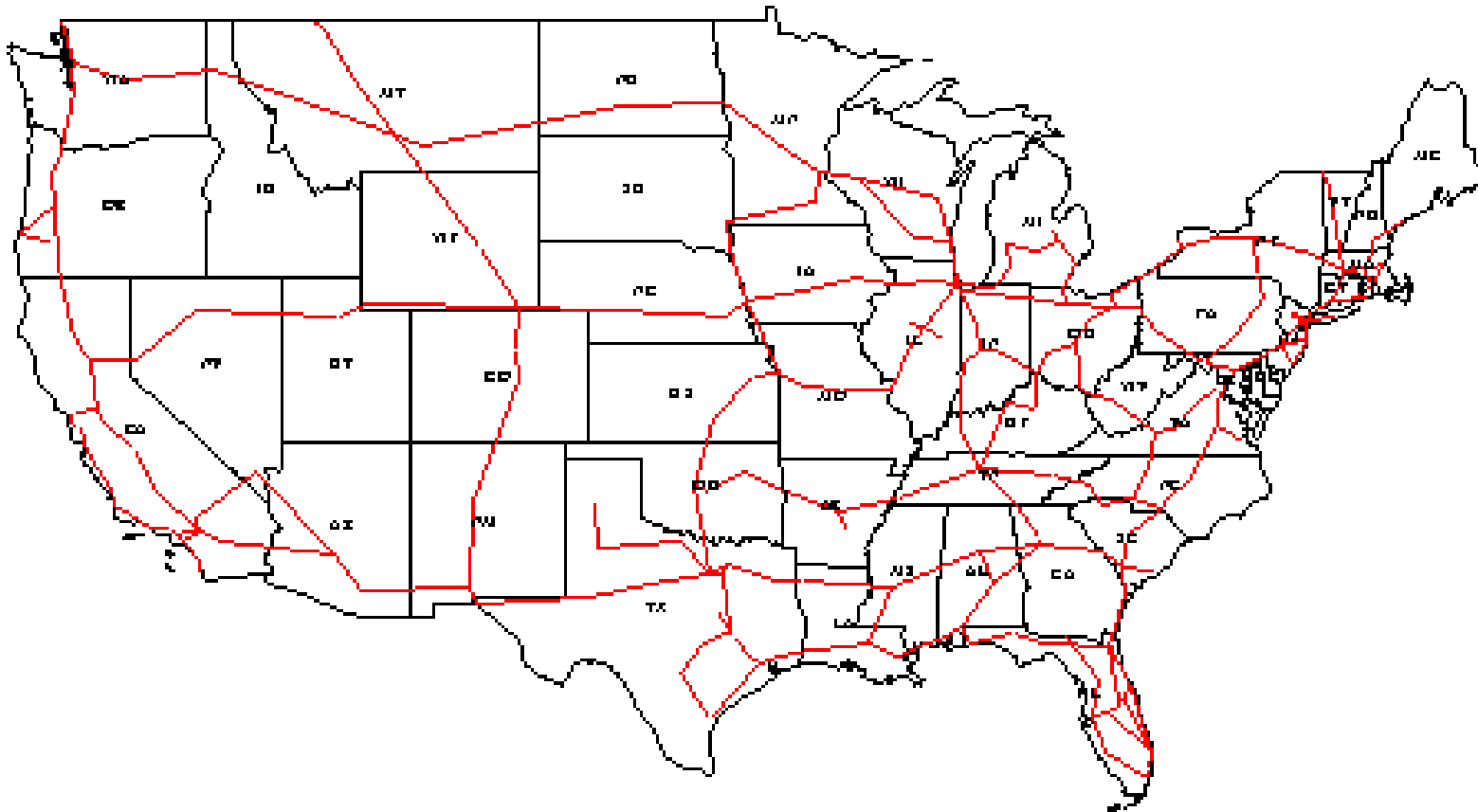

Chapter 4

Circuit-Switching Networks

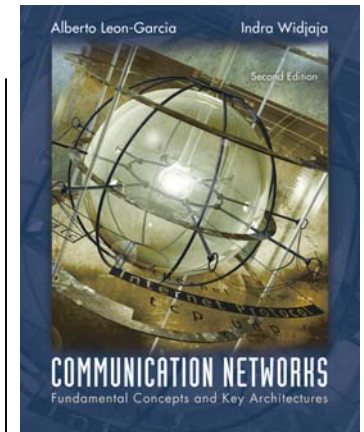

SONET

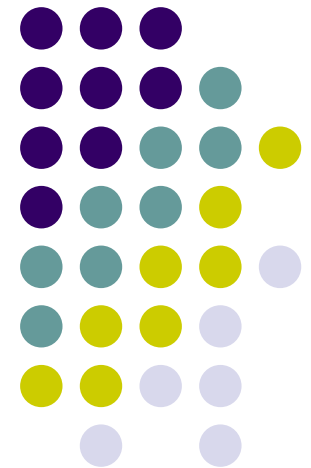

SONET: Overview

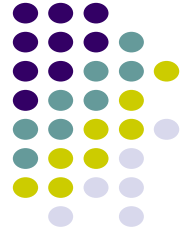

- *S*ynchronous *O*ptical *NET*work
- North American TDM physical layer standard for optical fiber communications
- 8000 frames/sec. ($T_{\text{frame}} = 125 \mu\text{sec}$)
 - compatible with North American digital hierarchy
- SDH (Synchronous Digital Hierarchy) elsewhere
 - Needs to carry E1 and E3 signals
 - Compatible with SONET at higher speeds
- Greatly simplifies multiplexing in network backbone
- OA&M support to facilitate network management
- Protection & restoration

SONET simplifies multiplexing



Pre-SONET multiplexing: Pulse stuffing required demultiplexing *all* channels

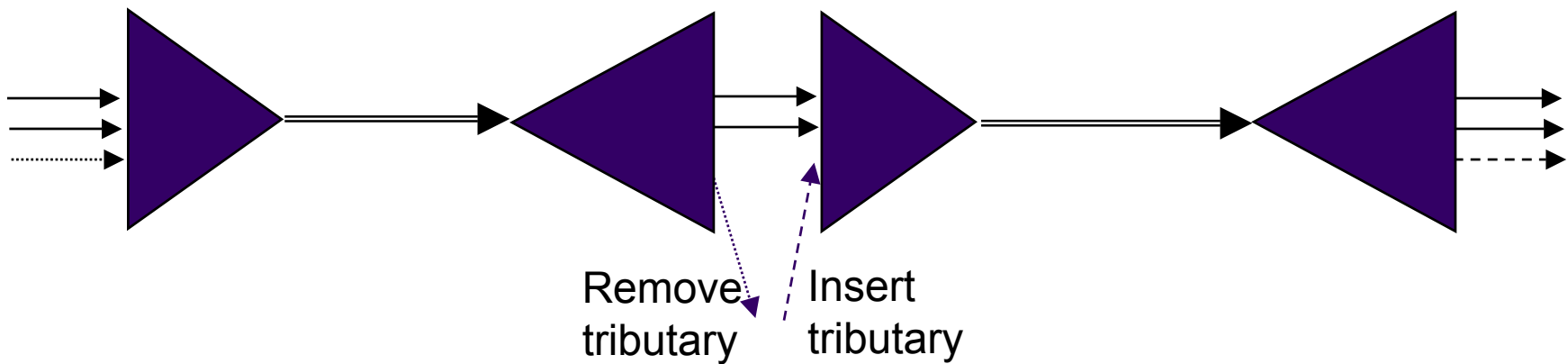

SONET Add-Drop Multiplexing: Allows taking individual channels in and out without full demultiplexing

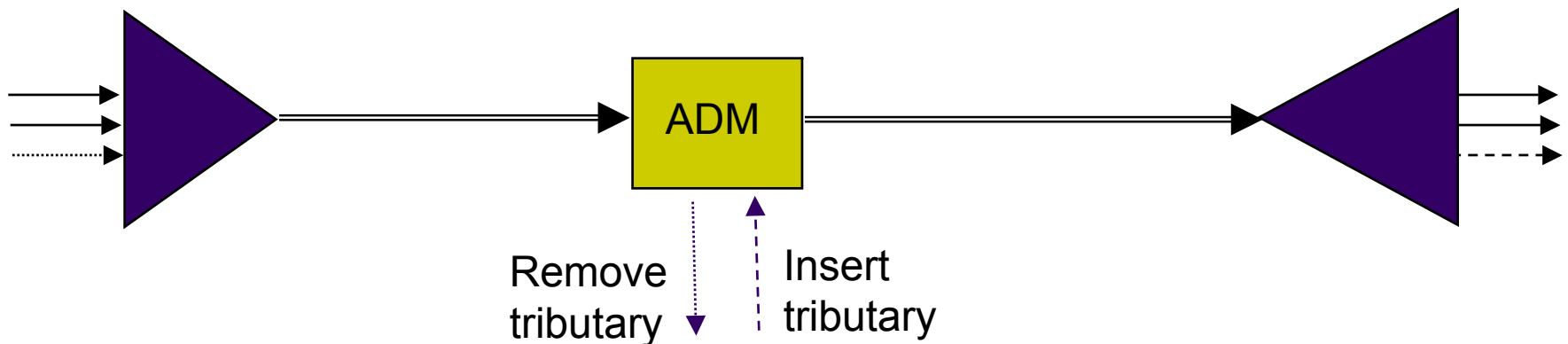

SONET Specifications



- Defines electrical & optical signal interfaces
- Electrical
 - Multiplexing, Regeneration performed in electrical domain
 - STS – Synchronous Transport Signals defined
 - Very short range (e.g., within a switch)
- Optical
 - Transmission carried out in optical domain
 - Optical transmitter & receiver
 - OC – Optical Carrier

SONET & SDH Hierarchy



<i>SONET Electrical Signal</i>	<i>Optical Signal</i>	<i>Bit Rate (Mbps)</i>	<i>SDH Electrical Signal</i>
STS-1	OC-1	51.84	N/A
STS-3	OC-3	155.52	STM-1
STS-9	OC-9	466.56	STM-3
STS-12	OC-12	622.08	STM-4
STS-18	OC-18	933.12	STM-6
STS-24	OC-24	1244.16	STM-8
STS-36	OC-36	1866.24	STM-12
STS-48	OC-48	2488.32	STM-16
STS-192	OC-192	9953.28	STM-64
<i>STS: Synchronous Transport Signal</i>	<i>OC: Optical Channel</i>		<i>STM: Synchronous Transfer Module</i>

SONET Multiplexing

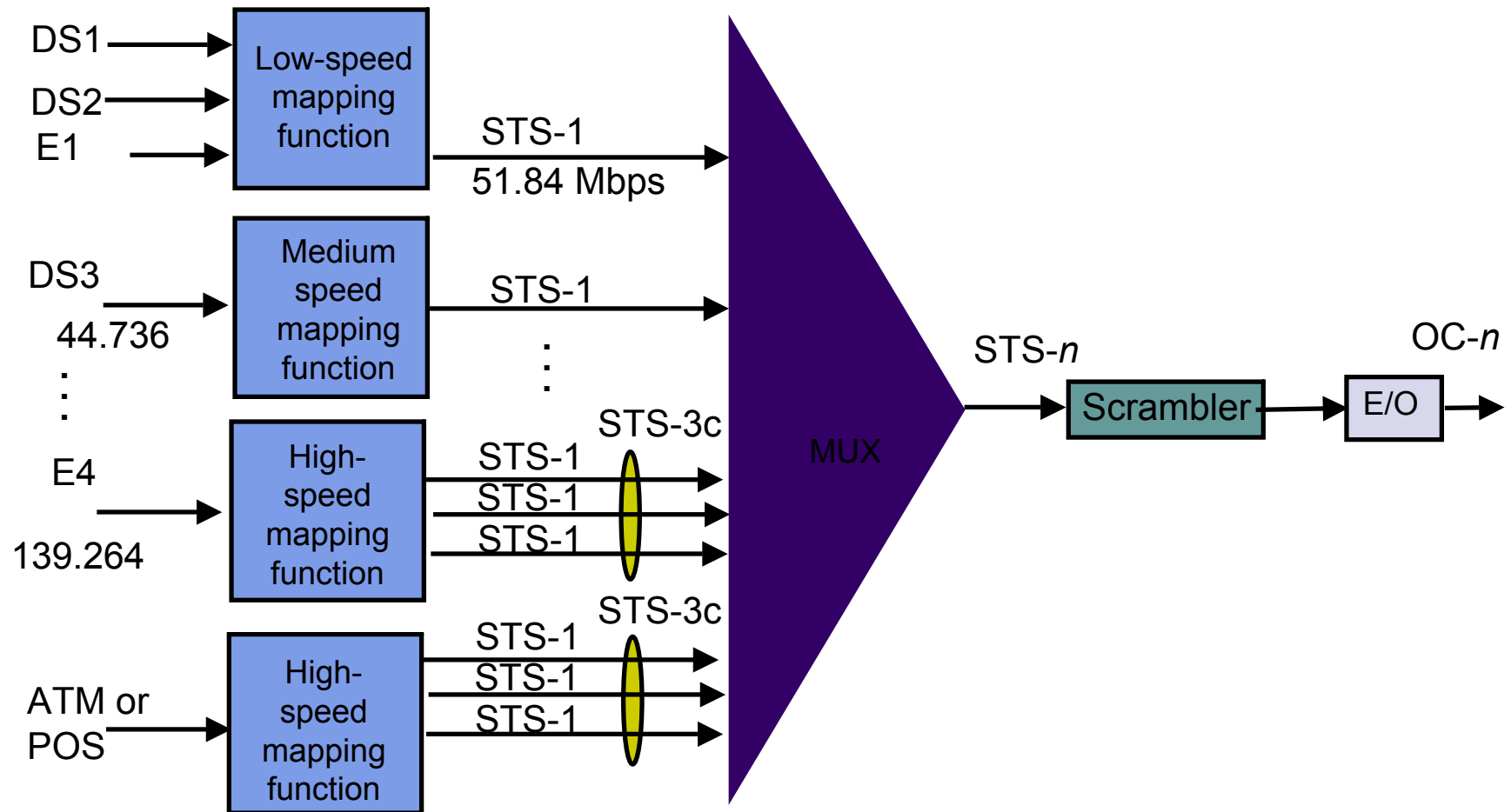
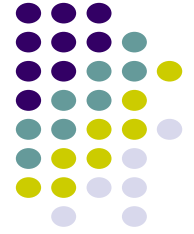

SONET Equipment

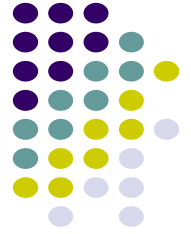

- By Functionality
 - ADMs: dropping & inserting tributaries
 - Regenerators: digital signal regeneration
 - Cross-Connects: interconnecting SONET streams
- By Signaling between elements
 - Section Terminating Equipment (STE): span of fiber between adjacent devices, e.g. regenerators
 - Line Terminating Equipment (LTE): span between adjacent multiplexers, encompasses multiple sections
 - Path Terminating Equipment (PTE): span between SONET terminals at end of network, encompasses multiple lines

Section, Line, & Path in SONET

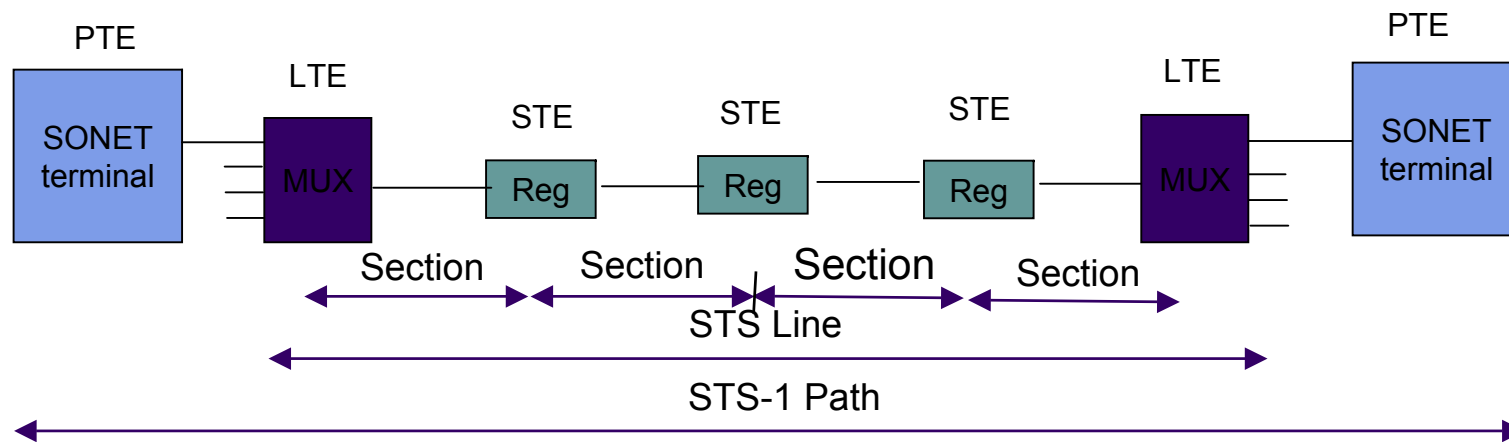

STE = Section Terminating Equipment, e.g., a repeater/regenerator
LTE = Line Terminating Equipment, e.g., a STS-1 to STS-3 multiplexer
PTE = Path Terminating Equipment, e.g., an STS-1 multiplexer

- Often, PTE and LTE equipment are the same
 - Difference is based on function and location
 - PTE is at the ends, e.g., STS-1 multiplexer.
 - LTE in the middle, e.g., STS-3 to STS-1 multiplexer.

Section, Line, & Path Layers in SONET

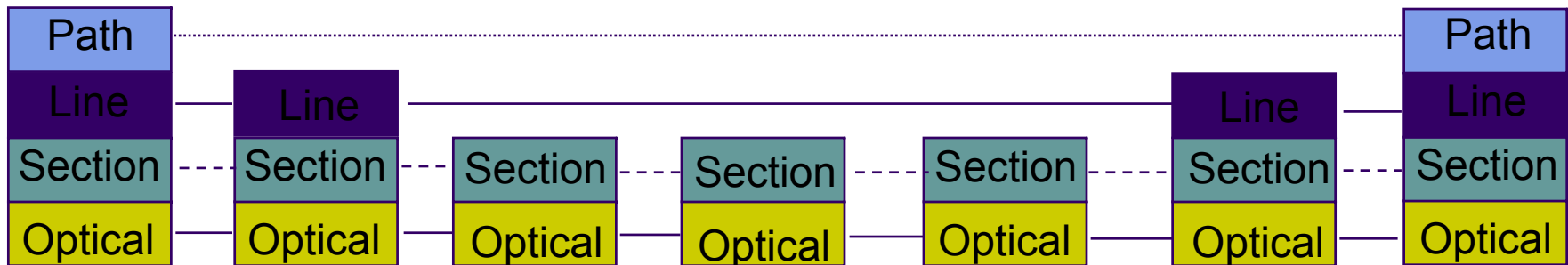

- SONET has four layers
 - Optical, section, line, path
 - Each layer is concerned with the integrity of its own signals
- Each layer has its own protocols
 - SONET provides signaling channels for elements within a layer

SONET STS Frame

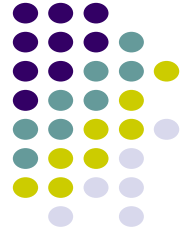

- SONET streams carry two types of overhead
- *Path overhead (POH)*:
 - inserted & removed at the ends
 - *Synchronous Payload Envelope (SPE)* consisting of Data + POH traverses network as a single unit
- *Transport Overhead (TOH)*:
 - processed at every SONET node
 - TOH occupies a portion of each SONET frame
 - TOH carries management & link integrity information

STS-1 Frame

810x64kbps=51.84 Mbps
810 Octets per frame @ 8000 frames/sec

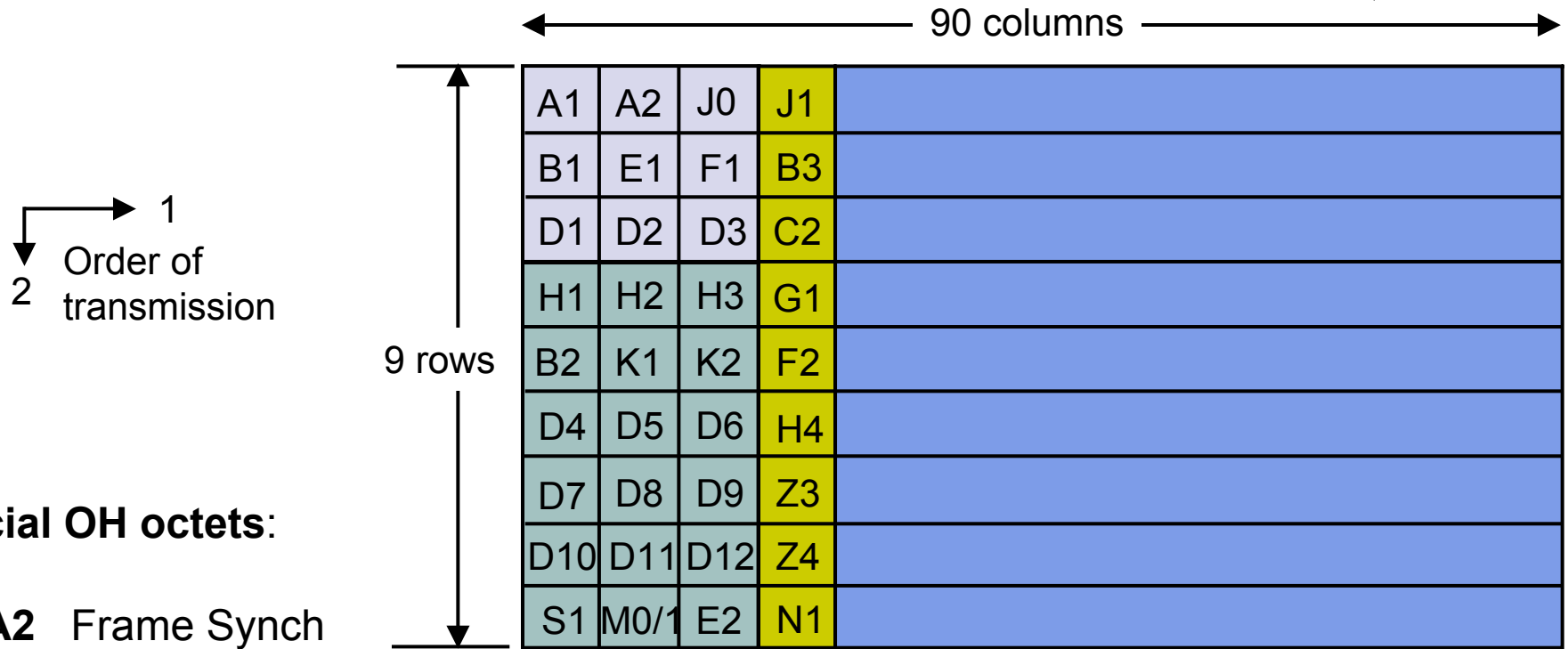

Special OH octets:

- A1, A2** Frame Synch
- B1** Parity on Previous Frame (BER monitoring)
- J0** Section trace (Connection Alive?)
- H1, H2, H3** Pointer Action
- K1, K2** Automatic Protection Switching

3 Columns of Transport OH

Synchronous Payload Envelope (SPE)
1 column of Path OH + 8 data columns

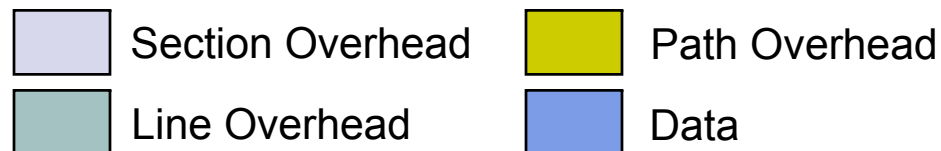

SPE Can Span Consecutive Frames

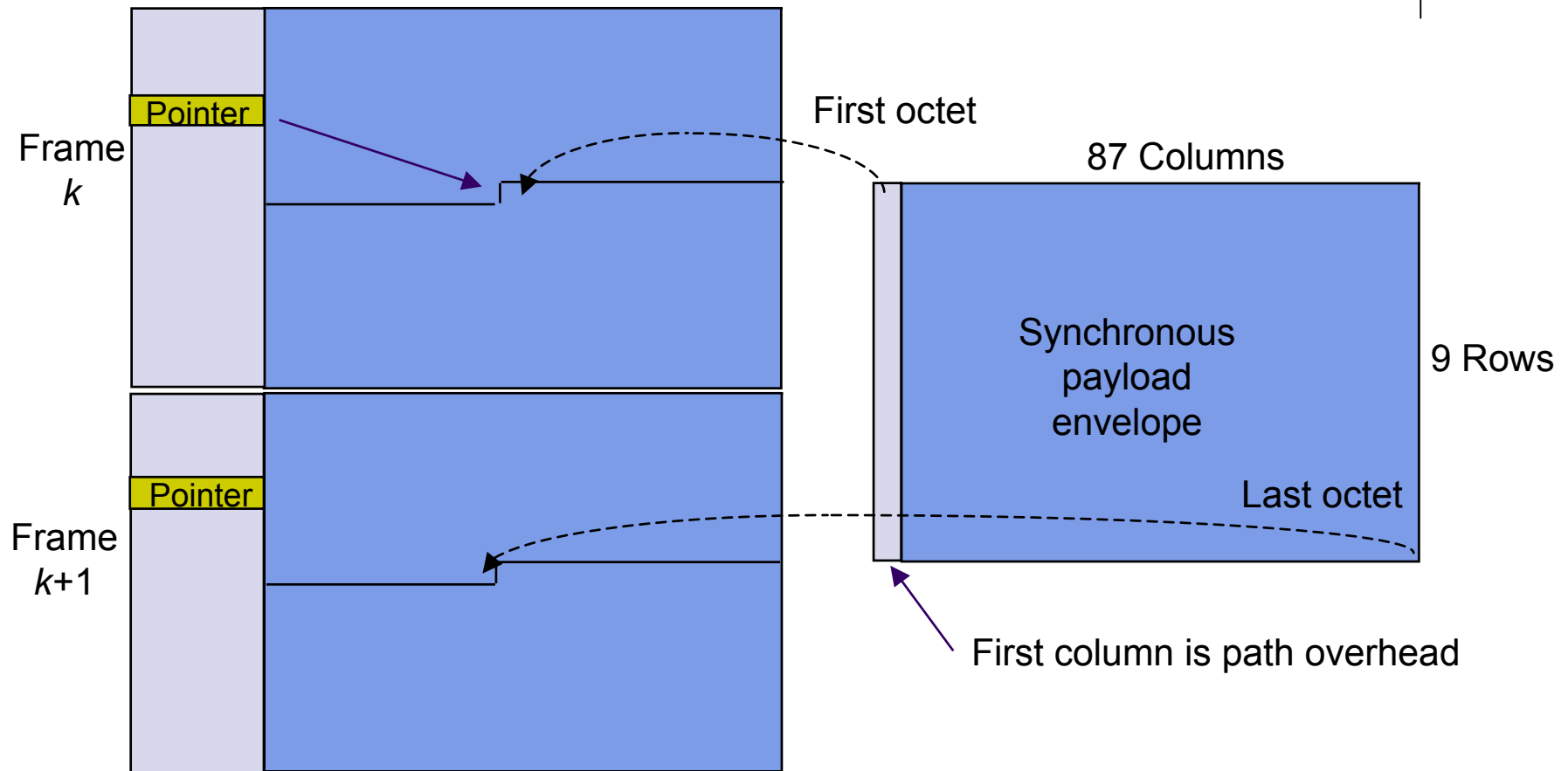

- Pointer indicates where SPE begins within a frame
- ***Pointer enables add/drop capability***



Stuffing in SONET

- Consider system with different clocks (faster out than in)
- Use buffer (e.g., 8 bit FIFO) to manage difference
- Buffer empties eventually
- One solution: send “stuff”
- Problem:
 - Need to signal “stuff” to receiver

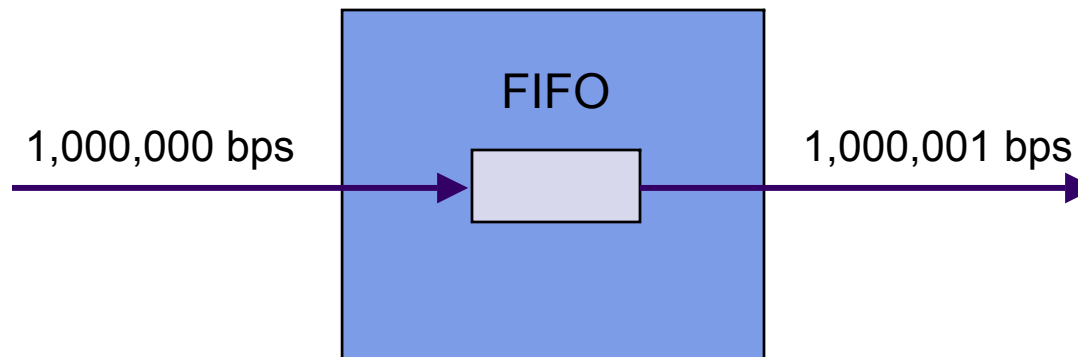



Negative & Positive Stuff

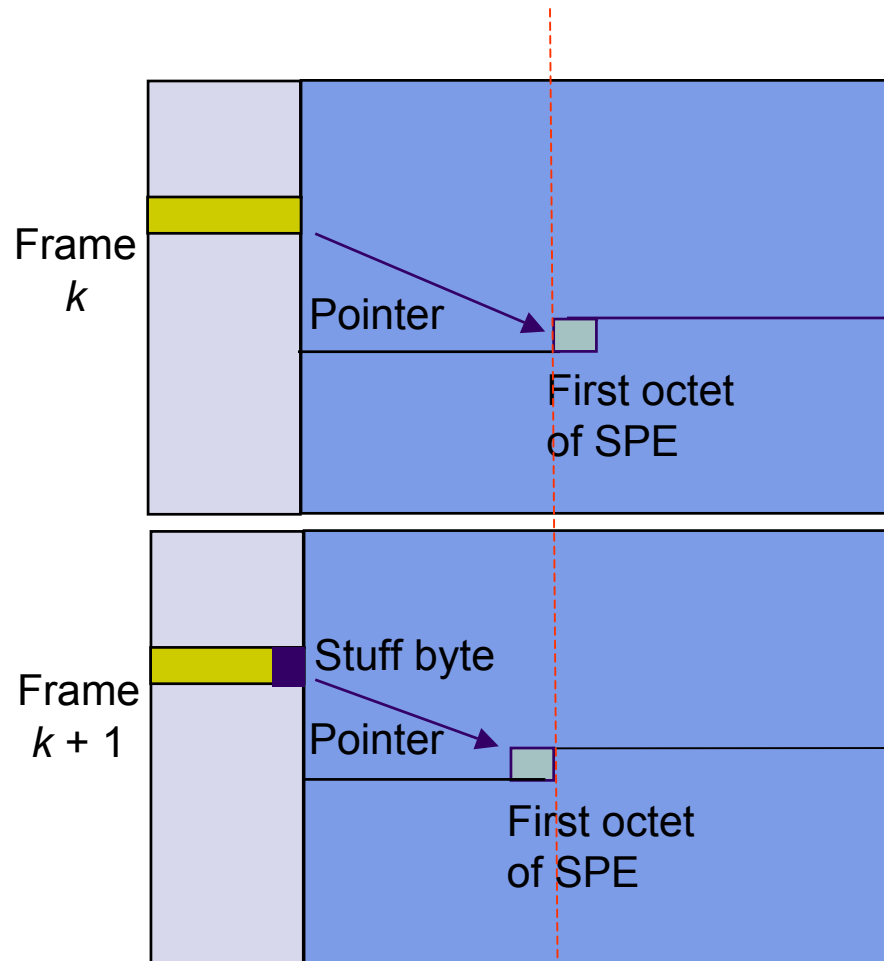

(a) Negative byte stuffing
Input faster than output
Send extra byte in H3 to catch up

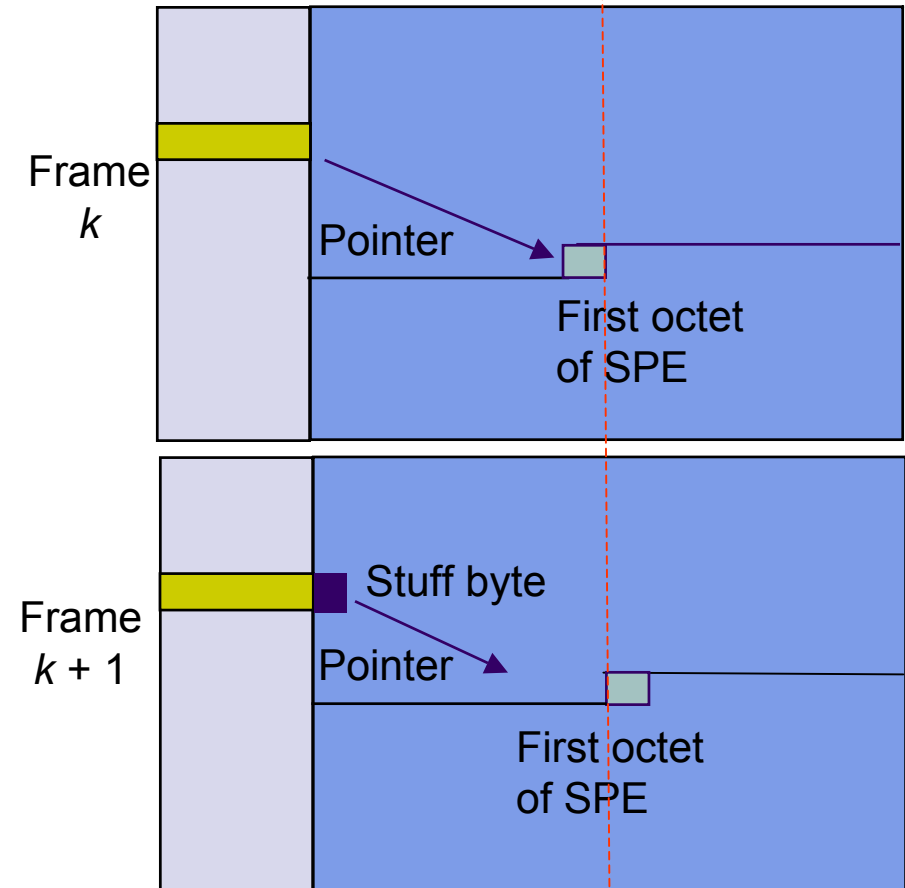

(b) Positive byte stuffing
Input is slower than output
Stuff byte to fill gap



Synchronous Multiplexing

- Synchronize each incoming STS-1 to local clock
 - Terminate section & line OH and map incoming SPE into a *new* STS-1 synchronized to the *local* clock
 - This can be done on-the-fly by adjusting the pointer
- All STS-1s are synched to local clock so bytes can be interleaved to produce STS-n

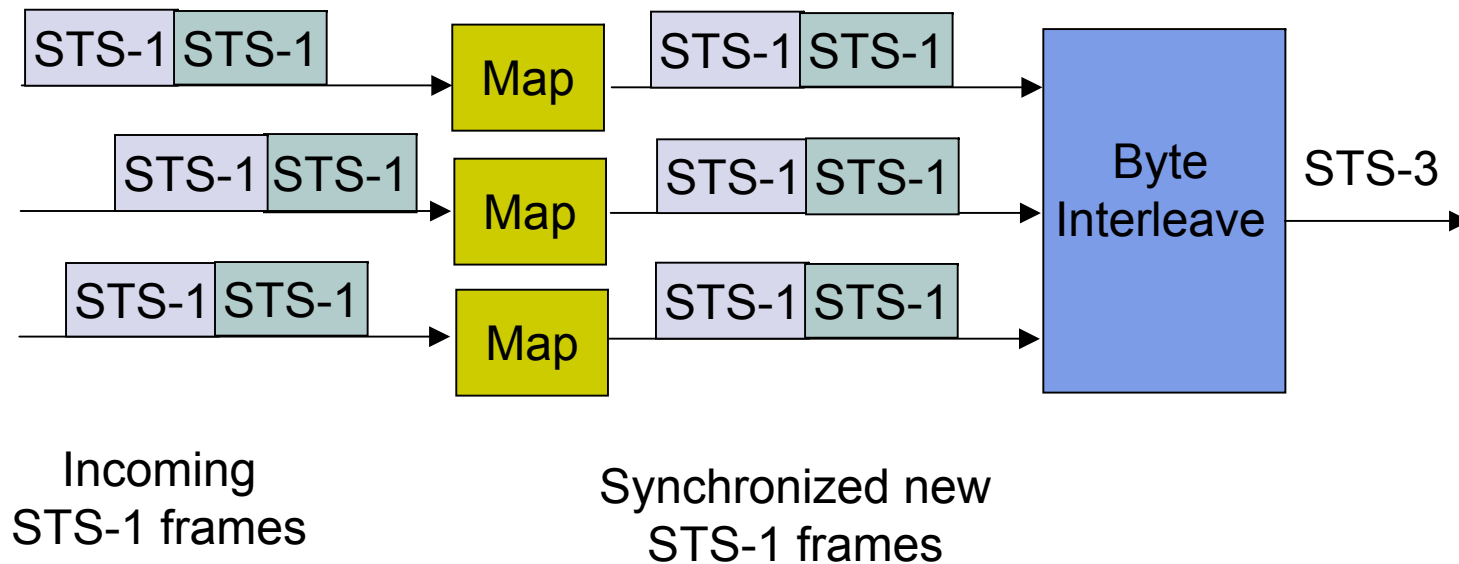

Octet Interleaving

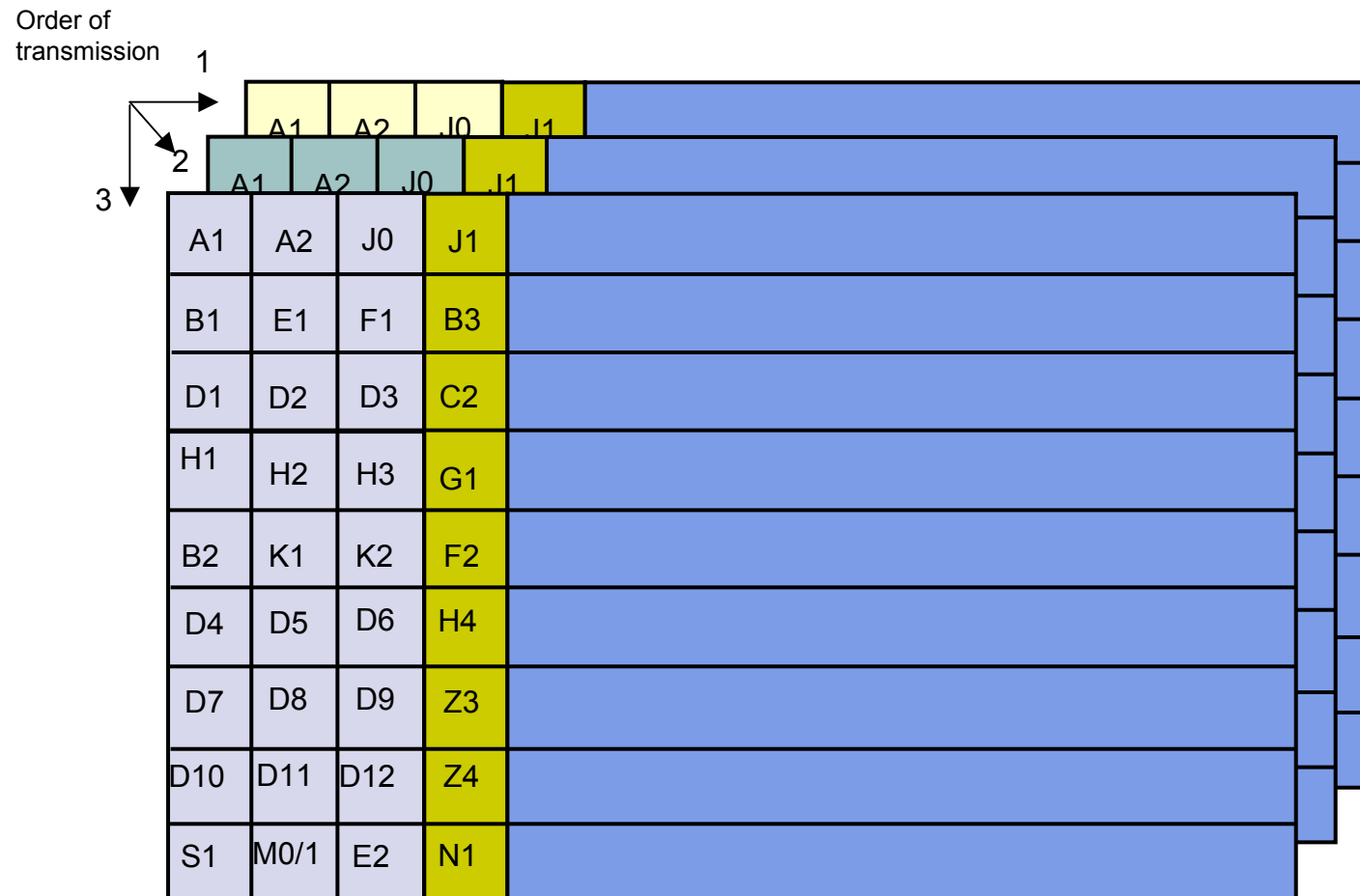



Concatenated Payloads

Concatenated Payload OC-Nc

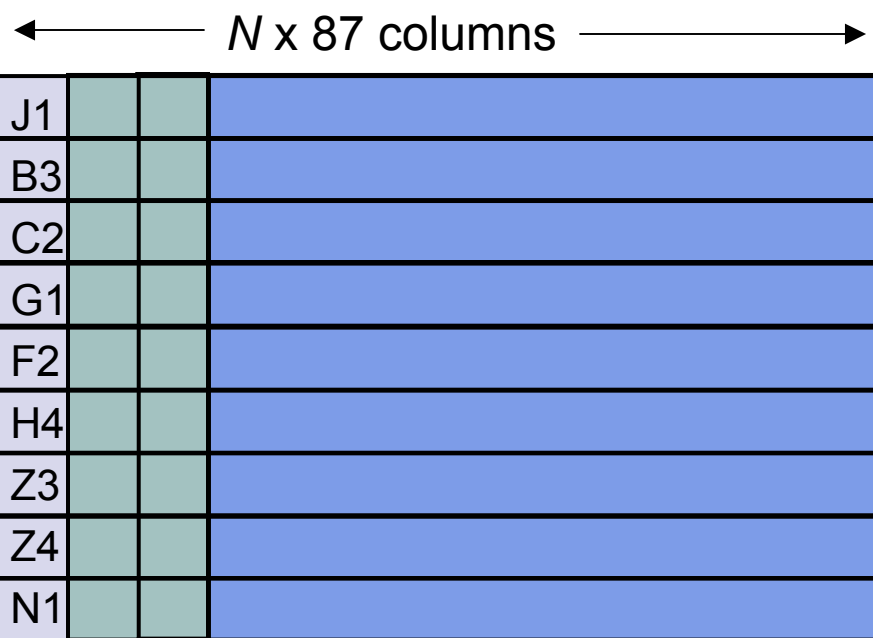

$(N/3) - 1$
columns of
fixed stuff

$87N - (N/3)$
columns of
payload

- Needed if payloads of interleaved frames are “locked” into a bigger unit
- Data systems send big blocks of information grouped together, e.g., a router operating at 622 Mbps
 - SONET/SDH needs to handle these as a single unit
- H1,H2,H3 tell us if there is concatenation
- STS-3c has more payload than 3 STS-1s
- STS-Nc payload = $N \times 780$ bytes
- OC-3c = 149.760 Mb/s
- OC-12c = 599.040 Mb/s
- OC-48c = 2.3961 Gb/s
- OC-192c = 9.5846 Gb/s

Chapter 4

Circuit-Switching Networks

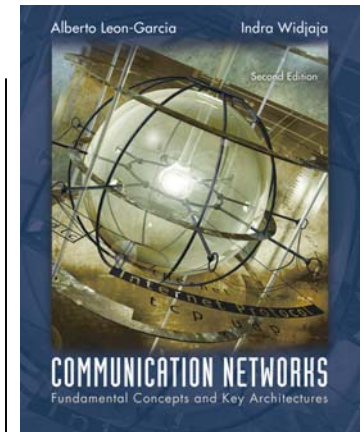

Transport Networks

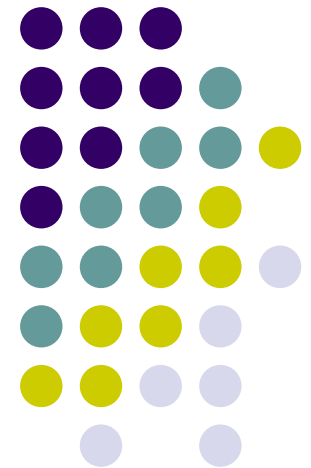

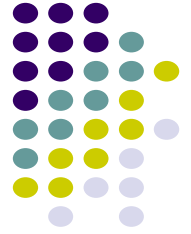

Transport Networks

- Backbone of modern networks
- Provide high-speed connections: Typically STS-1 up to OC-192
- Clients: large routers, telephone switches, regional networks
- Very high reliability required because of consequences of failure
 - 1 STS-1 = 783 voice calls; 1 OC-48 = 32000 voice calls;

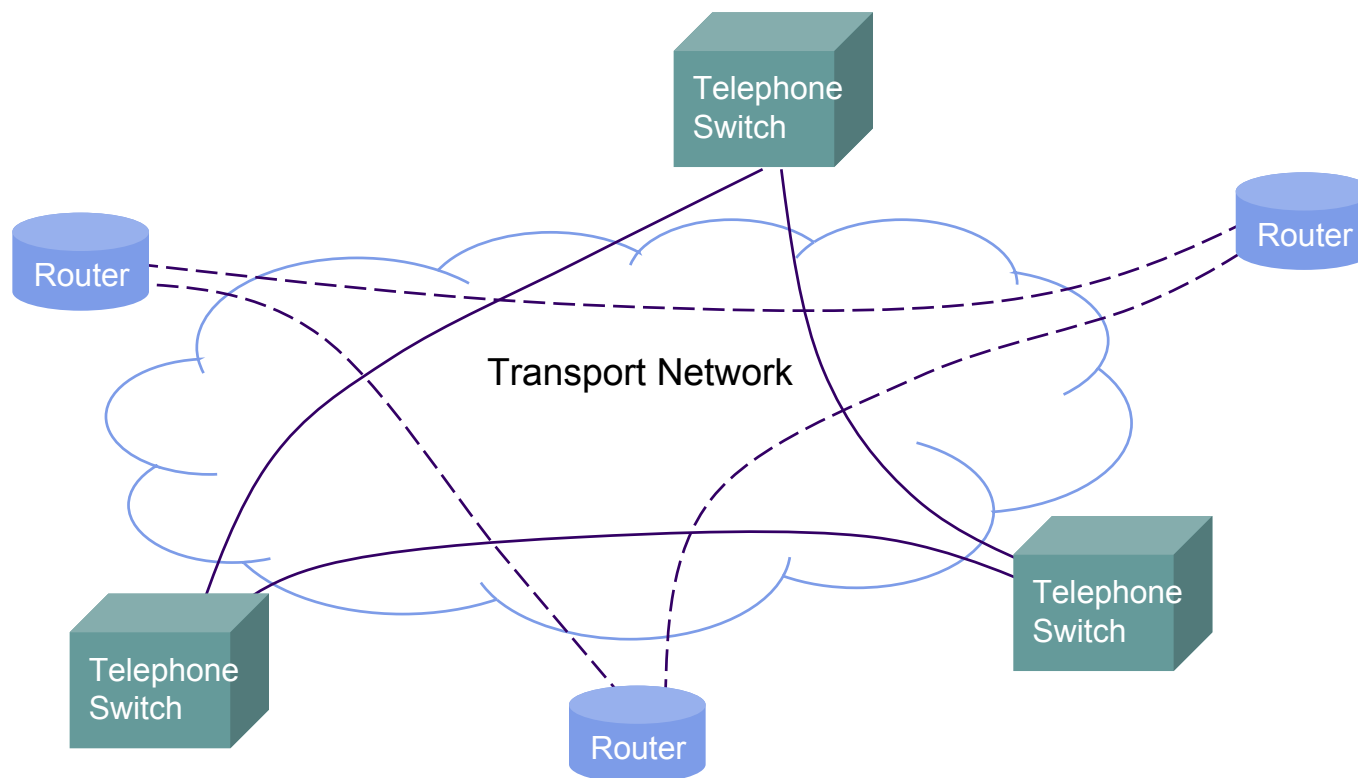

SONET ADM Networks

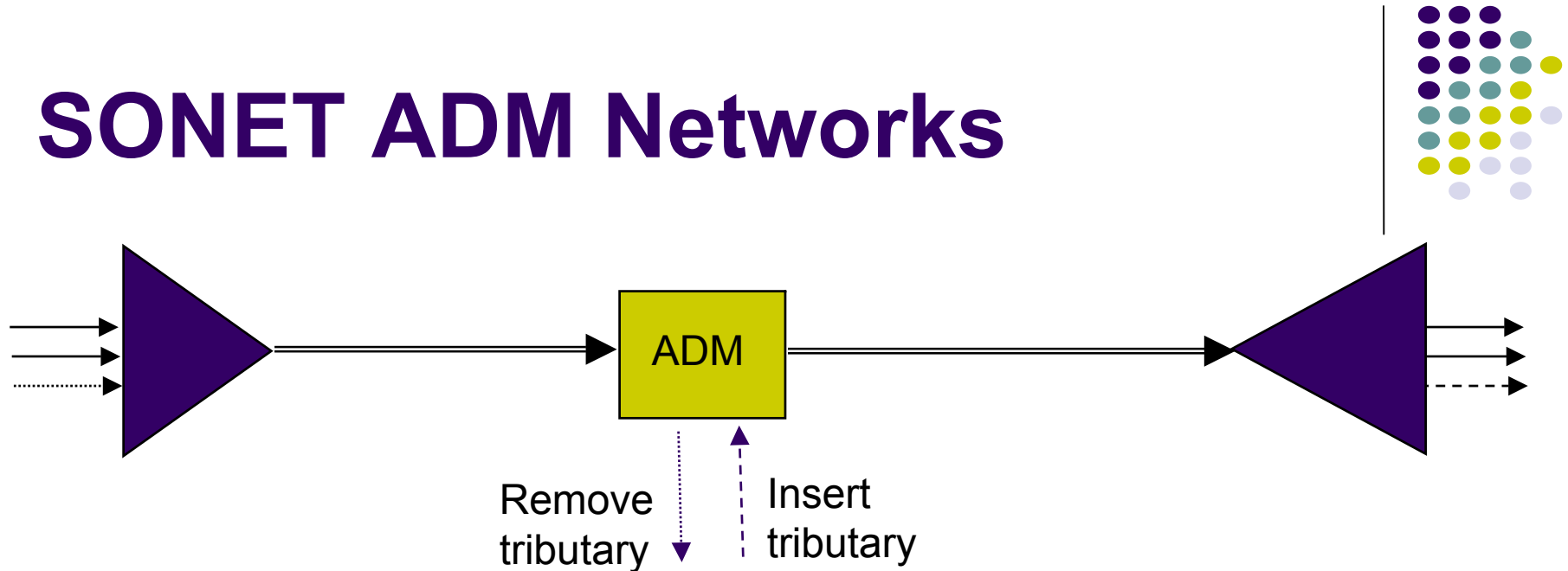

- SONET ADMs: the heart of existing transport networks
- ADMs interconnected in linear and ring topologies
- SONET signaling enables fast restoration (within 50 ms) of transport connections



Linear ADM Topology

- ADMs connected in linear fashion
- Tributaries inserted and dropped to connect clients

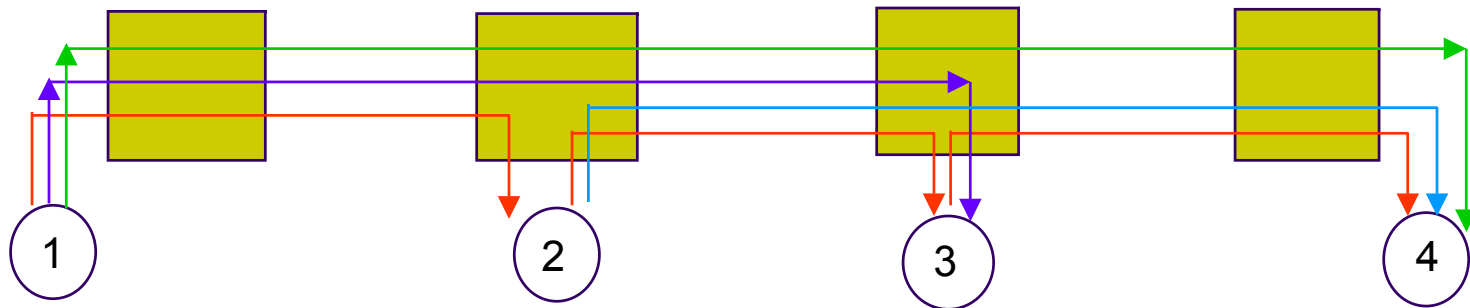

- Tributaries traverse ADMs transparently
- Connections create a *logical* topology seen by clients
- Tributaries from right to left are not shown

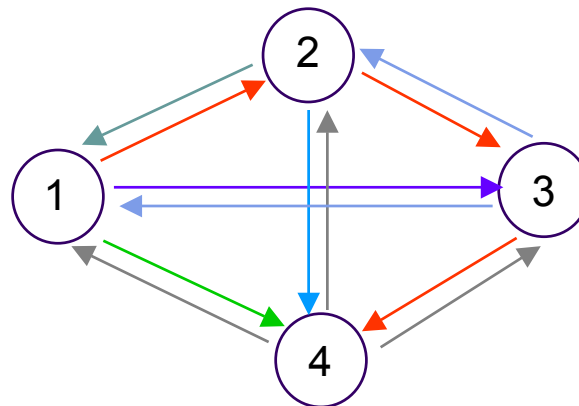

1+1 Linear Automatic Protection Switching

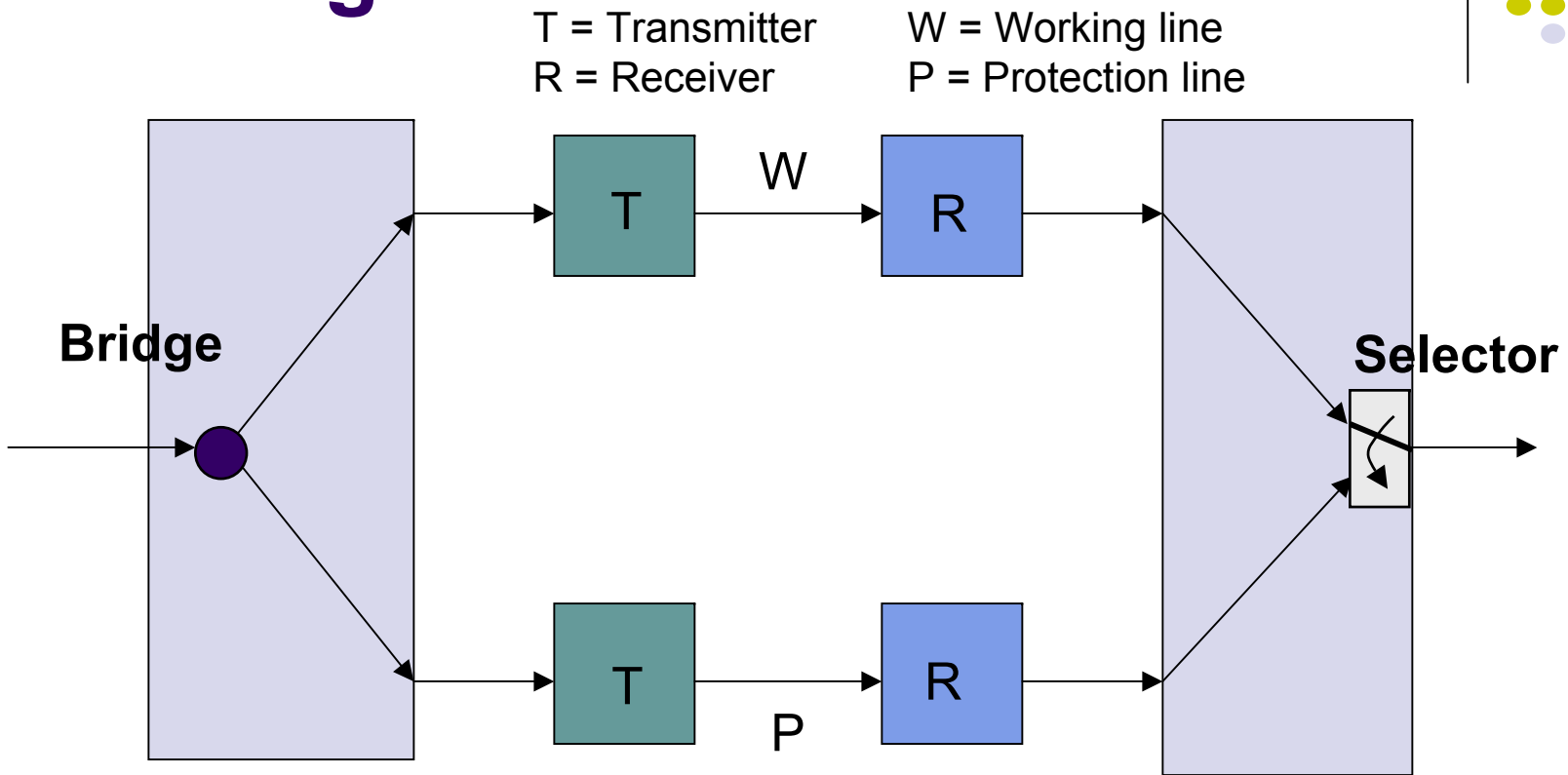

- Simultaneous transmission over diverse routes
- Monitoring of signal quality
- Fast switching in response to signal degradation
- 100% redundant bandwidth



1:1 Linear APS

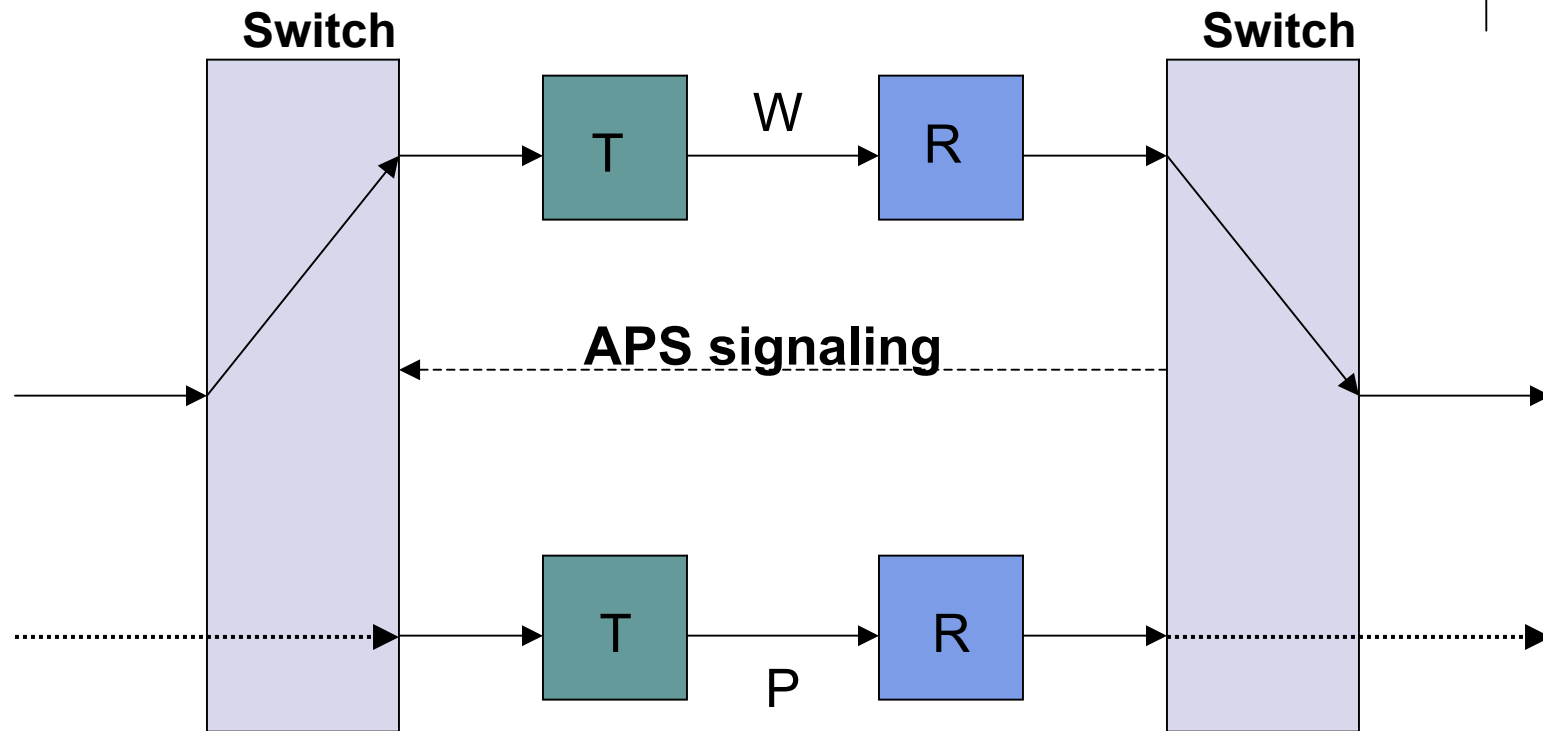

- Transmission on working fiber
- Signal for switch to protection route in response to signal degradation
- Can carry extra (preemptible traffic) on protection line

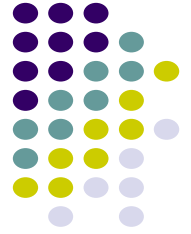

1:N Linear APS

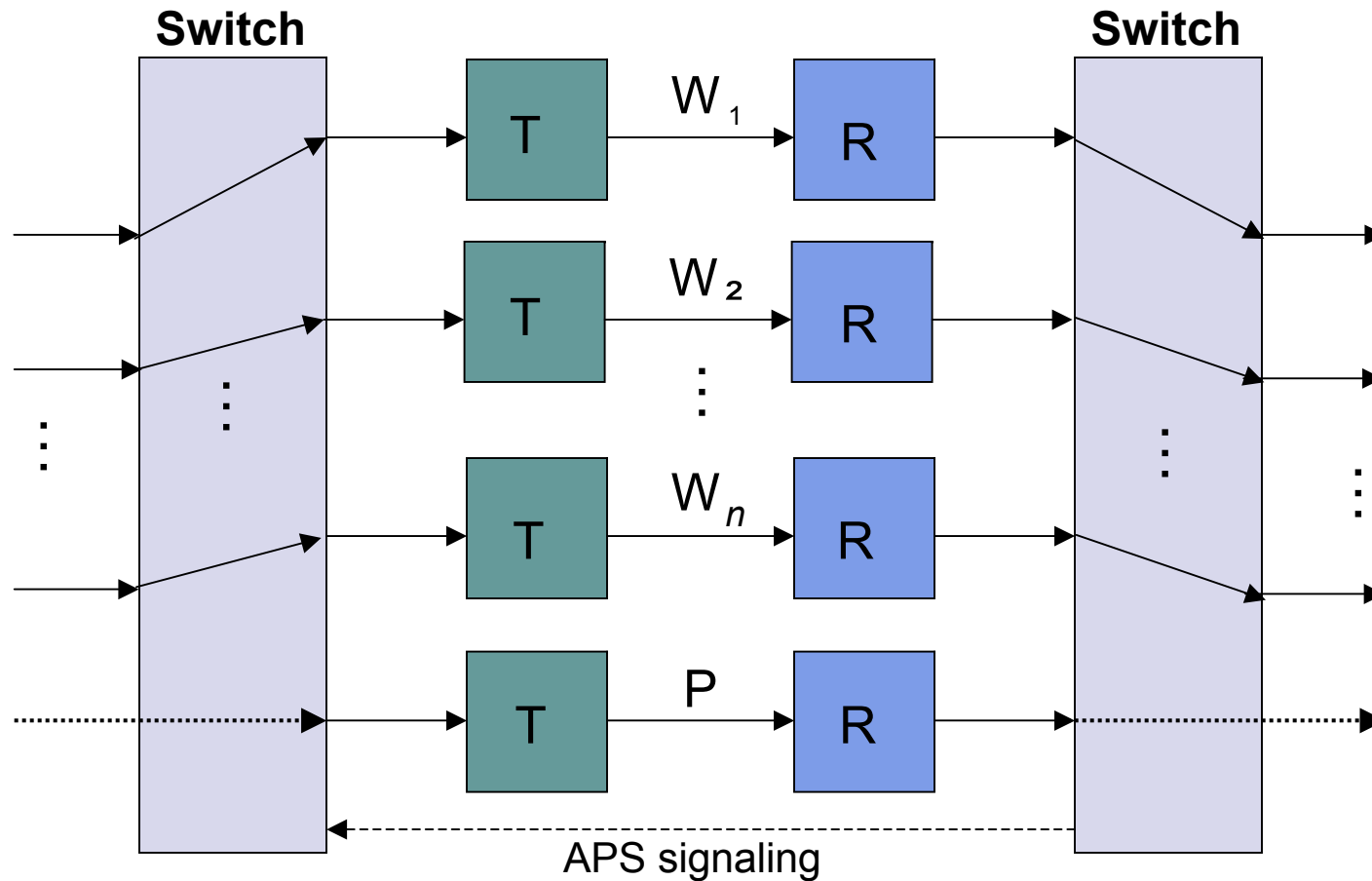

- Transmission on diverse routes; protect for 1 fault
- Reverts to original working channel after repair
- More bandwidth efficient

SONET Rings

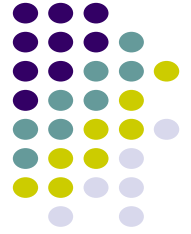

- ADMs can be connected in ring topology
- Clients see *logical* topology created by tributaries

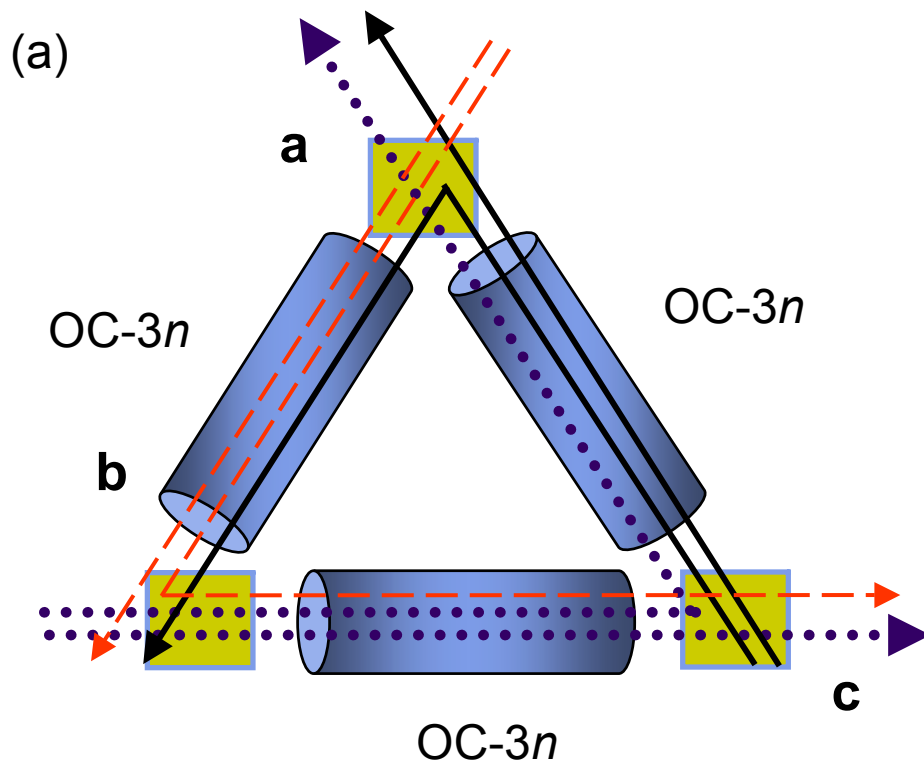

Three ADMs connected in physical ring topology

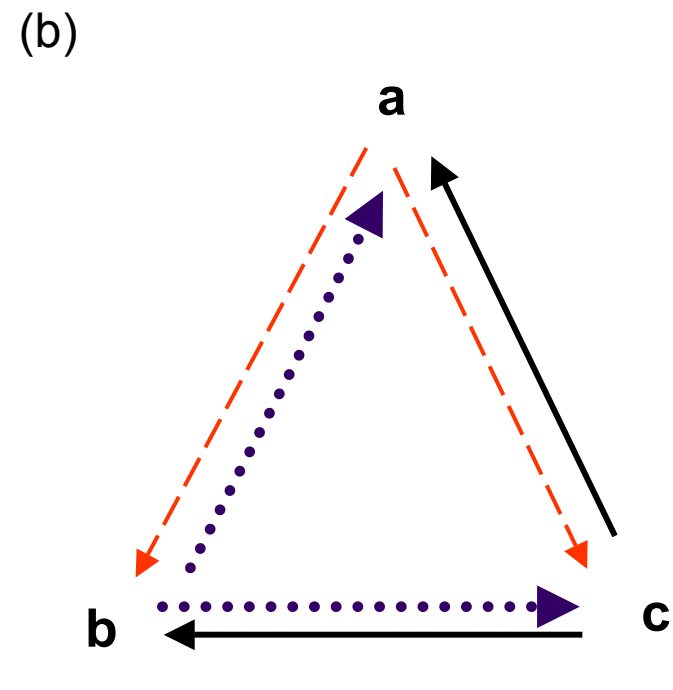

Logical fully connected topology

SONET Ring Options

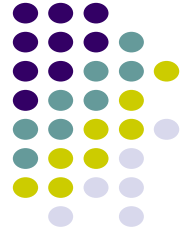

- 2 vs. 4 Fiber Ring Network
- Unidirectional vs. bidirectional transmission
- Path vs. Link protection

- Spatial capacity re-use & bandwidth efficiency
- Signalling requirements

Two-Fiber Unidirectional Path Switched Ring

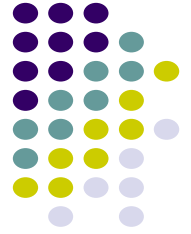

Two fibers transmit in opposite directions

- Unidirectional
 - Working traffic flows clockwise
 - Protection traffic flows counter-clockwise
 - 1+1 like
- Selector at receiver does *path protection switching*

UPSR

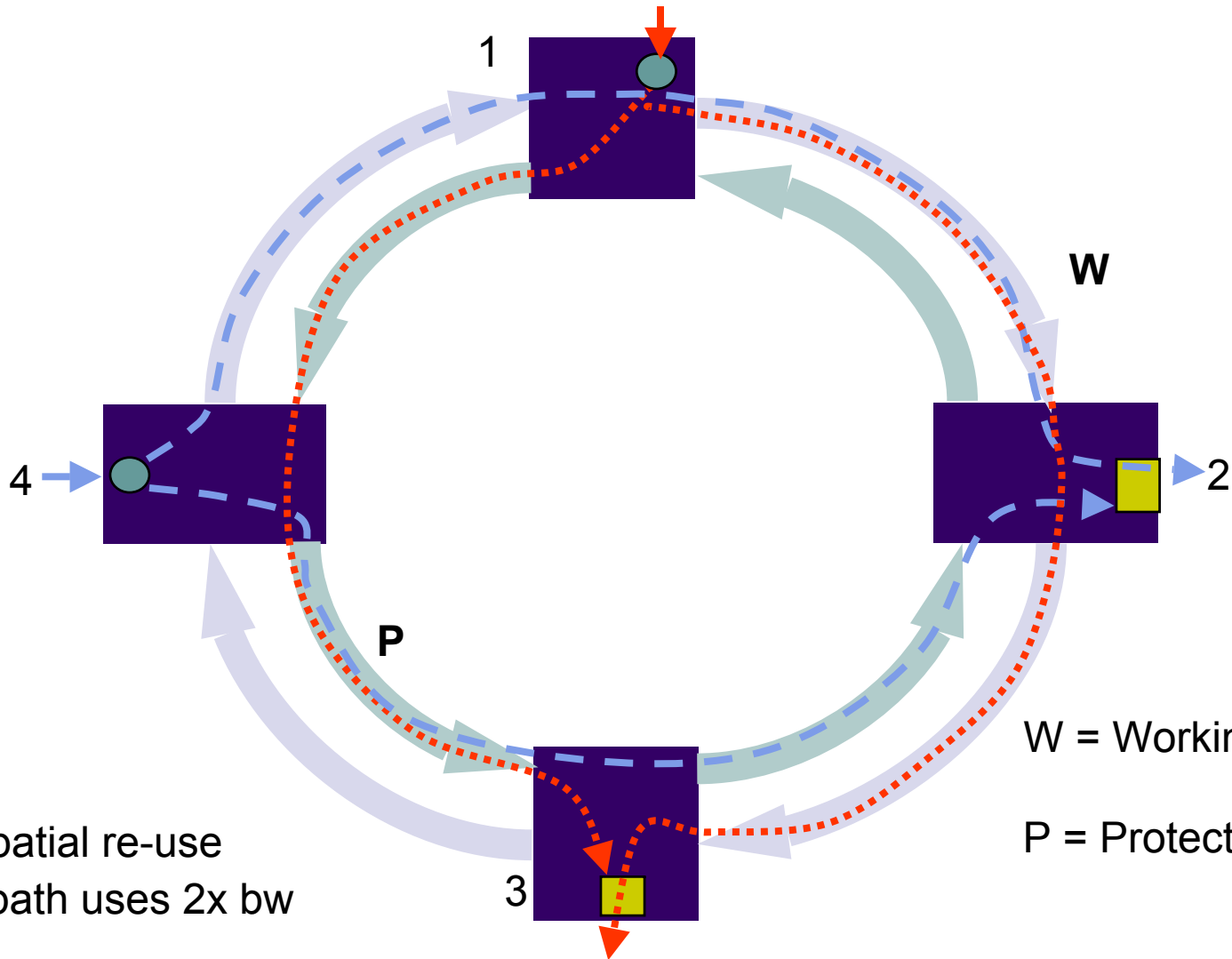
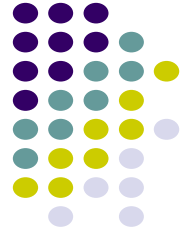

No spatial re-use
Each path uses 2x bw

UPSR path recovery

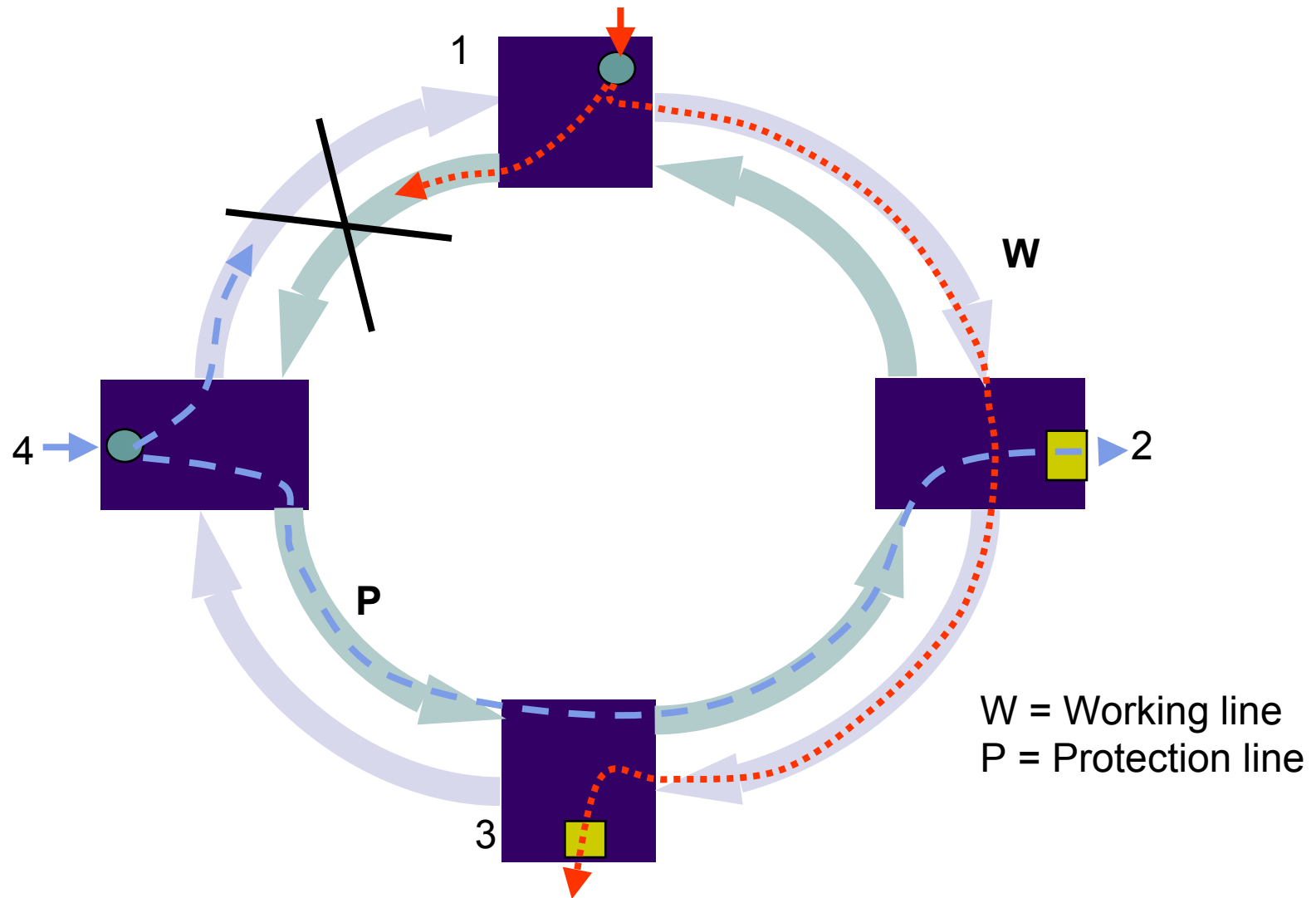

UPSR Properties



- Low complexity
- Fast path protection
- 2 TX, 2 RX
- No spatial re-use; ok for hub traffic pattern
- Suitable for lower-speed access networks
- Different delay between W and P path

Four-Fiber Bidirectional Line Switched Ring



- 1 working fiber pair; 1 protection fiber pair
- Bidirectional
 - Working traffic & protection traffic use *same route* in working pair
 - 1:N like
- *Line* restoration provided by either:
 - Restoring a failed span
 - Switching the line around the ring

4-BLSR

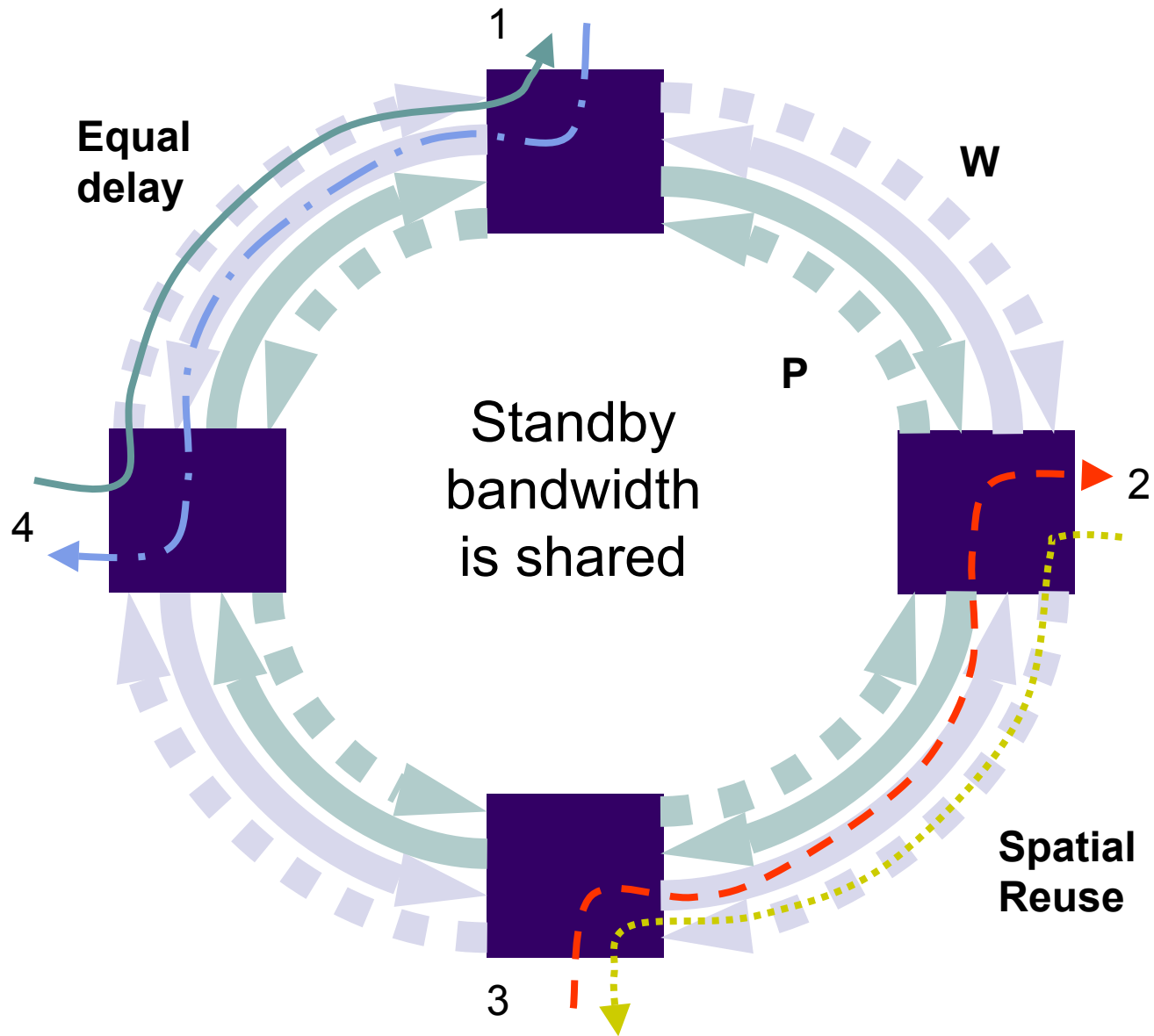
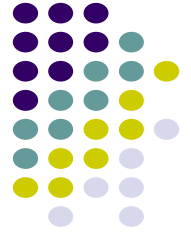

BLSR Span Switching

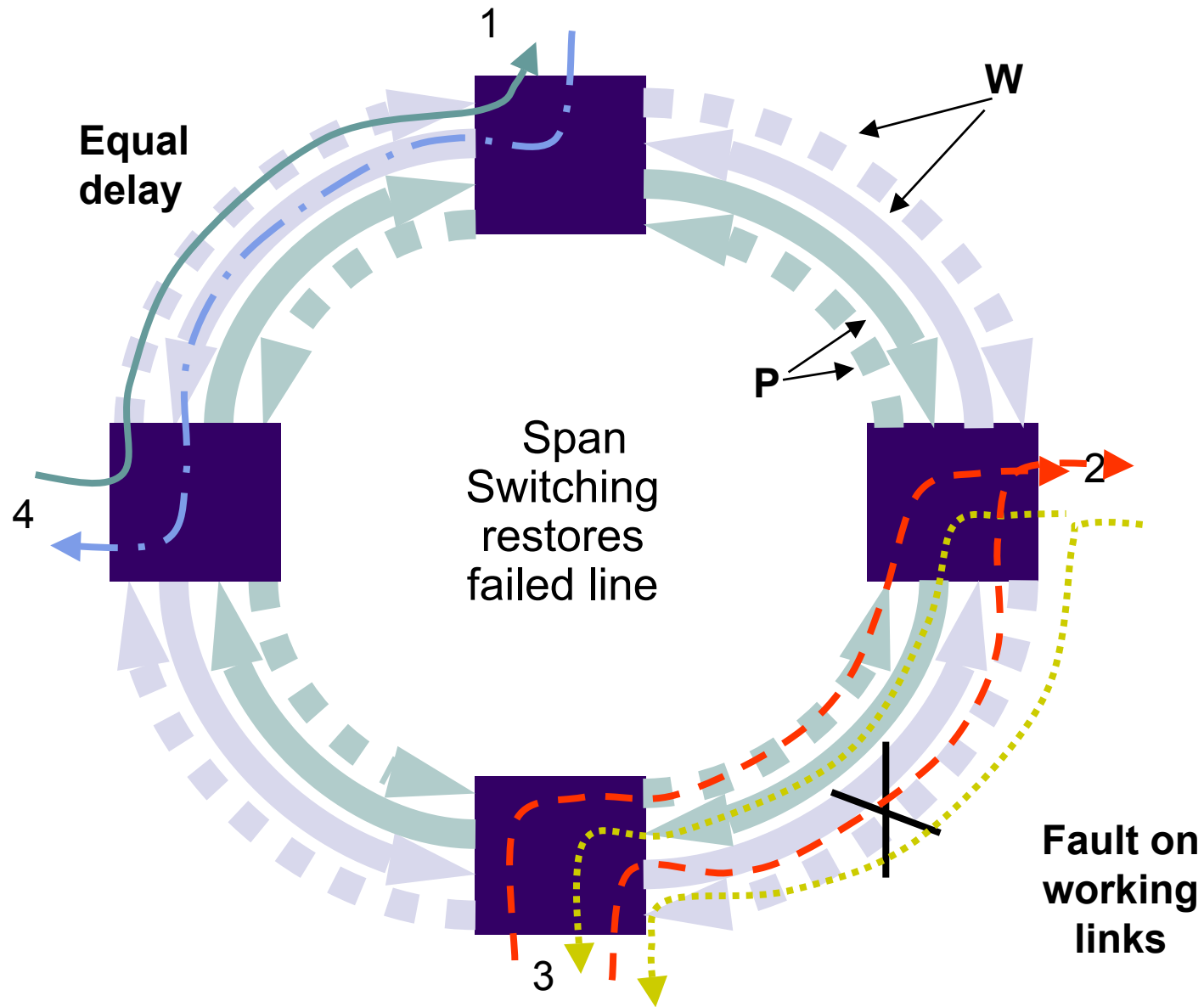

BLSR Span Switching

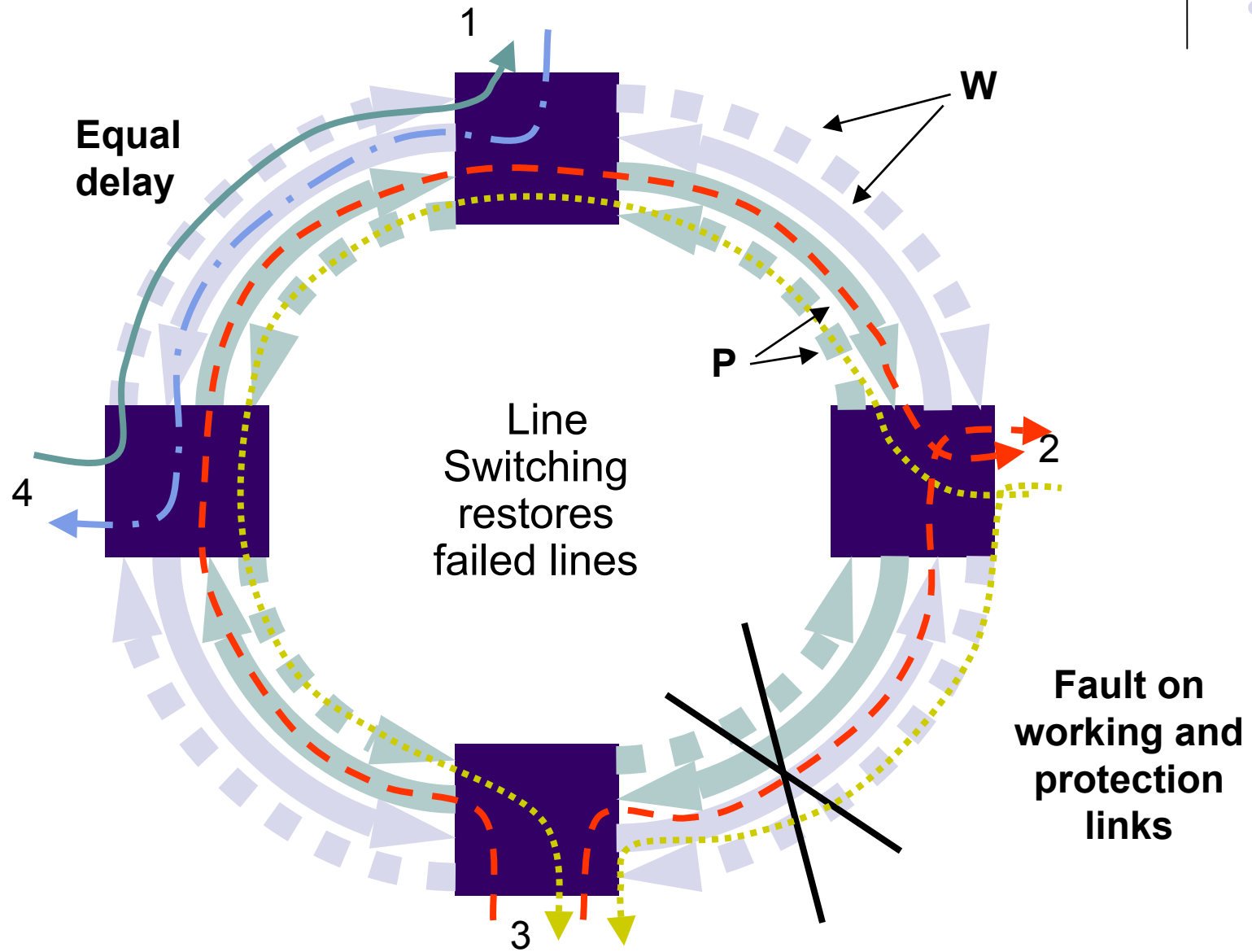
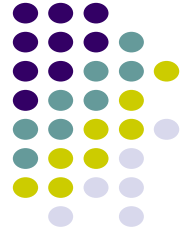

4-BLSR Properties

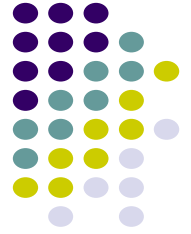

- High complexity: signalling required
- Fast line protection for restricted distance (1200 km) and number of nodes (16)
- 4 TX, 4 RX
- Spatial re-use; higher bandwidth efficiency
- Good for uniform traffic pattern
- Suitable for high-speed backbone networks
- Multiple simultaneous faults can be handled

Backbone Networks consist of Interconnected Rings

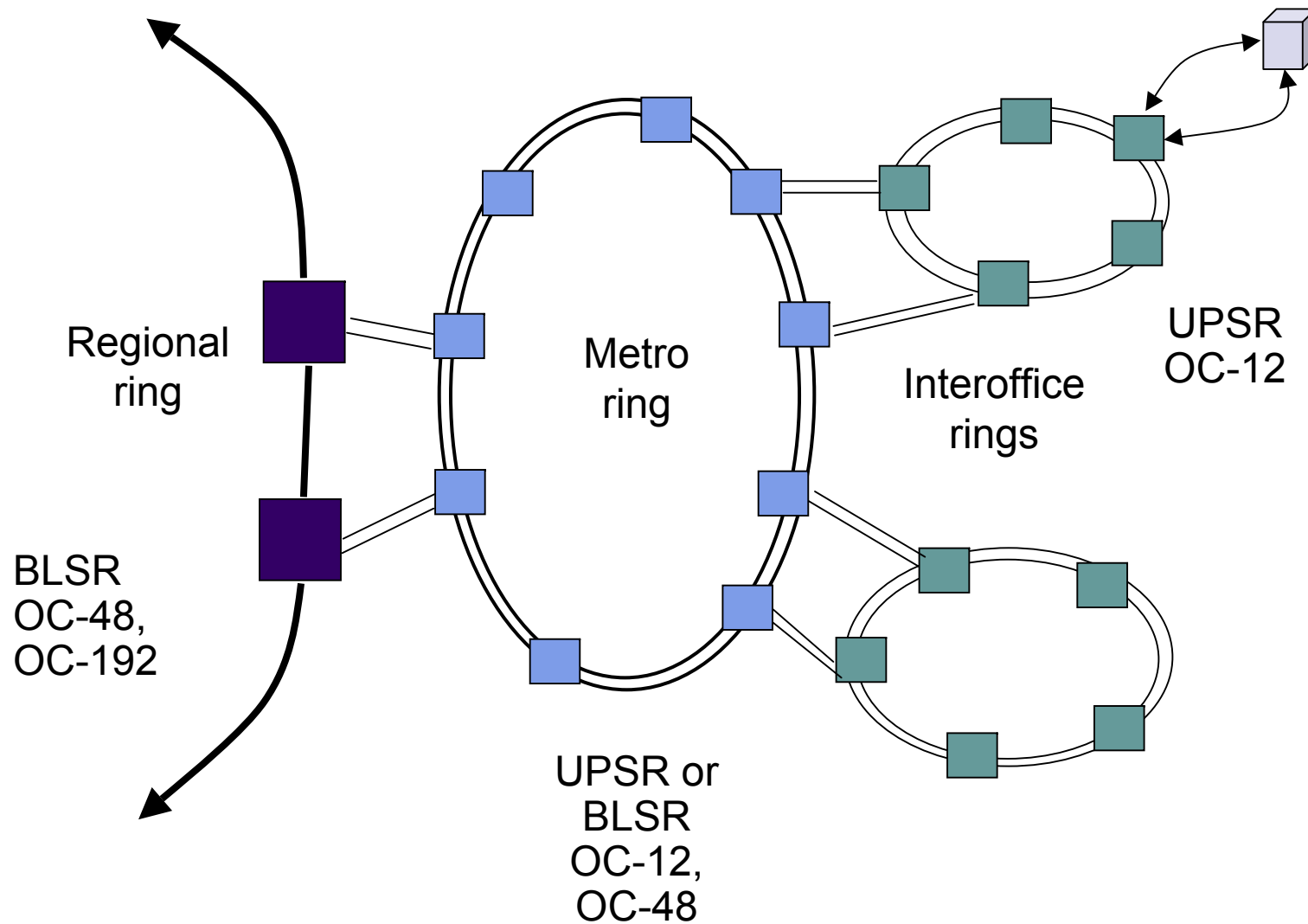

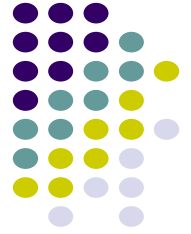

The Problem with Rings

- Managing bandwidth can be complex
- Increasing transmission rate in one span affects all equipment in the ring
- Introducing WDM means stacking SONET ADMs to build parallel rings
- Distance limitations on ring size implies many rings need to be traversed in long distance
- End-to-end protection requires ring-interconnection mechanisms

Managing 1 ring is simple; Managing many rings is very complex

Mesh Topology Networks using SONET Cross-Connects

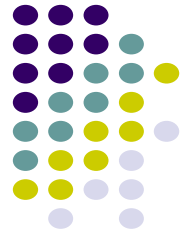

- Cross-Connects are nxn switches
- Interconnects SONET streams
- More flexible and efficient than rings
- Need mesh protection & restoration

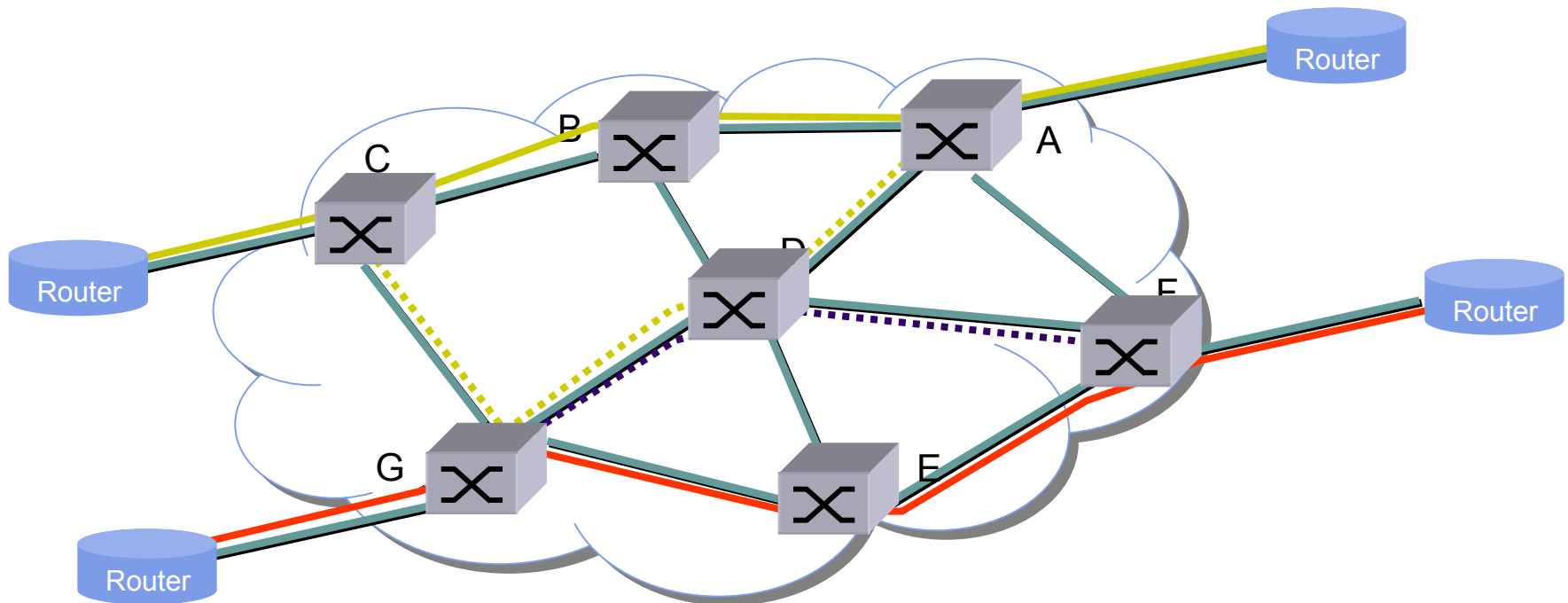

From SONET to WDM

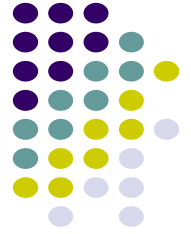

SONET

- combines multiple SPEs into high speed digital stream
- ADMs and crossconnects interconnected to form networks
- SPE paths between clients from logical topology
- High reliability through protection switching

WDM

- combines multiple wavelengths into a common fiber
- Optical ADMs can be built to insert and drop wavelengths in same manner as in SONET ADMS
- Optical crossconnects can also be built
- All-optical backbone networks will provide end-to-end wavelength connections
- Protection schemes for recovering from failures are being developed to provide high reliability in all-optical networks

Optical Switching

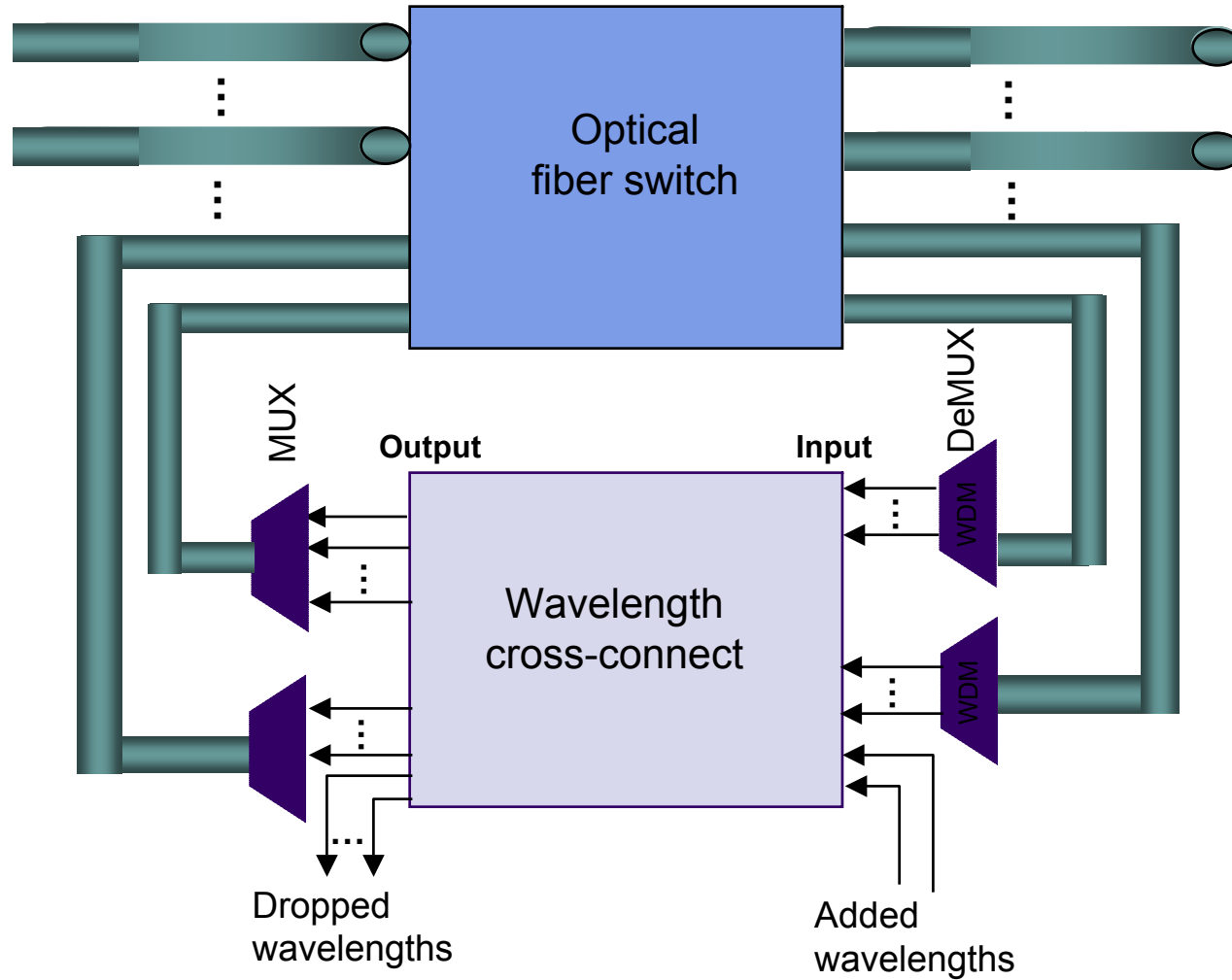

Chapter 4

Circuit-Switching Networks

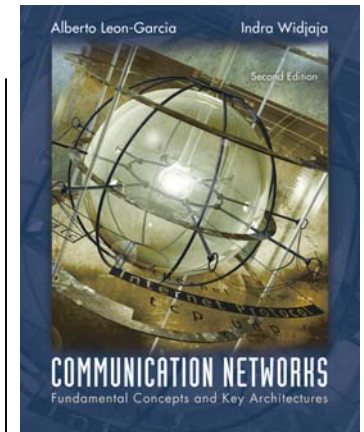

Circuit Switches

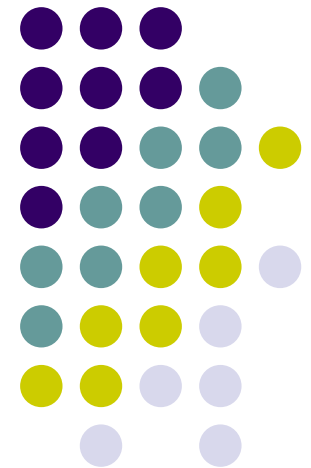

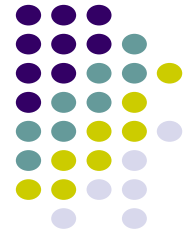

Network: Links & switches

- Circuit consists of dedicated resources in sequence of links & switches across network
- *Circuit switch* connects input links to output links

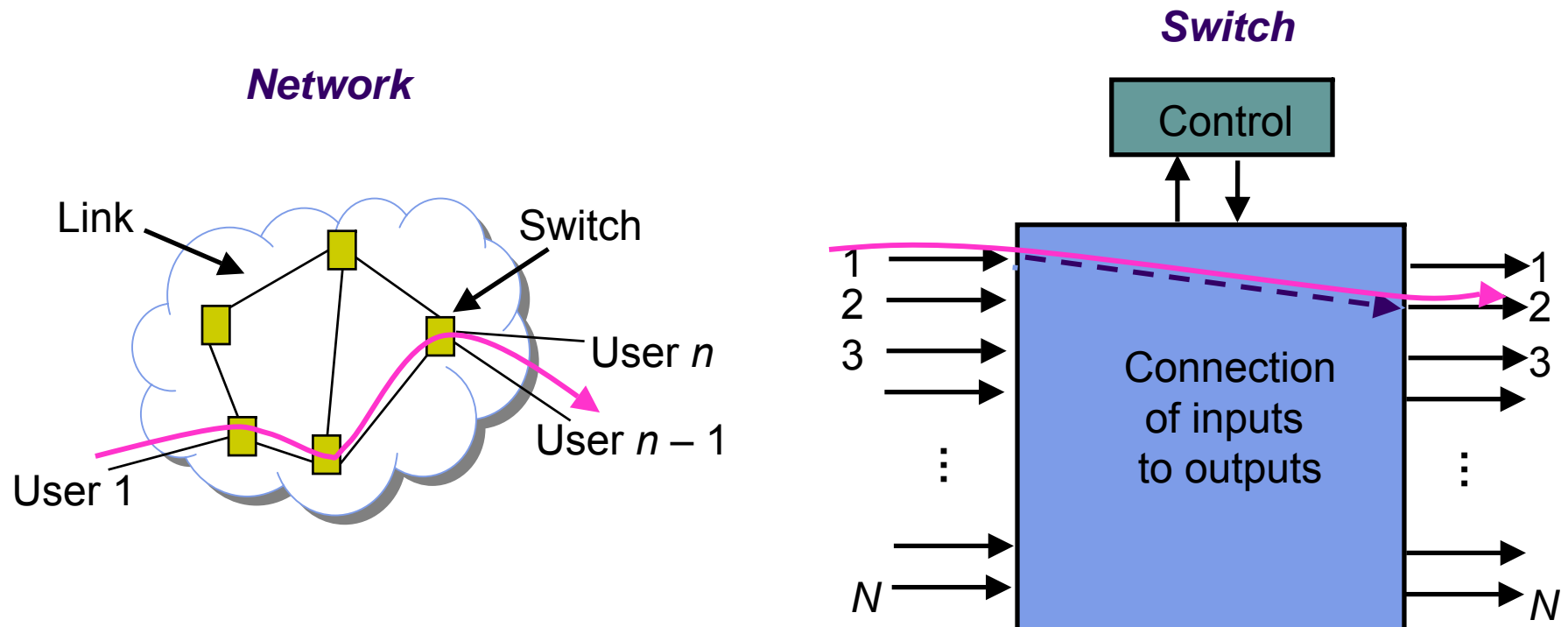

Circuit Switch Types

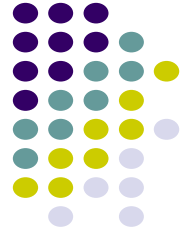

- Space-Division switches
 - Provide separate physical connection between inputs and outputs
 - Crossbar switches
 - Multistage switches
- Time-Division switches
 - Time-slot interchange technique
 - Time-space-time switches
- Hybrids combine Time & Space switching

Crossbar Space Switch



- $N \times N$ array of crosspoints
- Connect an input to an output by closing a crosspoint
- Nonblocking: Any input can connect to idle output
- Complexity: N^2 crosspoints

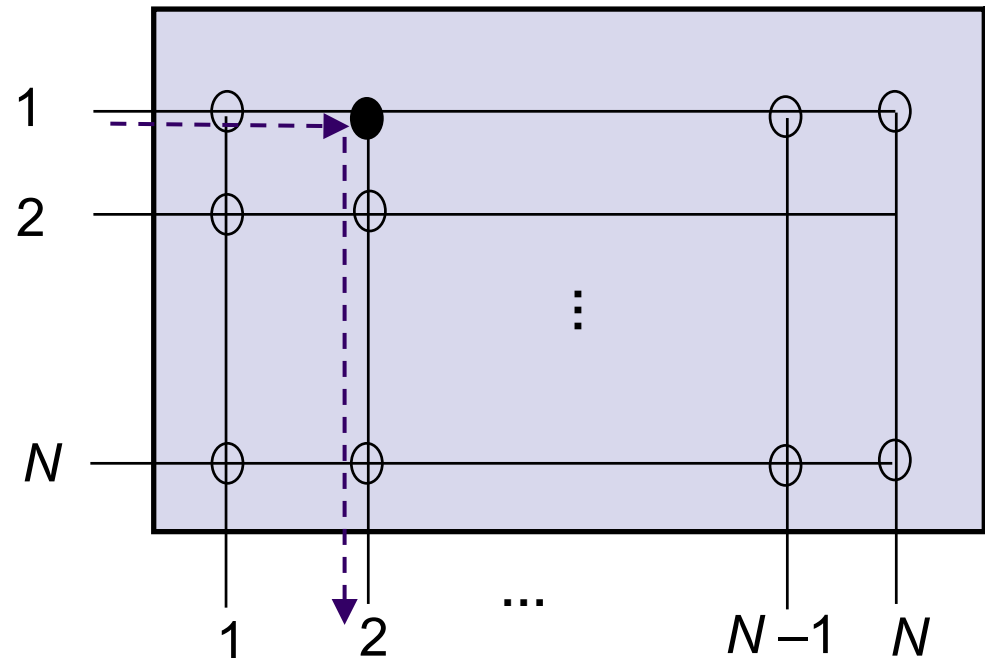



Multistage Space Switch

- Large switch built from multiple stages of small switches
- The n inputs to a first-stage switch share k paths through intermediate crossbar switches
- Larger k (more intermediate switches) means more paths to output
- In 1950s, Clos asked, “How many intermediate switches required to make switch nonblocking?”

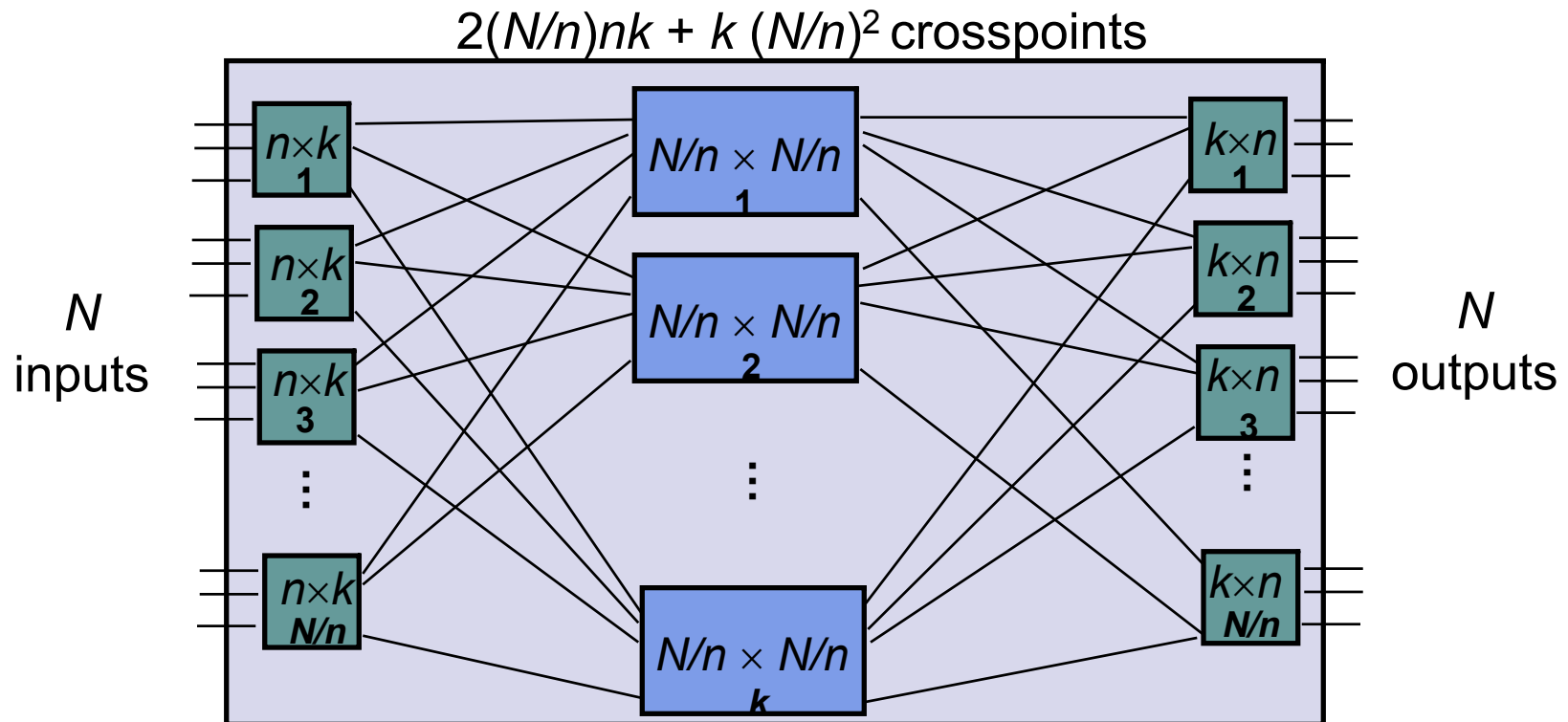

Clos Non-Blocking Condition:

$$k=2n-1$$



- Request connection from last input to input switch j to last output in output switch m
- Worst Case: All other inputs have seized top $n-1$ middle switches AND all other outputs have seized next $n-1$ middle switches
- If $k=2n-1$, there is another path left to connect desired input to desired output

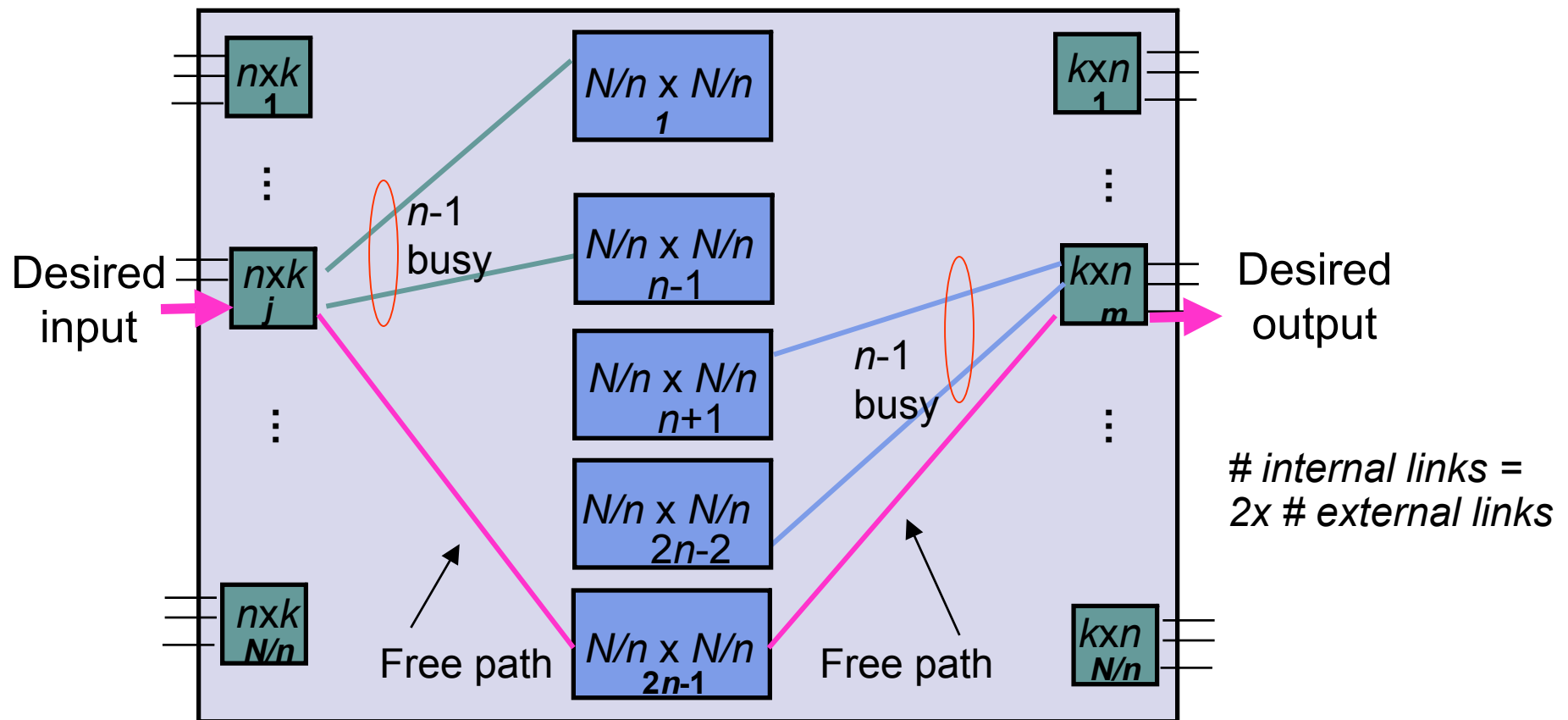

Minimum Complexity Clos Switch

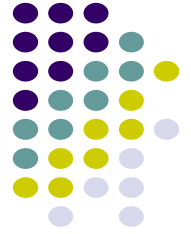

$C(n)$ = number of crosspoints in Clos switch

$$= 2Nk + k\left(\frac{N}{n}\right)^2 = 2N(2n - 1) + (2n - 1)\left(\frac{N}{n}\right)^2$$

Differentiate with respect to n :

$$0 = \frac{\delta C}{\delta n} = 4N - \frac{2N^2}{n^2} + \frac{2N^2}{n^3} \approx 4N - \frac{2N^2}{n^2} \implies n \approx \sqrt{\frac{N}{2}}$$

The minimized number of crosspoints is then:

$$C^* = \left(2N + \frac{N^2}{N/2}\right) \left(2\left(\frac{N}{2}\right)^{1/2} - 1\right) \approx 4N \sqrt{2N} = 4 \sqrt{2N^{1.5}}$$

This is lower than N^2 for large N

Example: Clos Switch Design



- Circa 2002, Mindspeed offered a Crossbar chip with the following specs:
 - 144 inputs x 144 outputs, 3.125 Gbps/line
 - Aggregate Crossbar chip throughput: 450 Gbps
- Clos Nonblocking Design for 1152x1152 switch
 - $N=1152$, $n=8$, $k=16$
 - $N/n=144$ 8x16 switches in first stage
 - 16 144x144 in centre stage
 - 144 16x8 in third stage
 - Aggregate Throughput: 3.6 Tbps!
- Note: the 144x144 crossbar can be partitioned into multiple smaller switches

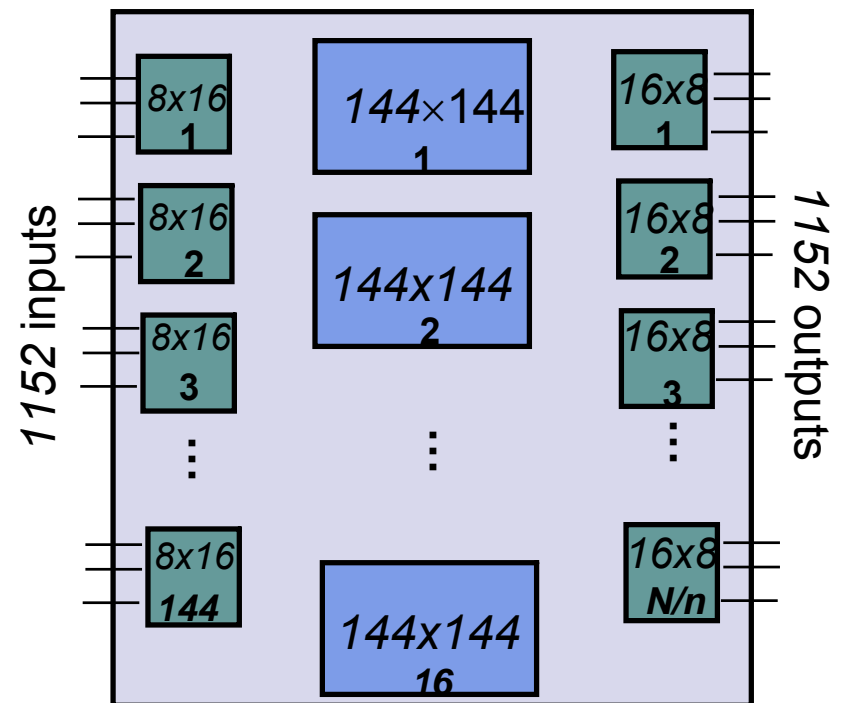

Time-Slot Interchange (TSI) Switching



- Write bytes from arriving TDM stream into memory
- Read bytes in permuted order into outgoing TDM stream
- Max # slots = $125 \mu\text{sec} / (2 \times \text{memory cycle time})$

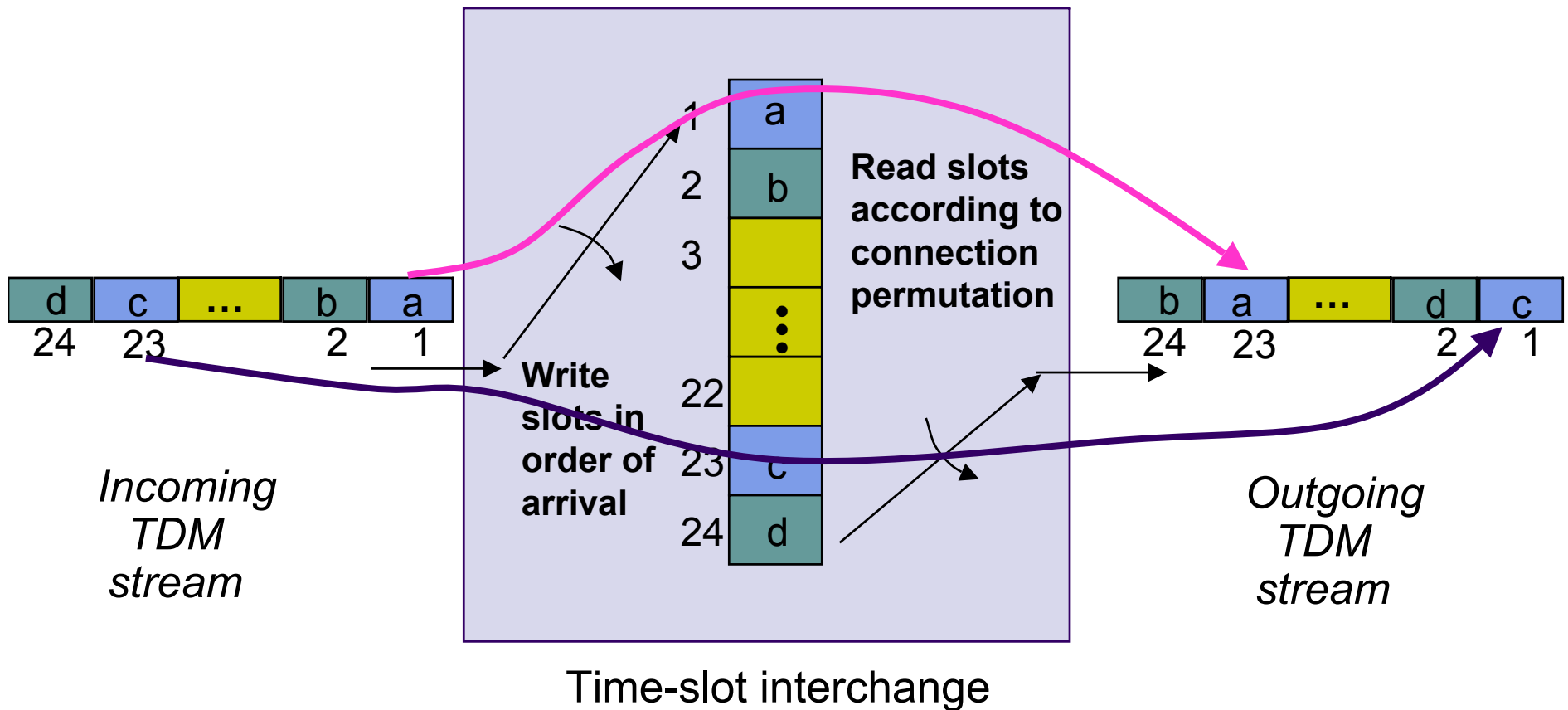



Time-Space-Time Hybrid Switch

- Use TSI in first & third stage; Use crossbar in middle
- Replace n input \times k output space switch by TSI switch that takes n -slot input frame and switches it to k -slot output frame

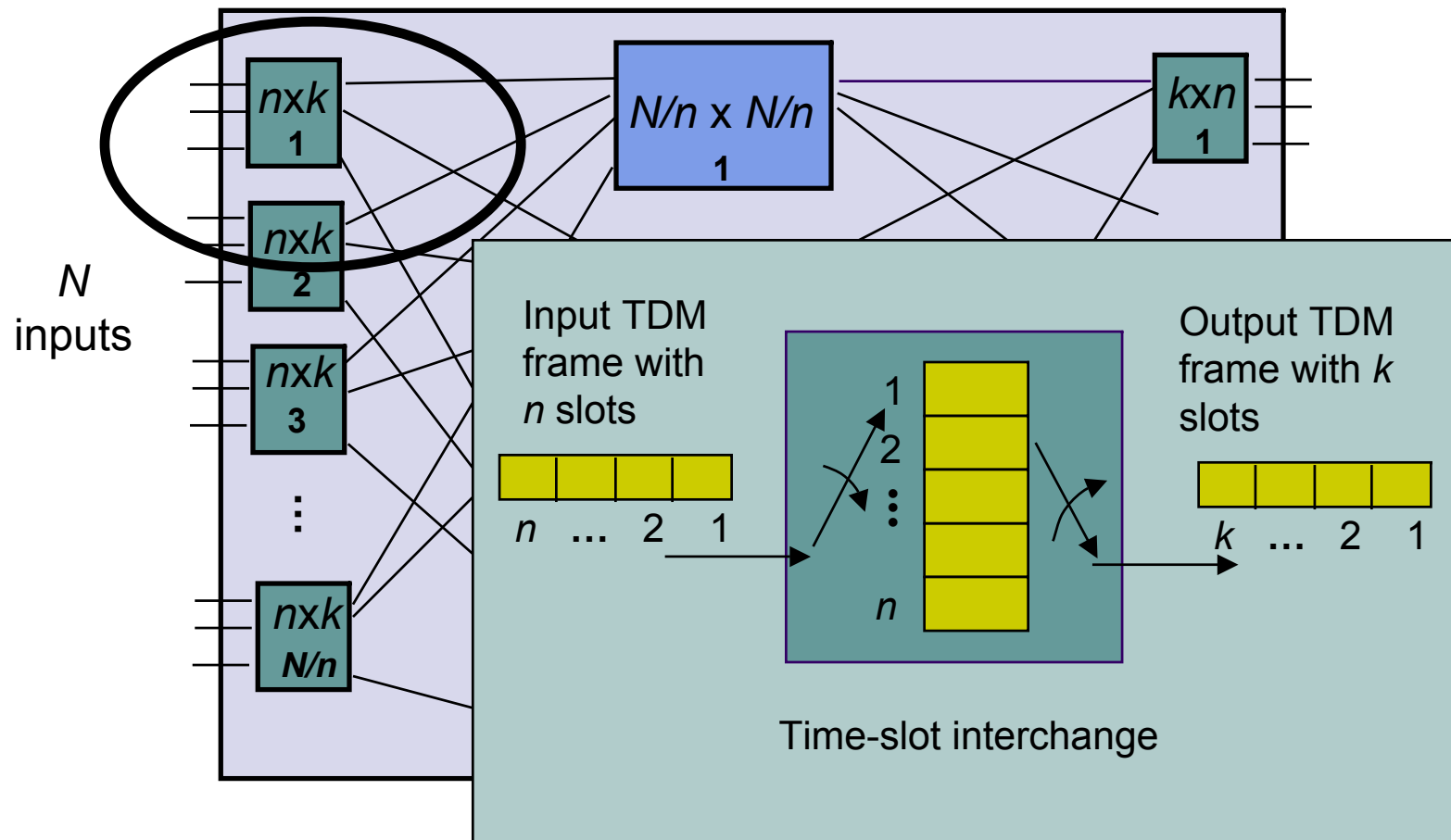

Flow of time slots between switches

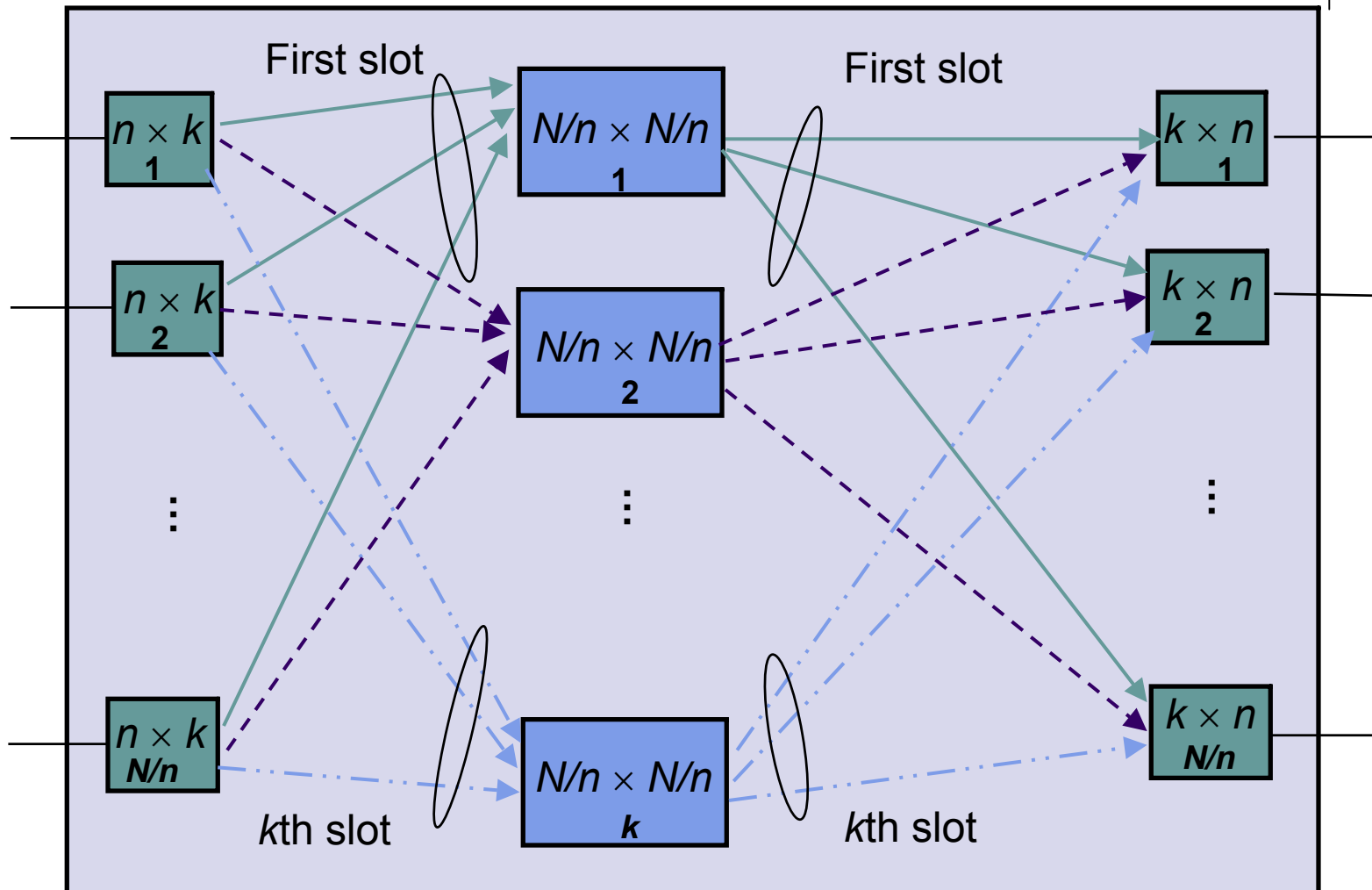

- Only one space switch active in each time slot

Time-Share the Crossbar Switch

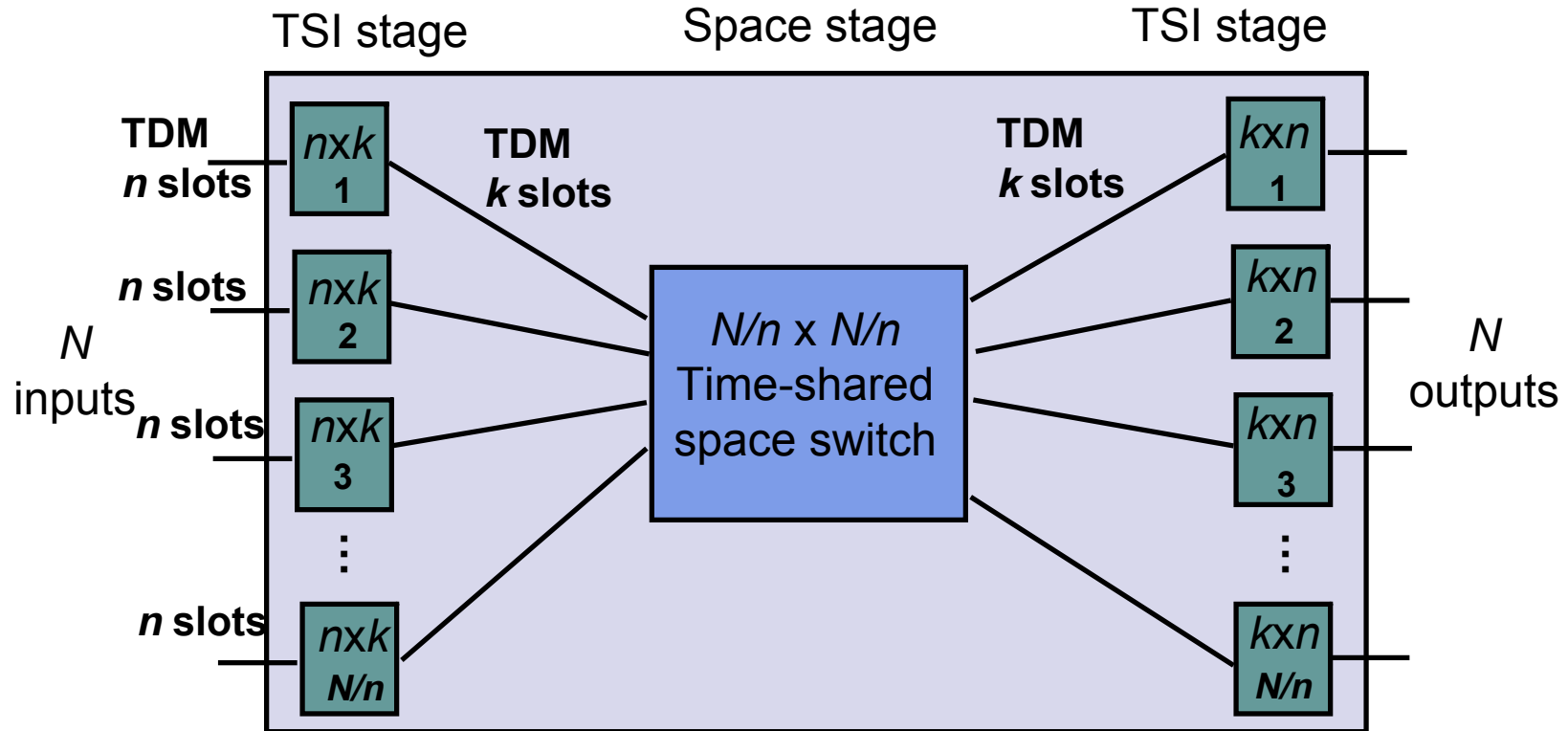

- Interconnection pattern of space switch is reconfigured every time slot
- Very compact design: fewer lines because of TDM & less space because of time-shared crossbar

Example: $A \rightarrow 3$, $B \rightarrow 4$, $C \rightarrow 1$, $D \rightarrow 3$

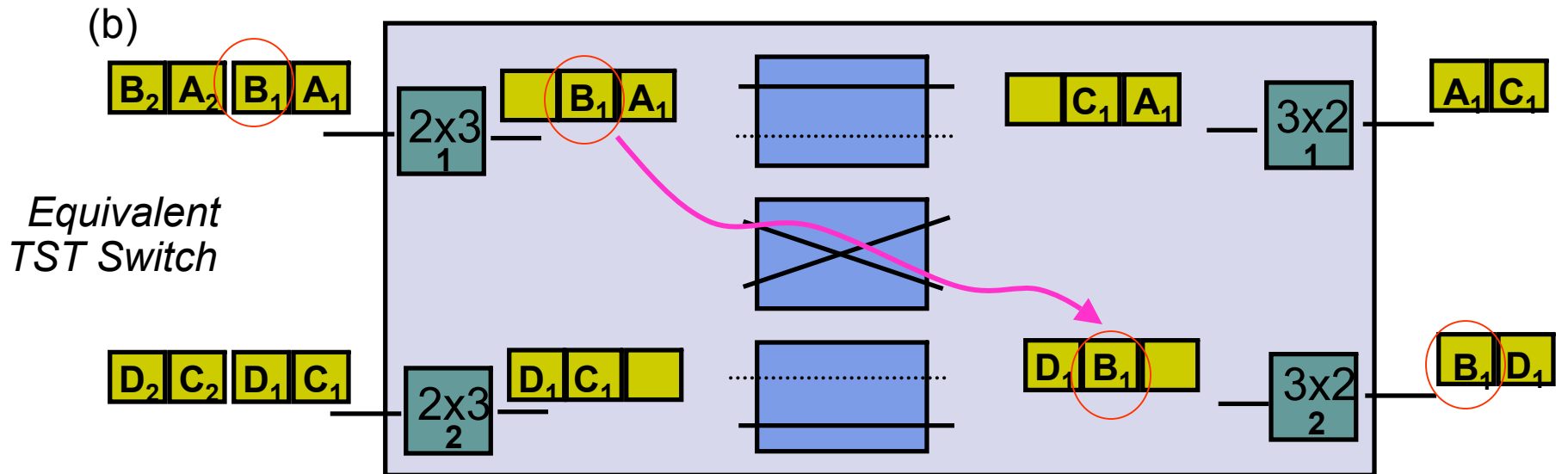
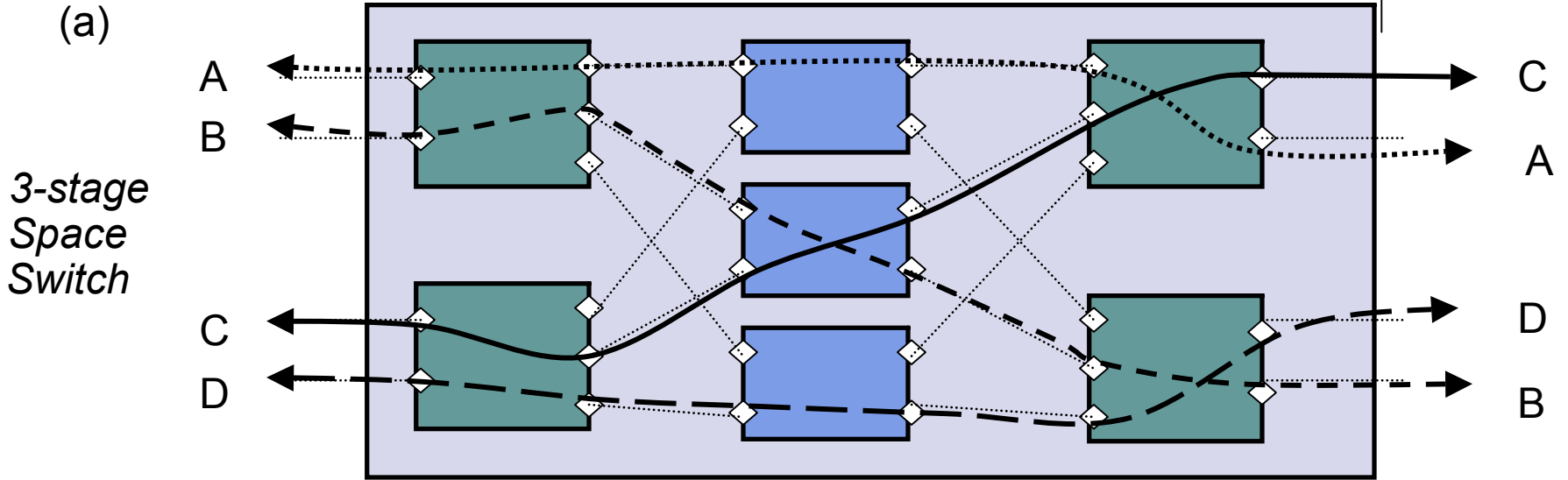
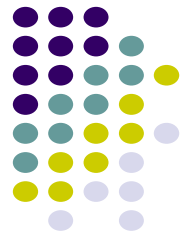

Example: T-S-T Switch Design



For $N = 960$

- Single stage space switch ~ 1 million crosspoints
- T-S-T
 - Let $n = 120$ $N/n = 8$ TSIs
 - $k = 2n - 1 = 239$ for non-blocking
 - Pick $k = 240$ time slots
 - Need 8×8 time-multiplexed space switch

For $N = 96,000$

- T-S-T
 - Let $n = 120$ $k = 239$
 - $N / n = 800$
 - Need 800×800 space switch

Available TSI Chips circa 2002



- OC-192 SONET Framing Chips
 - Decompose 192 STS1s and perform (restricted) TSI
- Single-chip TST
 - 64 inputs x 64 outputs
 - Each line @ STS-12 (622 Mbps)
 - Equivalent to 768x768 STS-1 switch

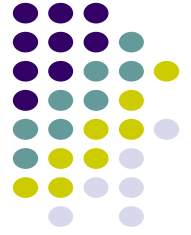

Pure Optical Switching

- Pure Optical switching: light-in, light-out, without optical-to-electronic conversion
- Space switching theory can be used to design optical switches
 - Multistage designs using small optical switches
 - Typically 2x2 or 4x4
 - MEMs and Electro-optic switching devices
- Wavelength switches
 - Very interesting designs when space switching is combined with wavelength conversion devices

Chapter 4

Circuit-Switching Networks

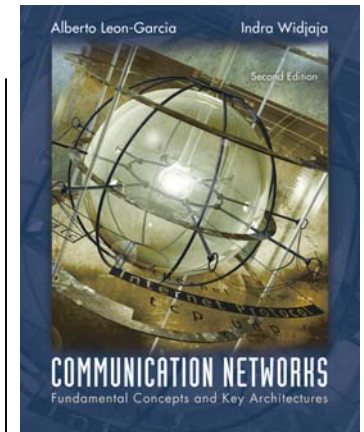

The Telephone Network

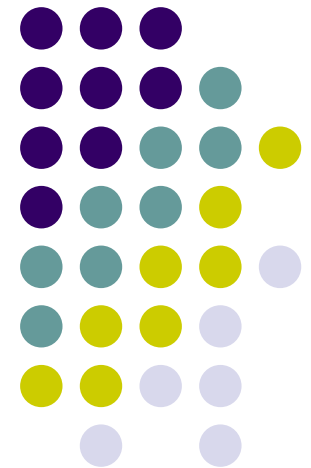

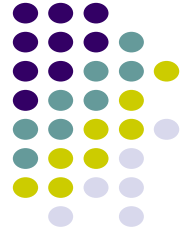

Telephone Call

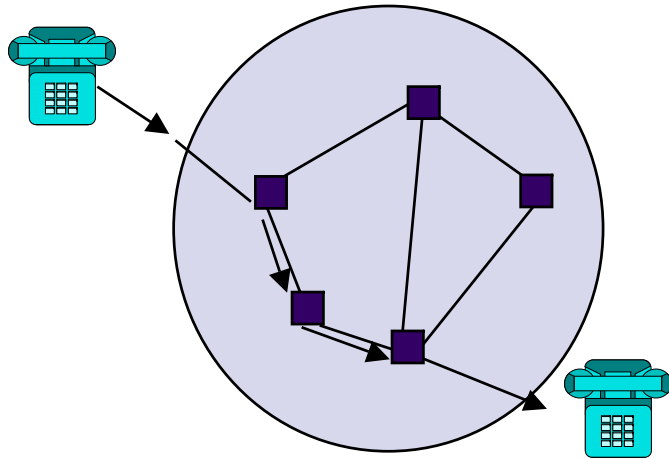

- User requests connection
- Network signaling establishes connection
- Speakers converse
- User(s) hang up
- Network releases connection resources

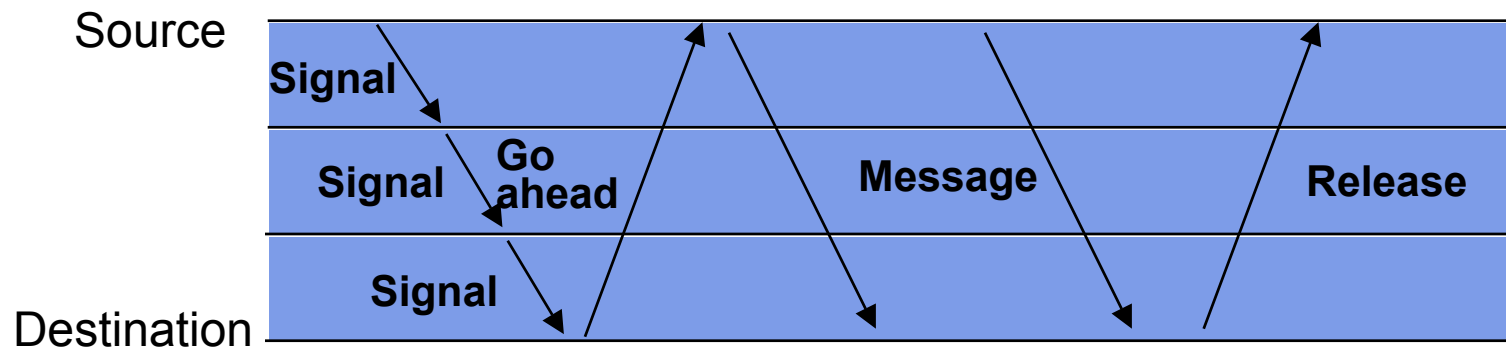

Call Routing

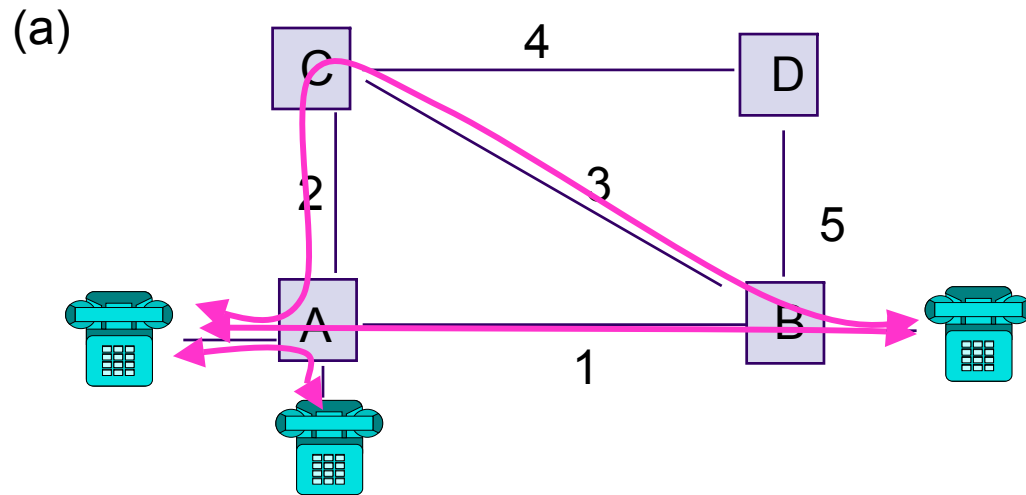
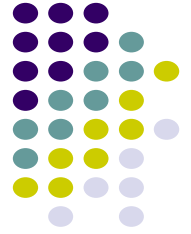

- Local calls routed through local network (In U.S. Local Access & Transport Area)
- Long distance calls routed to long distance service provider

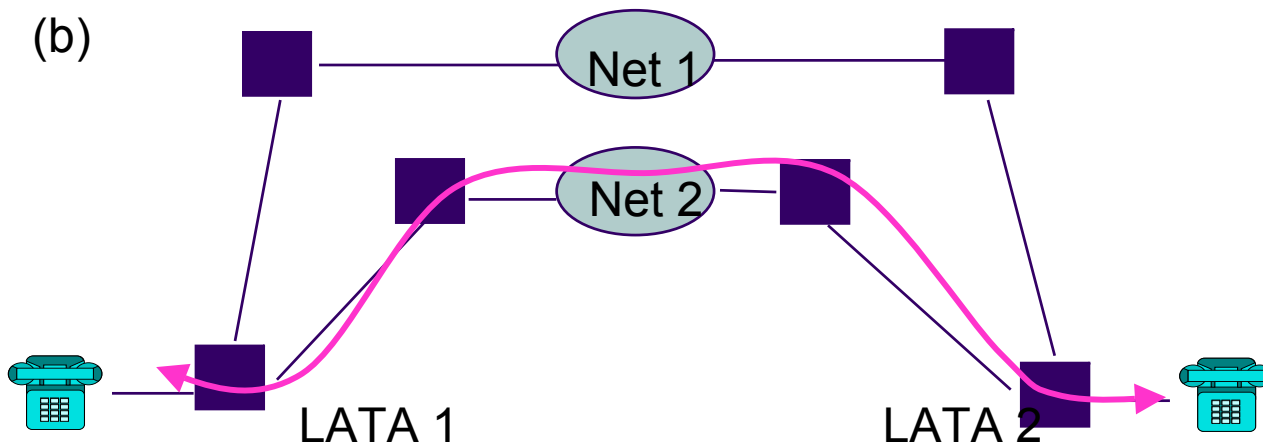

Telephone Local Loop

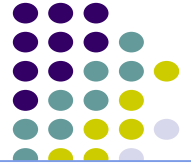

Local Loop: “Last Mile”

- Copper pair from telephone to CO
- Pedestal to SAI to Main Distribution Frame (MDF)
- 2700 cable pairs in a feeder cable
- MDF connects
 - voice signal to telephone switch
 - DSL signal to routers

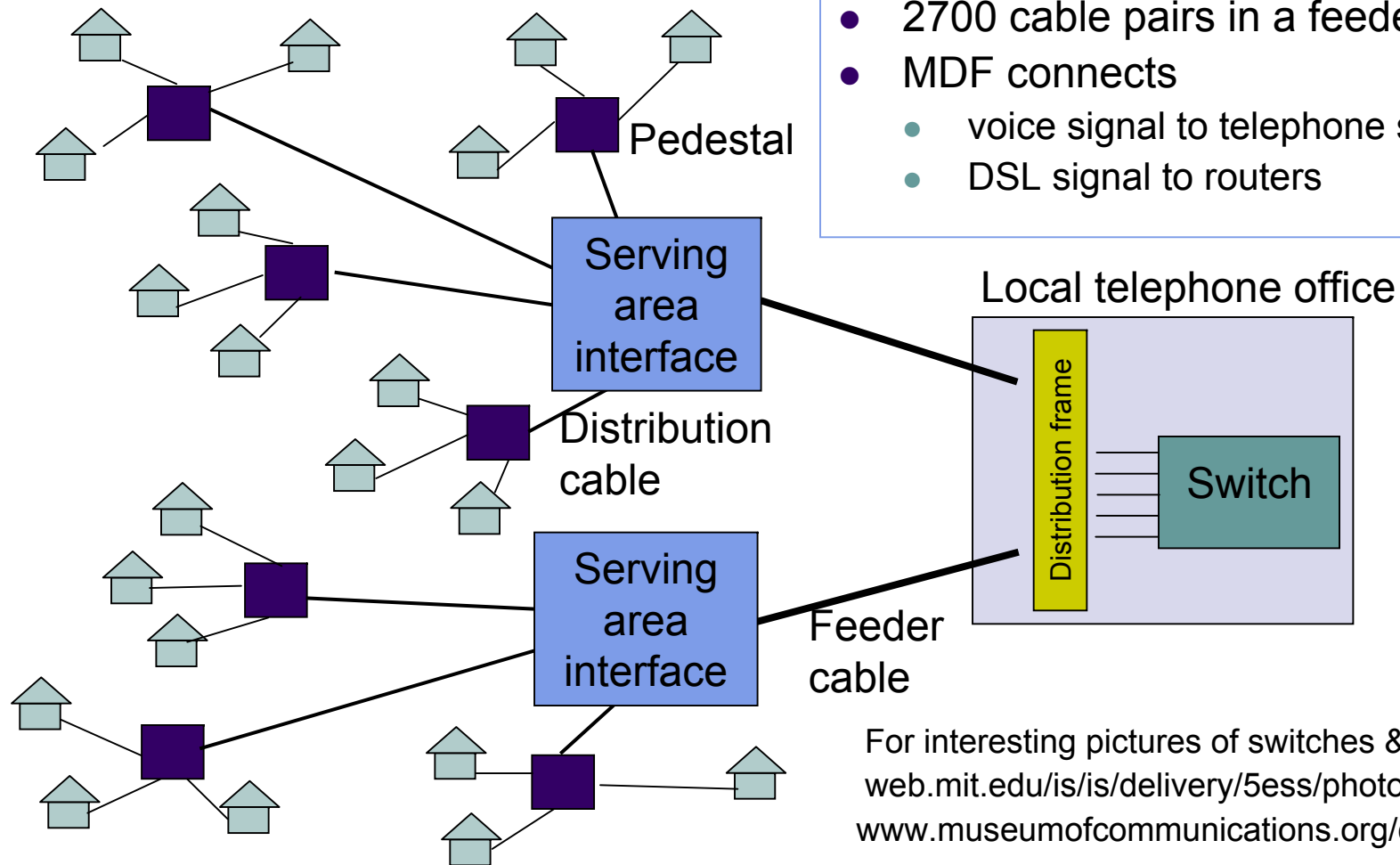

For interesting pictures of switches & MDF, see
web.mit.edu/is/is/delivery/5ess/photos.html
www.museumofcommunications.org/coe.html

Fiber-to-the-Home or Fiber-to-the-Curve?



Table 3.5 Data rates of 24-gauge twisted pair

Standard	Data Rate	Distance
T-1	1.544 Mbps	18,000 feet, 5.5 km
DS2	6.312 Mbps	12,000 feet, 3.7 km
1/4 STS-1	12.960 Mbps	4500 feet, 1.4 km
1/2 STS-1	25.920 Mbps	3000 feet, 0.9 km
STS-1	51.840 Mbps	1000 feet, 300 m

- Fiber connection to the home provides huge amount of bandwidth, but cost of optical modems still high
- Fiber to the curve (pedestal) with shorter distance from pedestal to home can provide high speeds over copper pairs

Two- & Four-wire connections



- From telephone to CO, two wires carry signals in both directions
- Inside network, 1 wire pair per direction
- Conversion from 2-wire to 4-wire occurs at hybrid transformer in the CO
- Signal reflections can occur causing speech echo
- Echo cancellers used to subtract the echo from the voice signals

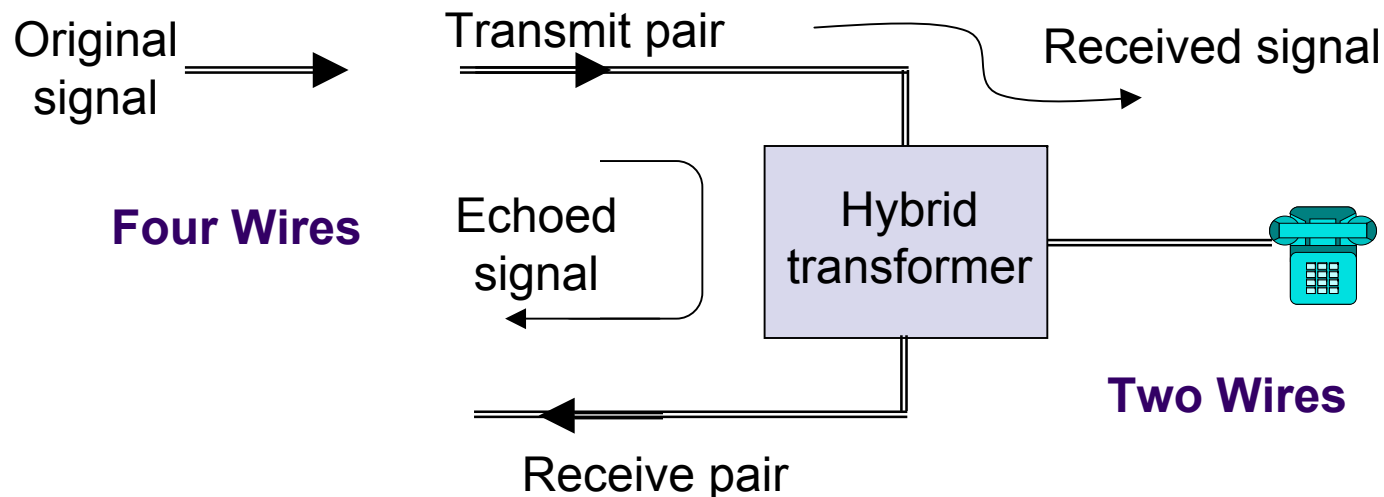

Integrated Services Digital Network (ISDN)

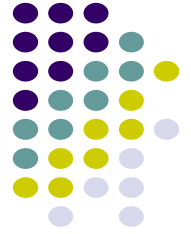

- First effort to provide end-to-end digital connections
- B channel = 64 kbps, D channel = 16 kbps
- ISDN defined interface to network
- Network consisted of separate networks for voice, data, signaling

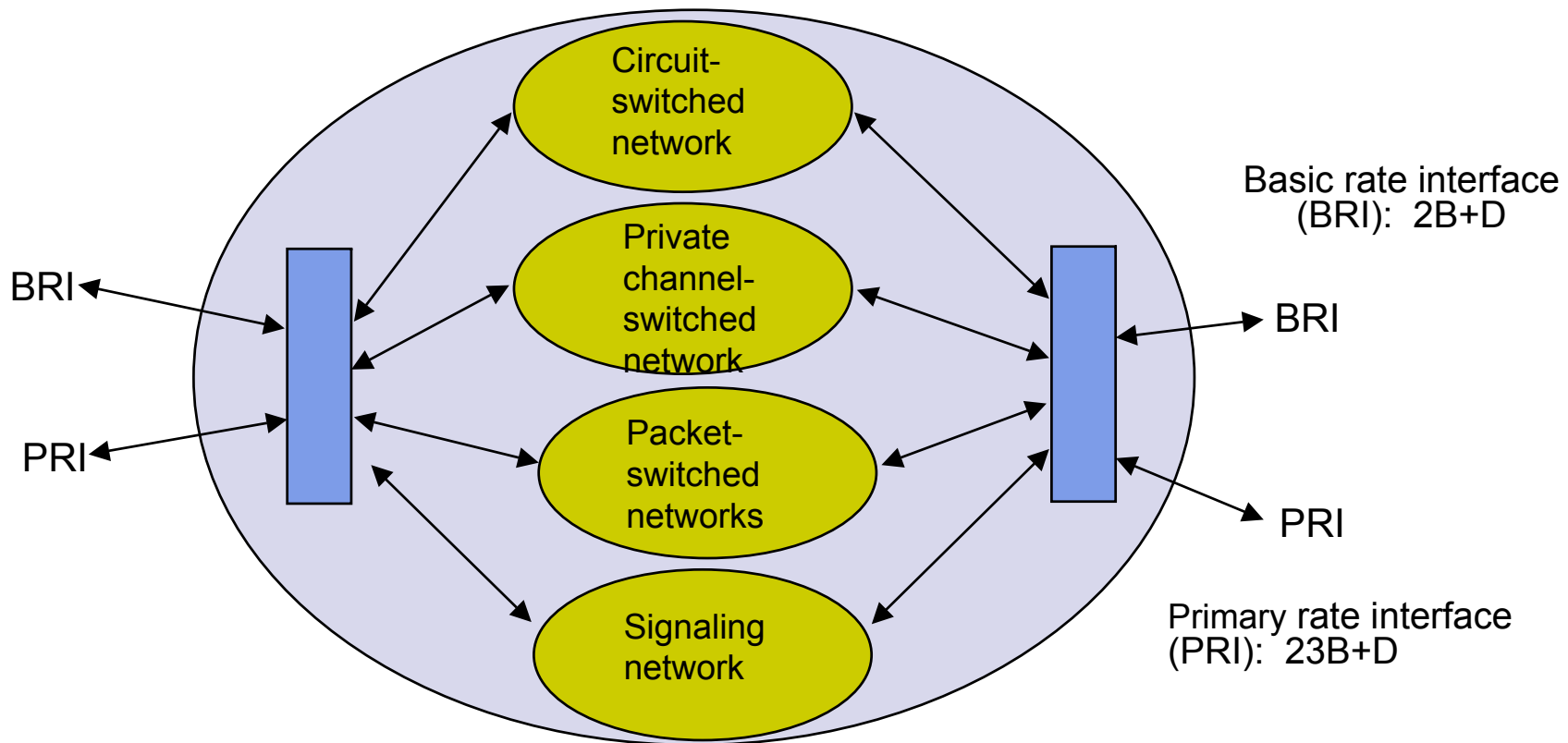

Chapter 4

Circuit-Switching Networks

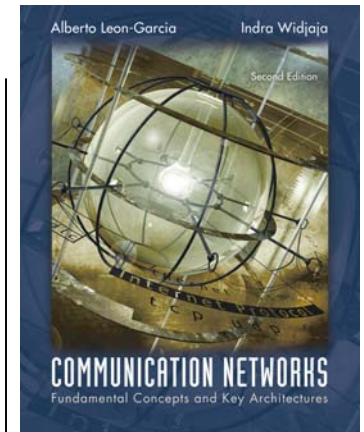

Signaling

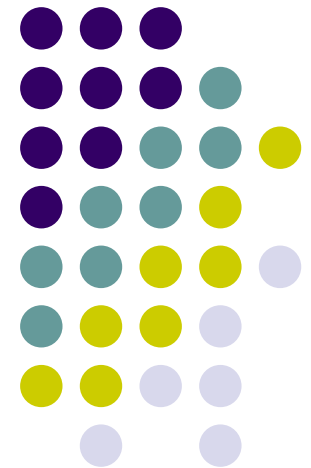

Setting Up Connections

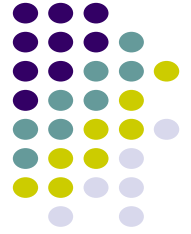

Manually

- Human Intervention
- Telephone
 - Voice commands & switchboard operators
- Transport Networks
 - Order forms & dispatching of craftpersons

Automatically

- Management Interface
 - Operator at console sets up connections at various switches
- Automatic signaling
 - Request for connection generates signaling messages that control connection setup in switches

Stored-Program Control Switches

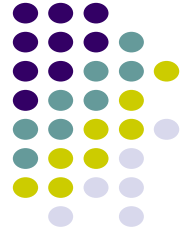

- SPC switches (1960s)
 - Crossbar switches with crossbars built from relays that open/close mechanically through electrical control
 - Computer program controls set up opening/closing of crosspoints to establish connections between switch inputs and outputs
- Signaling required to coordinate path set up across network

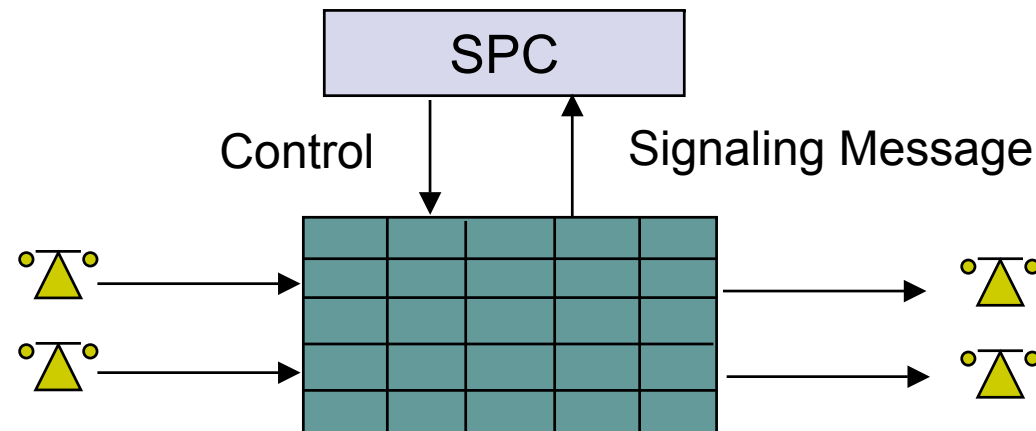

Message Signaling

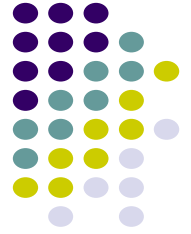

- Processors that control switches exchange signaling messages
- Protocols defining messages & actions defined
- Modems developed to communicate digitally over converted voice trunks

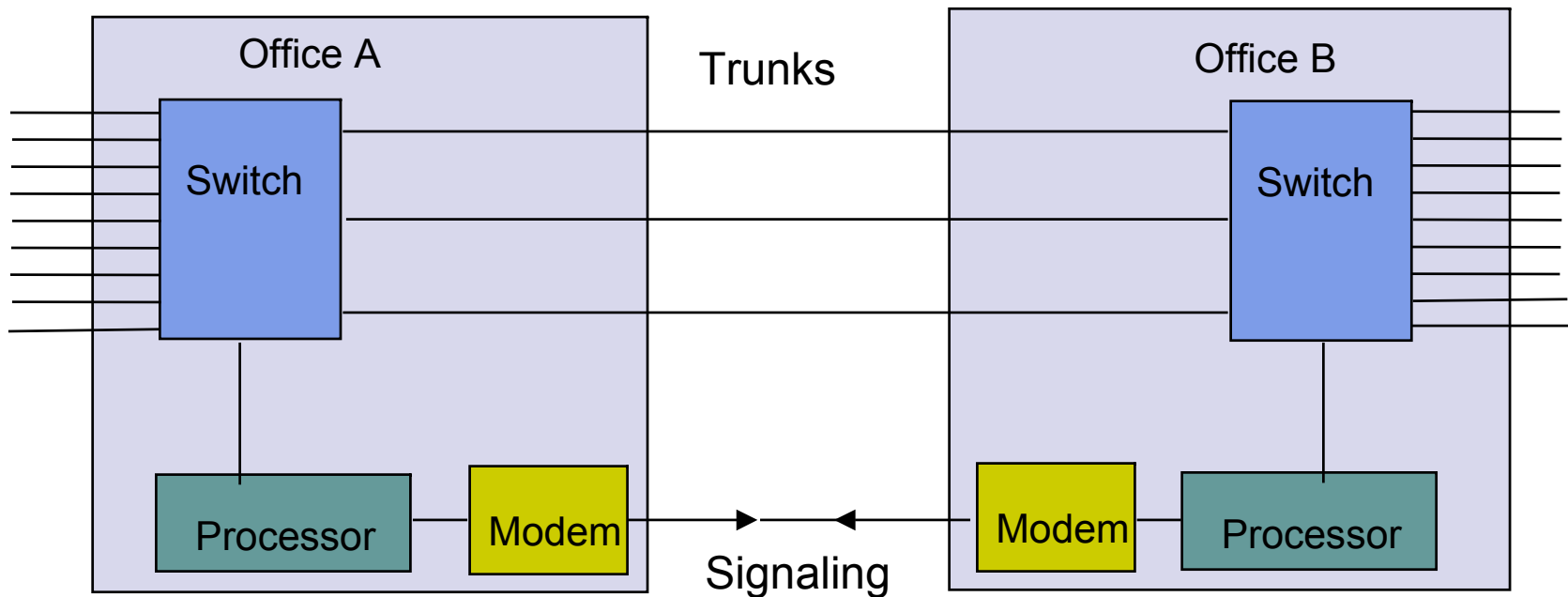



Signaling Network

- Common Channel Signaling (CCS) #7 deployed in 1970s to control call setup
- Protocol stack developed to support signaling
- Signaling network based on highly reliable packet switching network
- Processors & databases attached to signaling network enabled many new services: caller id, call forwarding, call waiting, user mobility

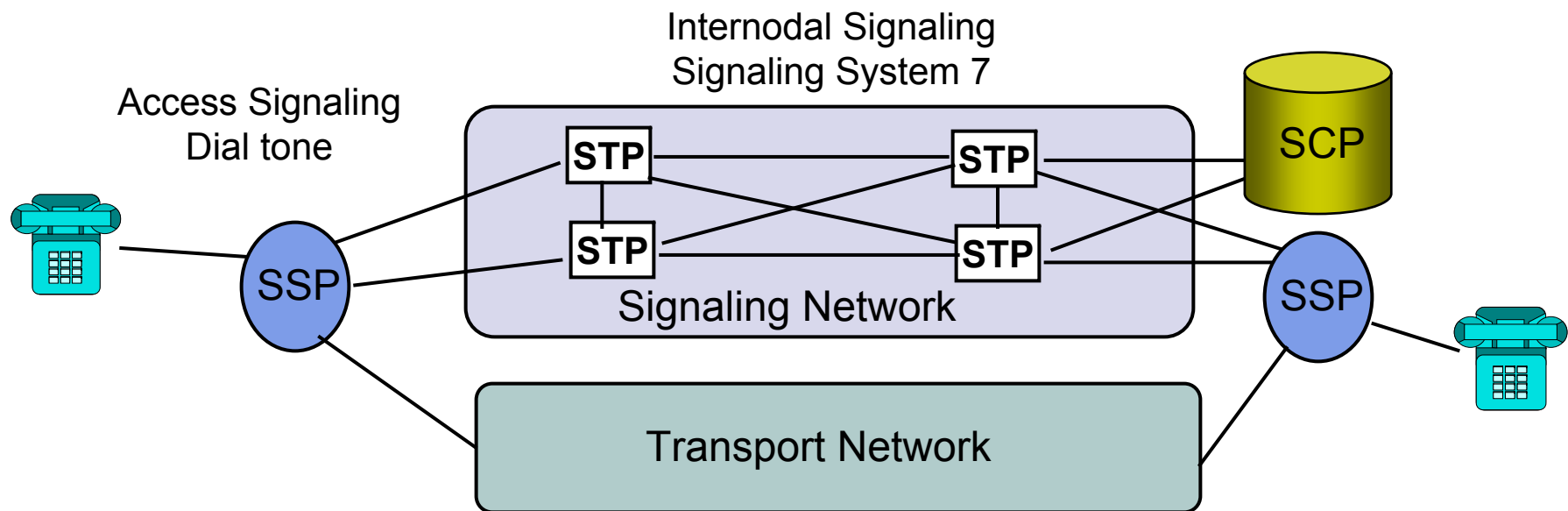

SSP = service switching point (signal to message)

STP = signal transfer point (packet switch)

SCP = service control point (processing)

Signaling System Protocol Stack

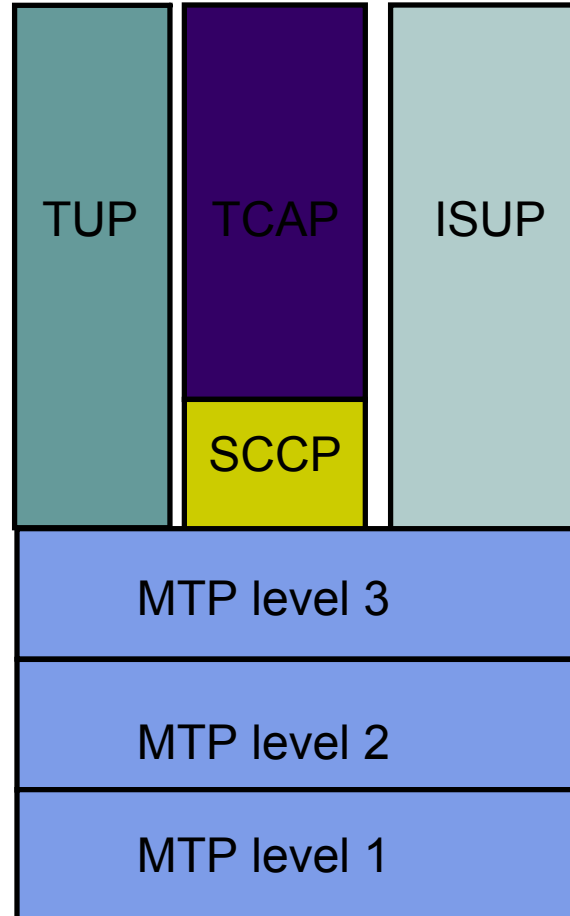
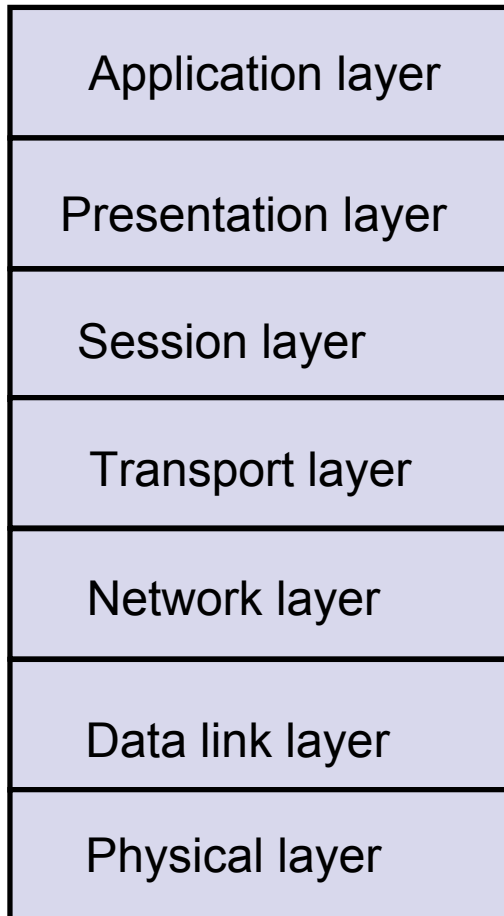
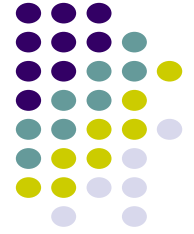

- Lower 3 layers ensure delivery of messages to signaling nodes
- SCCP allows messages to be directed to applications
- TCAP defines messages & protocols between applications
- ISUP performs basic call setup & release
- TUP instead of ISUP in some countries

ISUP = ISDN user part

SSCP = signaling connection control part

TUP = telephone user part

MTP = message transfer part

TCAP = transaction capabilities part

Future Signaling: Calls, Sessions, & Connections



Call/Session

- An agreement by two end parties to communicate
 - Answering a ringing phone (after looking at caller ID)
 - TCP three-way handshake
- Applies in connection-less & connection-oriented networks
- *Session Initiation Protocol (SIP)* provides for establishment of sessions in many Internet applications

Connection

- Allocation of resources to enable information transfer between communicating parties
 - Path establishment in telephone call
- Does not apply in connectionless networks
- *ReSerVation Protocol (RSVP)* provides for resource reservation along paths in Internet



Network Intelligence

- Intelligent Peripherals provide additional service capabilities
- Voice Recognition & Voice Synthesis systems allow users to access applications via speech commands
- “Voice browsers” currently under development (See: www.voicexml.org)
- Long-term trend is for IP network to replace signaling system and provide equivalent services
- Services can then be provided by telephone companies as well as new types of service companies

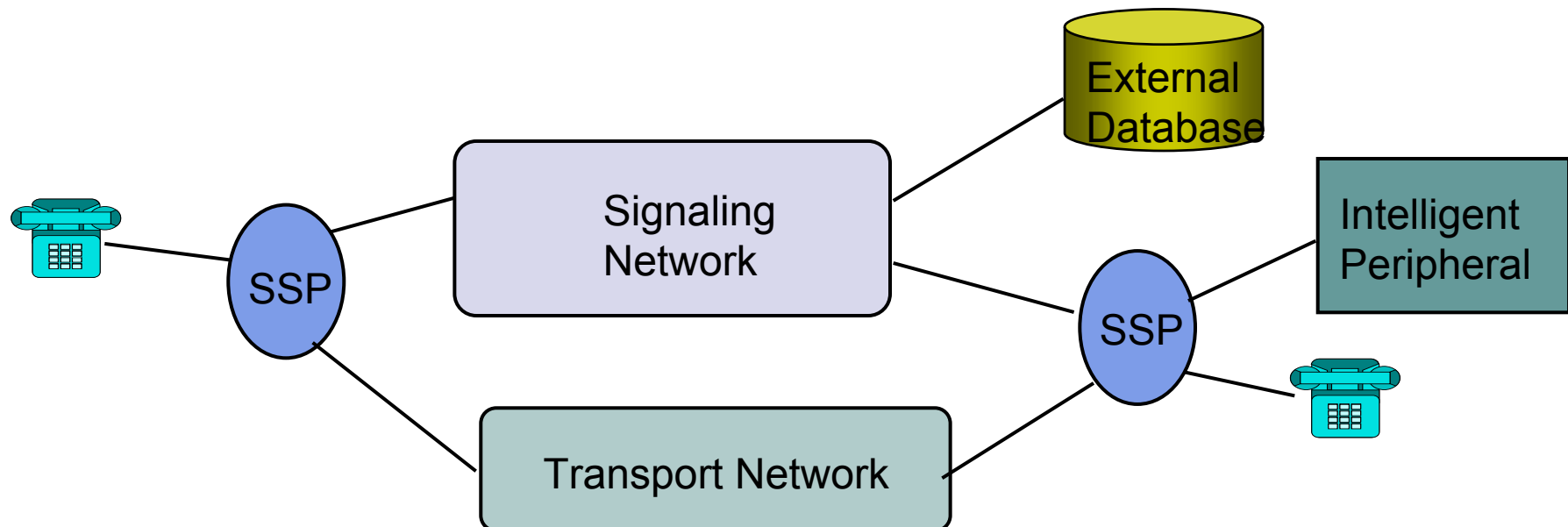

Chapter 4

Circuit-Switching Networks

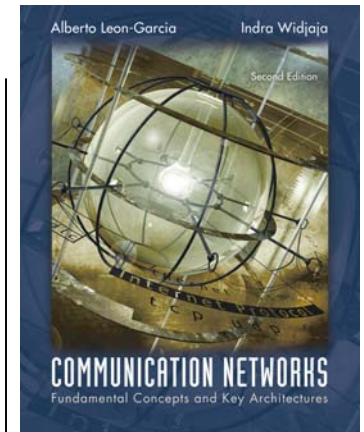

Traffic and Overload Control in Telephone Networks

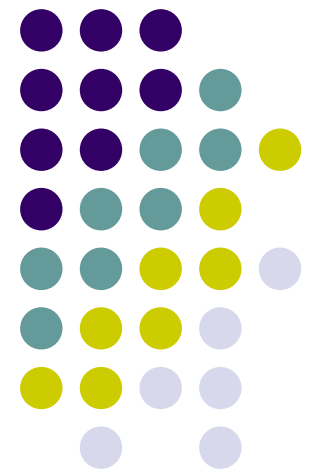

Traffic Management & Overload Control

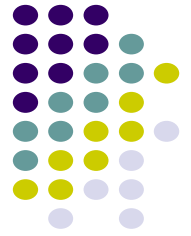

- Telephone calls come and go
- People activity follow patterns
 - Mid-morning & mid-afternoon at office
 - Evening at home
 - Summer vacation
- Outlier Days are extra busy
 - Mother's Day, Christmas, ...
- Disasters & other events cause surges in traffic
- Need traffic management & overload control

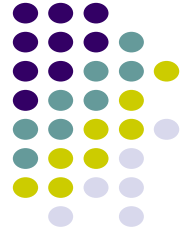

Traffic concentration

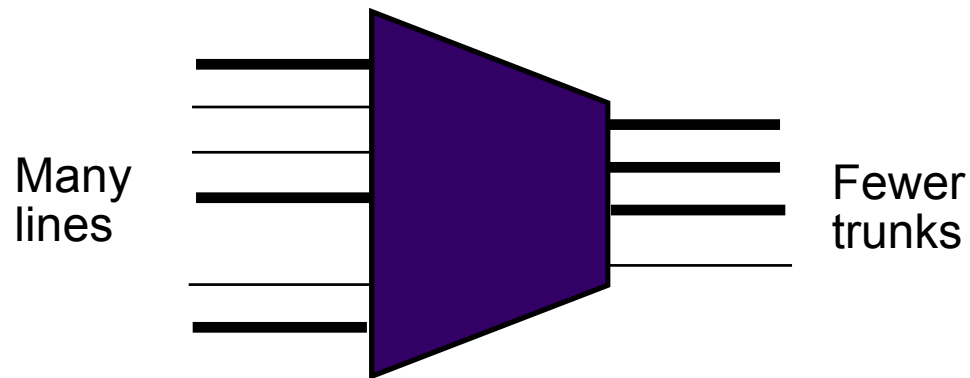

- Traffic fluctuates as calls initiated & terminated
 - Driven by human activity
- Providing resources so
 - Call requests *always* met is too expensive
 - Call requests met *most of the time* cost-effective
- Switches concentrate traffic onto *shared* trunks
 - Blocking of requests will occur from time to time
- Traffic engineering provisions resources to meet blocking performance targets

Fluctuation in Trunk Occupancy



Number of busy trunks

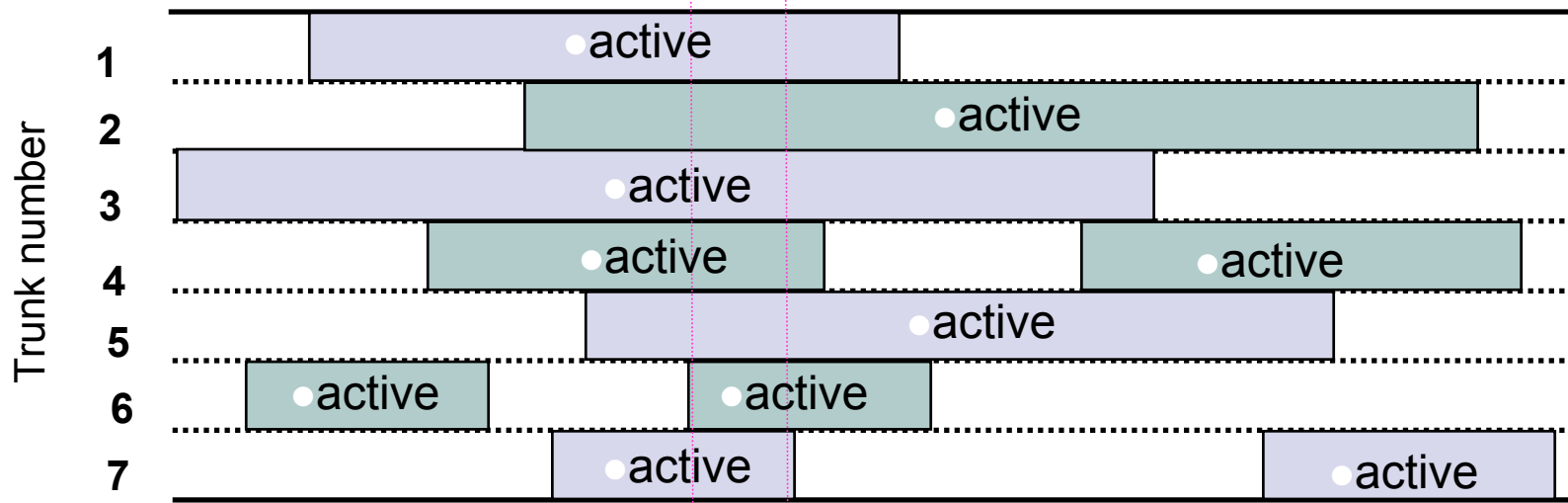
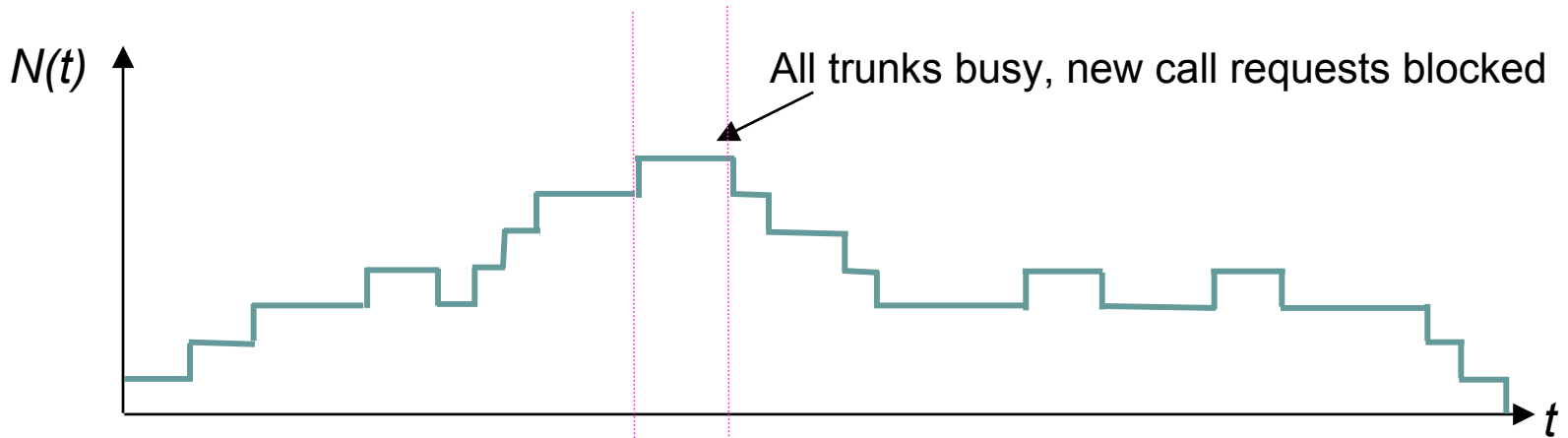

Modeling Traffic Processes



- Find the statistics of $N(t)$ the number of calls in the system

Model

- Call request **arrival rate**: λ requests per second
- In a very small time interval Δ ,
 - Prob[new request] = $\lambda\Delta$
 - Prob[no new request] = $1 - \lambda\Delta$
- The resulting random process is a Poisson arrival process:

$$\text{Prob}(k \text{ arrivals in time } T) = \frac{(\lambda T)^k e^{-\lambda T}}{k!}$$

- **Holding time**: Time a user maintains a connection
 - X a random variable with mean $E(X)$
- **Offered load**: rate at which work is offered by users:
 - $a = \lambda \text{ calls/sec} * E(X) \text{ seconds/call}$ (Erlangs)

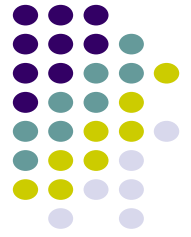

Blocking Probability & Utilization

- c = Number of Trunks
- Blocking occurs if all trunks are busy, i.e. $N(t)=c$
- If call requests are Poisson, then blocking probability P_b is given by **Erlang B Formula**

$$P_b = \frac{a^c / c!}{\sum_{k=0}^c a^k / k!}$$

- The *utilization* is the average # of trunks in use

$$\text{Utilization} = \lambda(1 - P_b) E[X]/c = (1 - P_b) a/c$$

Blocking Performance

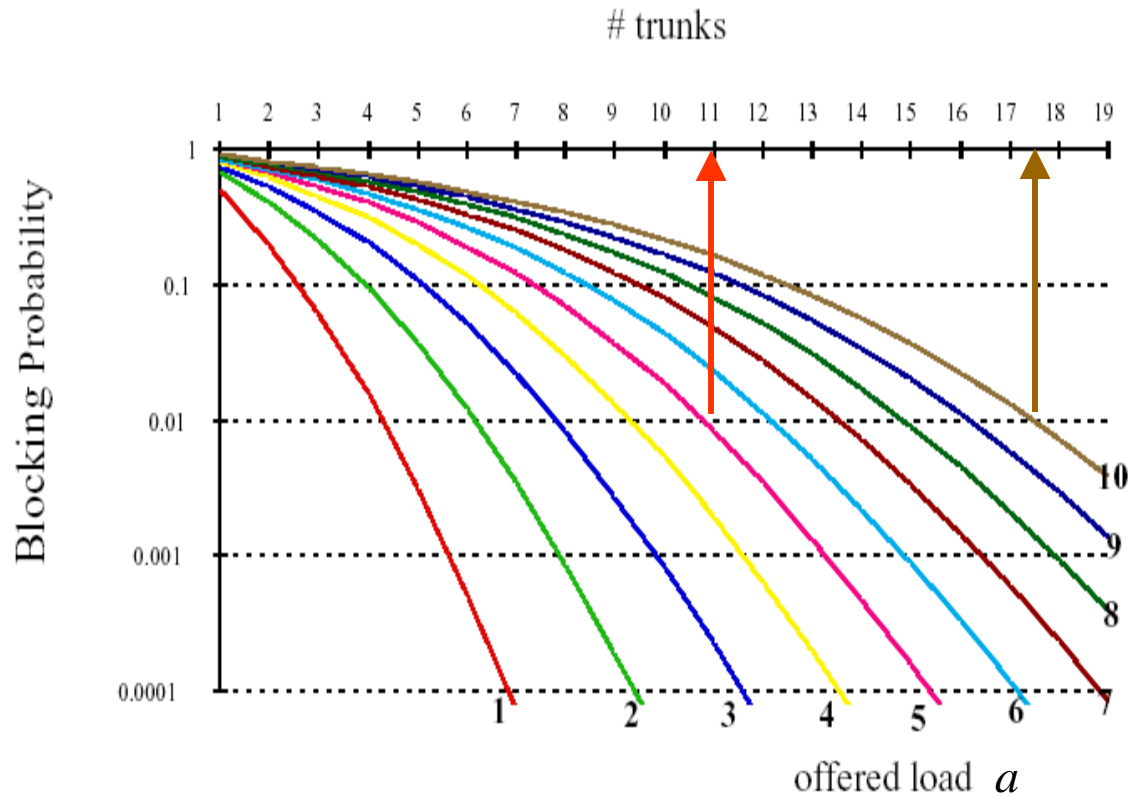

To achieve 1% blocking probability:

$a = 5$ Erlangs requires 11 trunks

$a = 10$ Erlangs requires 18 trunks



Multiplexing Gain

Load	Trunks@1%	Utilization
1	5	0.20
2	7	0.29
3	8	0.38
4	10	0.40
5	11	0.45
6	13	0.46
7	14	0.50
8	15	0.53
9	17	0.53
10	18	0.56
30	42	0.71
50	64	0.78
60	75	0.80
90	106	0.85
100	117	0.85

- At a given P_b , the system becomes more efficient in utilizing trunks with increasing system size
- Aggregating traffic flows to share centrally allocated resources is more efficient
- This effect is called *Multiplexing Gain*

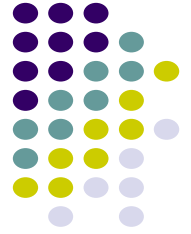

Routing Control

- Routing control: selection of connection paths
- Large traffic flows should follow direct route because they are efficient in use of resources
- Useful to combine smaller flows to share resources
- Example: 3 close CO's & 3 other close COs
- 10 Erlangs between each pair of COs

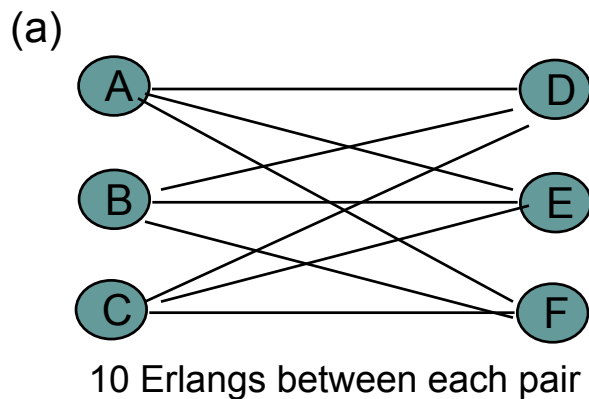

17 trunks for 10 Erlangs
 $9 \times 17 = 153$ trunks
Efficiency = $90/153 = 53\%$

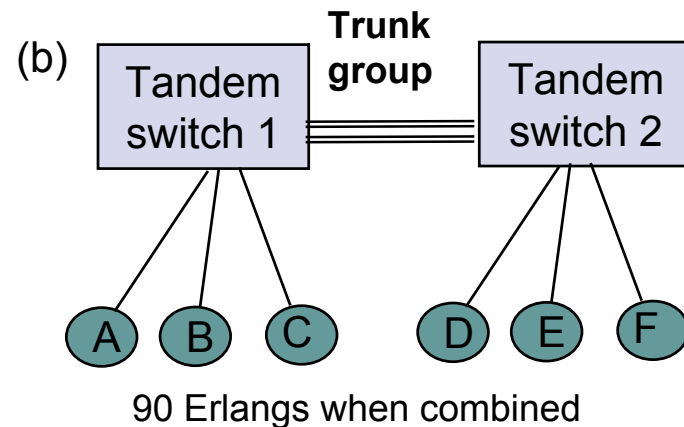

106 trunks for 90 Erlangs
Efficiency = 85%

Alternative Routing

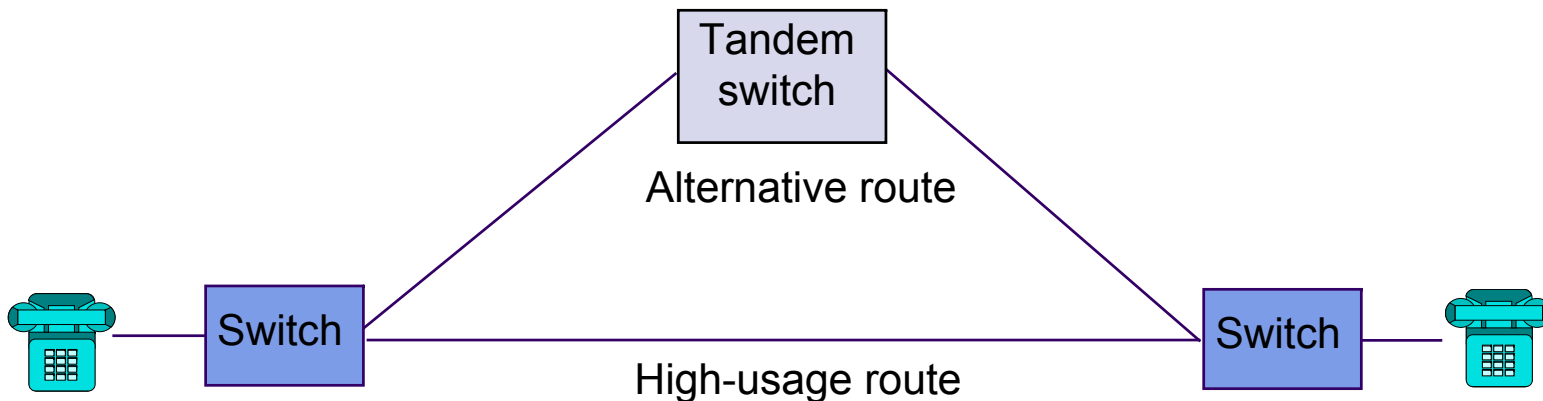
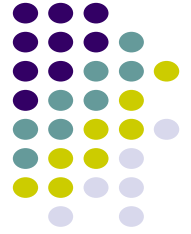

- Deploy trunks between switches with significant traffic volume
- Allocate trunks with high blocking, say 10%, so utilization is high
- Meet 1% end-to-end blocking requirement by overflowing to longer paths over tandem switch
- Tandem switch handles overflow traffic from other switches so it can operate efficiently
- Typical scenario shown in next slide

Typical Routing Scenario

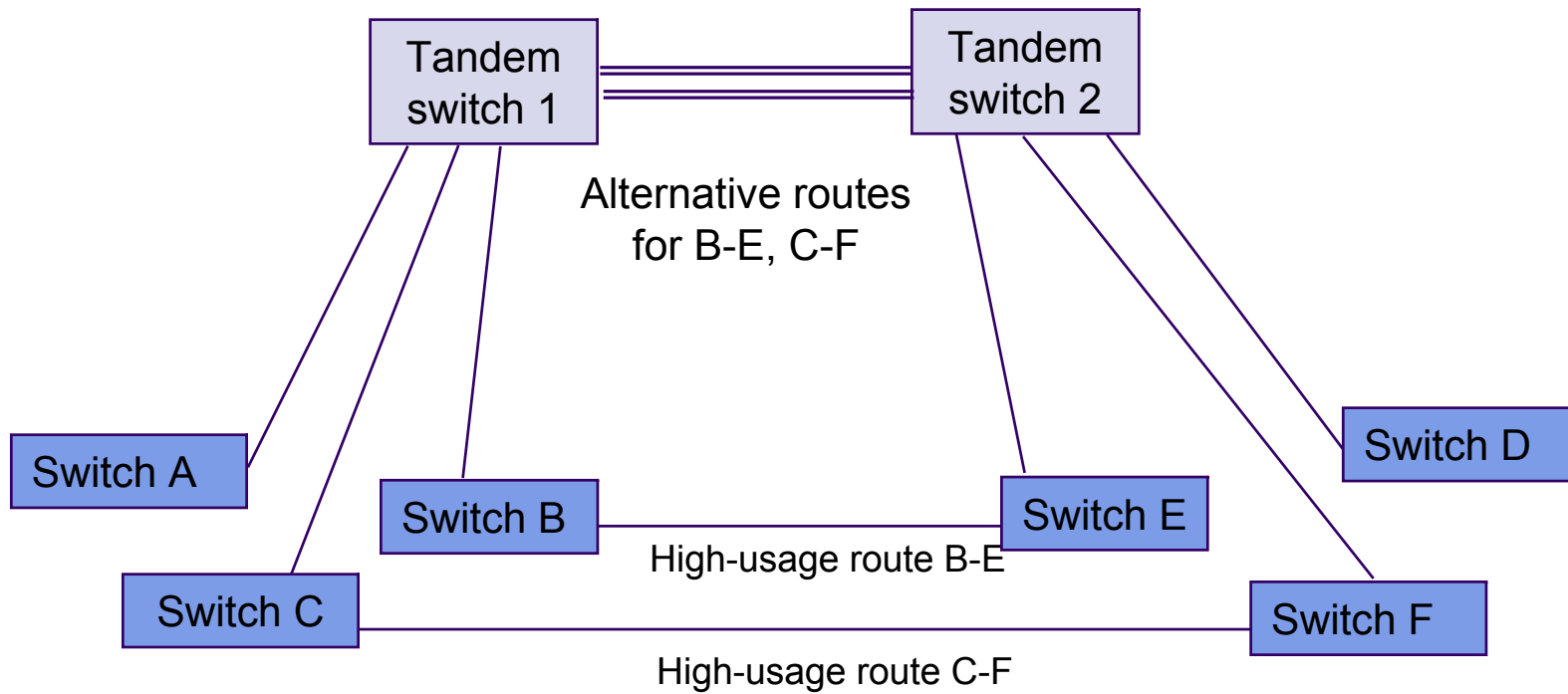

Dynamic Routing

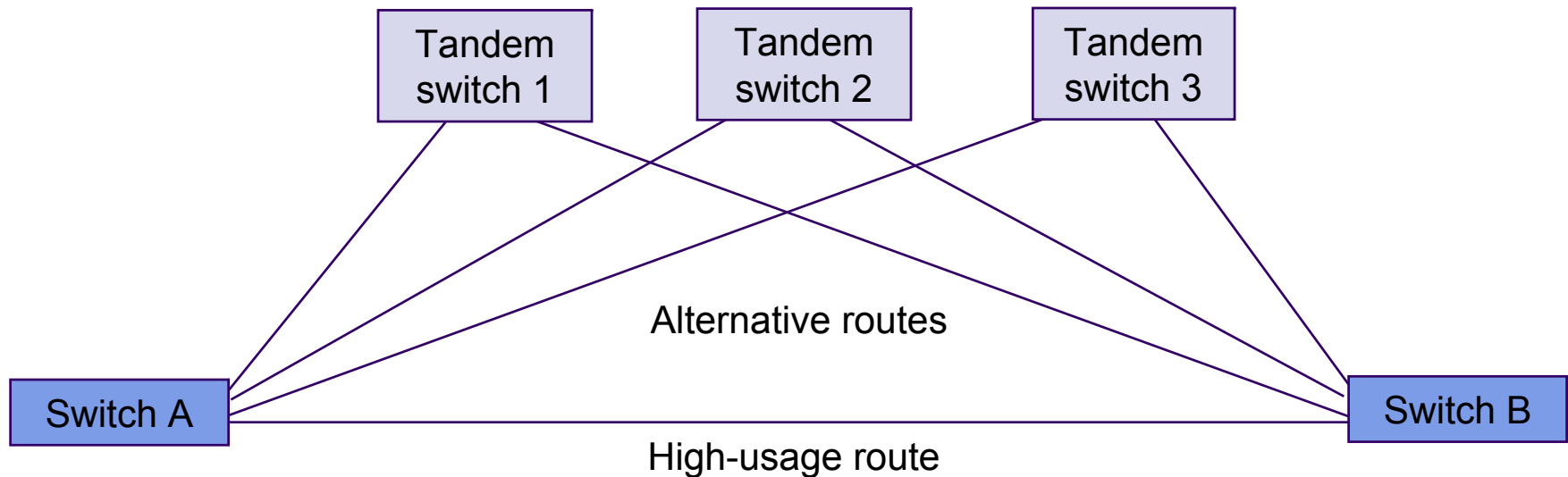

- Traffic varies according to time of day, day of week
 - East coast of North America busy while West coast idle
- Network can use idle resources by adapting route selection dynamically
 - Route some intra-East-coast calls through West-coast switches
- Try high-usage route and overflow to alternative routes

Overload Control

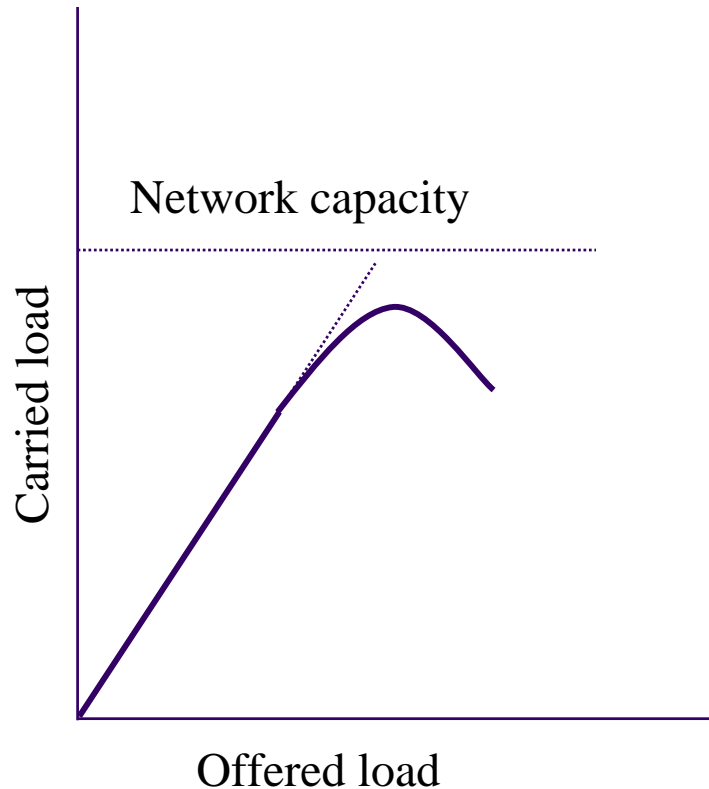

Overload Situations

- Mother's Day, Xmas
- Catastrophes
- Network Faults

Strategies

- Direct routes first
- Outbound first
- Code blocking
- Call request pacing

Chapter 4

Circuit-Switching Networks

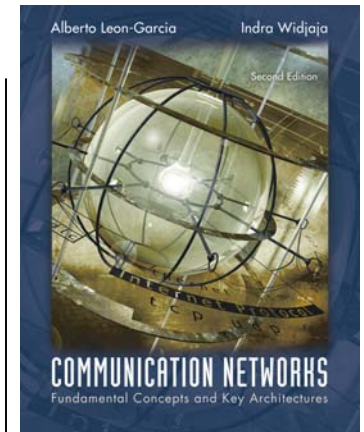

Cellular Telephone Networks

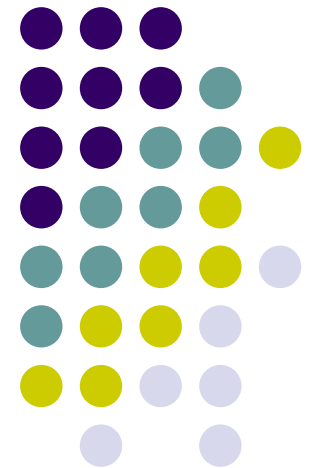

Radio Communications

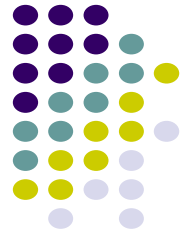

- 1900s: Radio telephony demonstrated
- 1920s: Commercial radio broadcast service
- 1930s: Spectrum regulation introduced to deal with interference
- 1940s: Mobile Telephone Service
 - Police & ambulance radio service
 - Single antenna covers transmission to mobile users in city
 - Less powerful car antennas transmit to network of antennas around a city
 - Very limited number of users can be supported

Cellular Communications

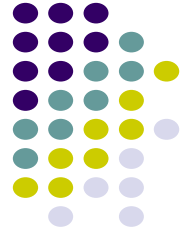

Two basic concepts:

- Frequency Reuse
 - A region is partitioned into *cells*
 - Each cell is covered by *base station*
 - Power transmission levels controlled to minimize inter-cell interference
 - Spectrum can be reused in other cells
- Handoff
 - Procedures to ensure continuity of call as user moves from cell to another
 - Involves setting up call in new cell and tearing down old one

Frequency Reuse

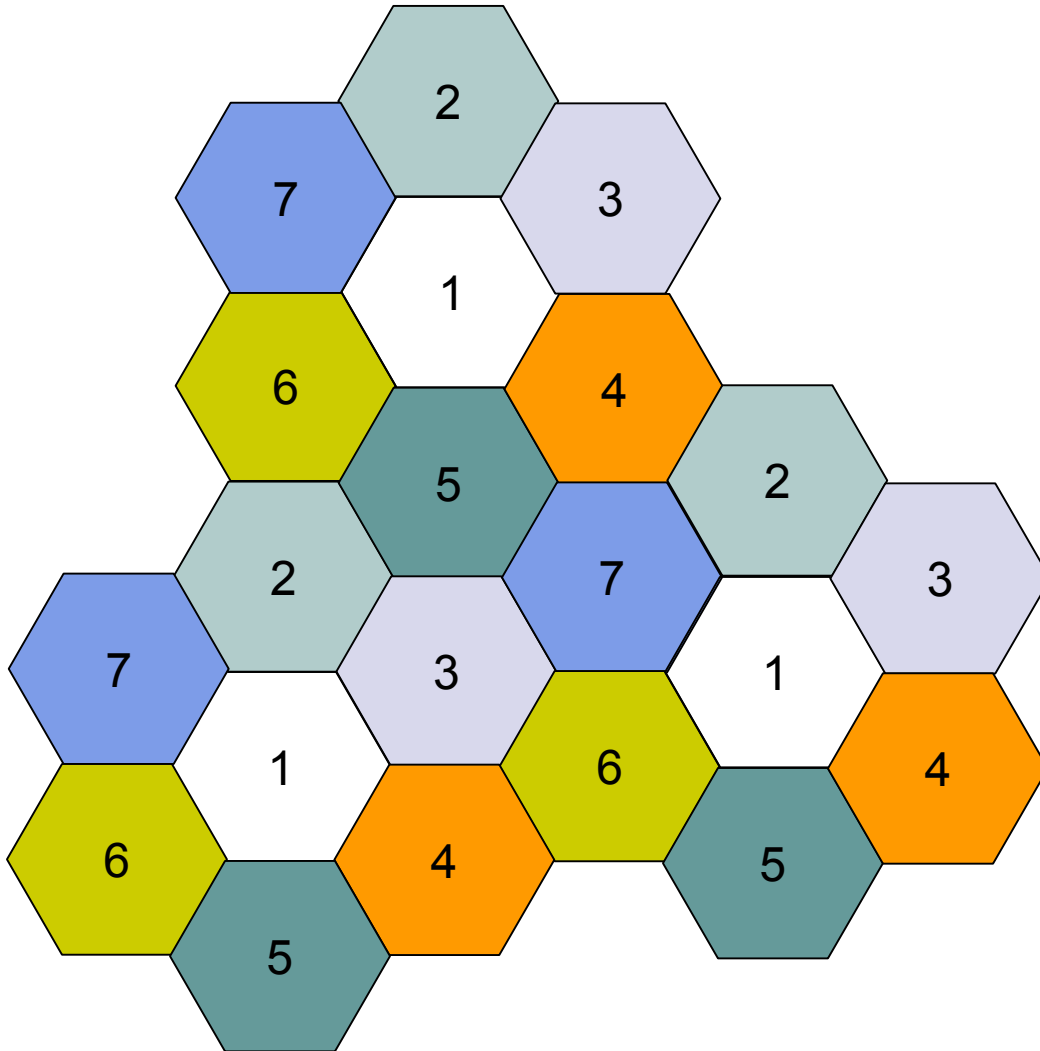
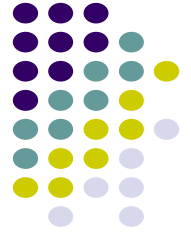

- Adjacent cells may not use same band of frequencies
- Frequency Reuse Pattern specifies how frequencies are reused
- Figure shows 7-cell reuse: frequencies divided into 7 groups & reused as shown
- Also 4-cell & 12-cell reuse possible
- Note: CDMA allows adjacent cells to use same frequencies (Chapter 6)

Cellular Network

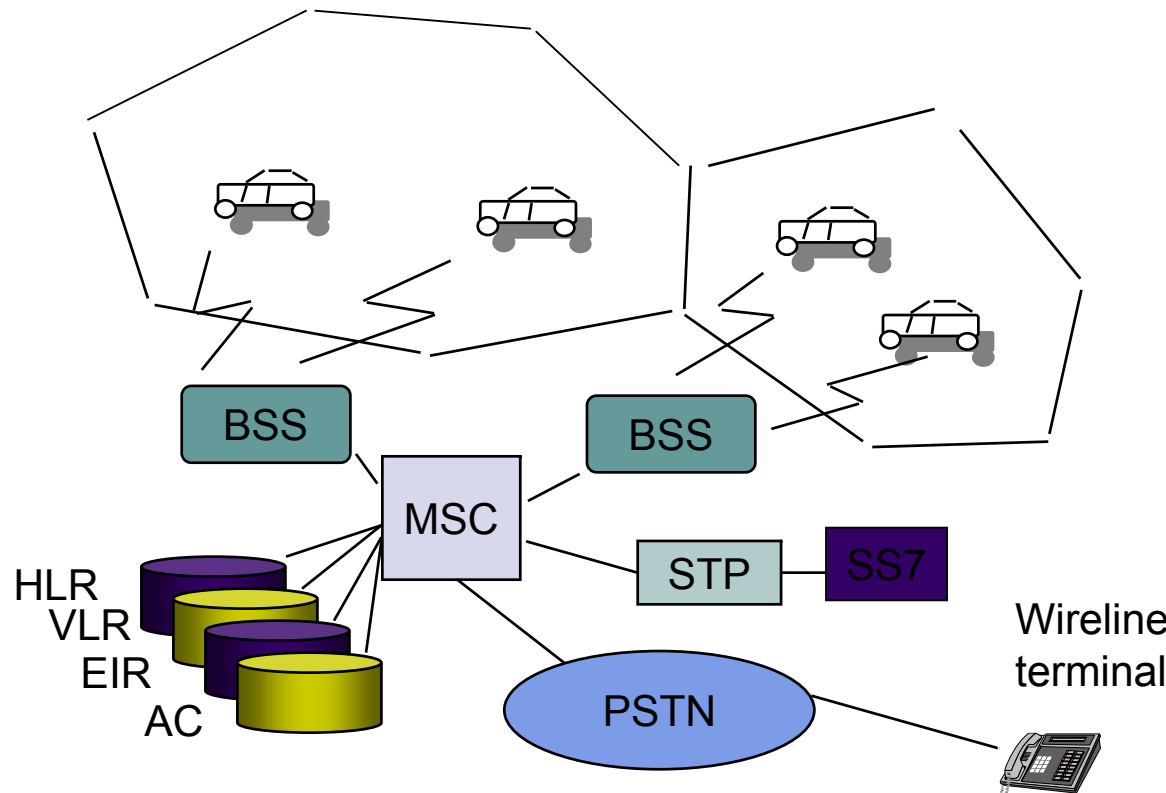

Base station

- Transmits to users on *forward channels*
- Receives from users on *reverse channels*

Mobile Switching Center

- Controls connection setup within cells & to telephone network

AC = authentication center
BSS = base station subsystem
EIR = equipment identity register
HLR = home location register

MSC = mobile switching center
PSTN = public switched telephone network
STP = signal transfer point
VLR = visitor location register

Signaling & Connection Control

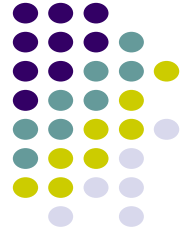

- *Setup channels* set aside for call setup & handoff
 - Mobile unit selects setup channel with strongest signal & monitors this channel
- **Incoming call to mobile unit**
 - MSC sends call request to all BSSs
 - BSSs broadcast request on all setup channels
 - Mobile unit replies on reverse setup channel
 - BSS forwards reply to MSC
 - BSS assigns forward & reverse voice channels
 - BSS informs mobile to use these
 - Mobile phone rings

Mobile Originated Call



- Mobile sends request in reverse setup channel
- Message from mobile includes serial # and possibly authentication information
- BSS forwards message to MSC
- MSC consults Home Location Register for information about the subscriber
- MSC may consult Authentication center
- MSC establishes call to PSTN
- BSS assigns forward & reverse channel

Handoff



- Base station monitors signal levels from its mobiles
- If signal level drops below threshold, MSC notified & mobile instructed to transmit on setup channel
- Base stations in vicinity of mobile instructed to monitor signal from mobile on setup channel
- Results forward to MSC, which selects new cell
- Current BSS & mobile instructed to prepare for handoff
- MSC releases connection to first BSS and sets up connection to new BSS
- Mobile changes to new channels in new cell
- Brief interruption in connection (except for CDMA)

Roaming



- Users subscribe to roaming service to use service outside their home region
- Signaling network used for message exchange between home & visited network
- Roamer uses setup channels to register in new area
- MSC in visited areas requests authorization from users Home Location Register
- Visitor Location Register informed of new user
- User can now receive & place calls

GSM Signaling Standard



- Base station
 - Base Transceiver Station (BTS)
 - Antenna + Transceiver to mobile
 - Monitoring signal strength
 - Base Station Controller
 - Manages radio resources or 1 or more BTSs
 - Set up of channels & handoff
 - Interposed between BTS & MSC
- Mobile & MSC Applications
 - Call Management (CM)
 - Mobility Management (MM)
- Radio Resources Management (RRM) concerns mobile, BTS, BSC, and MSC

Cellular Network Protocol Stack

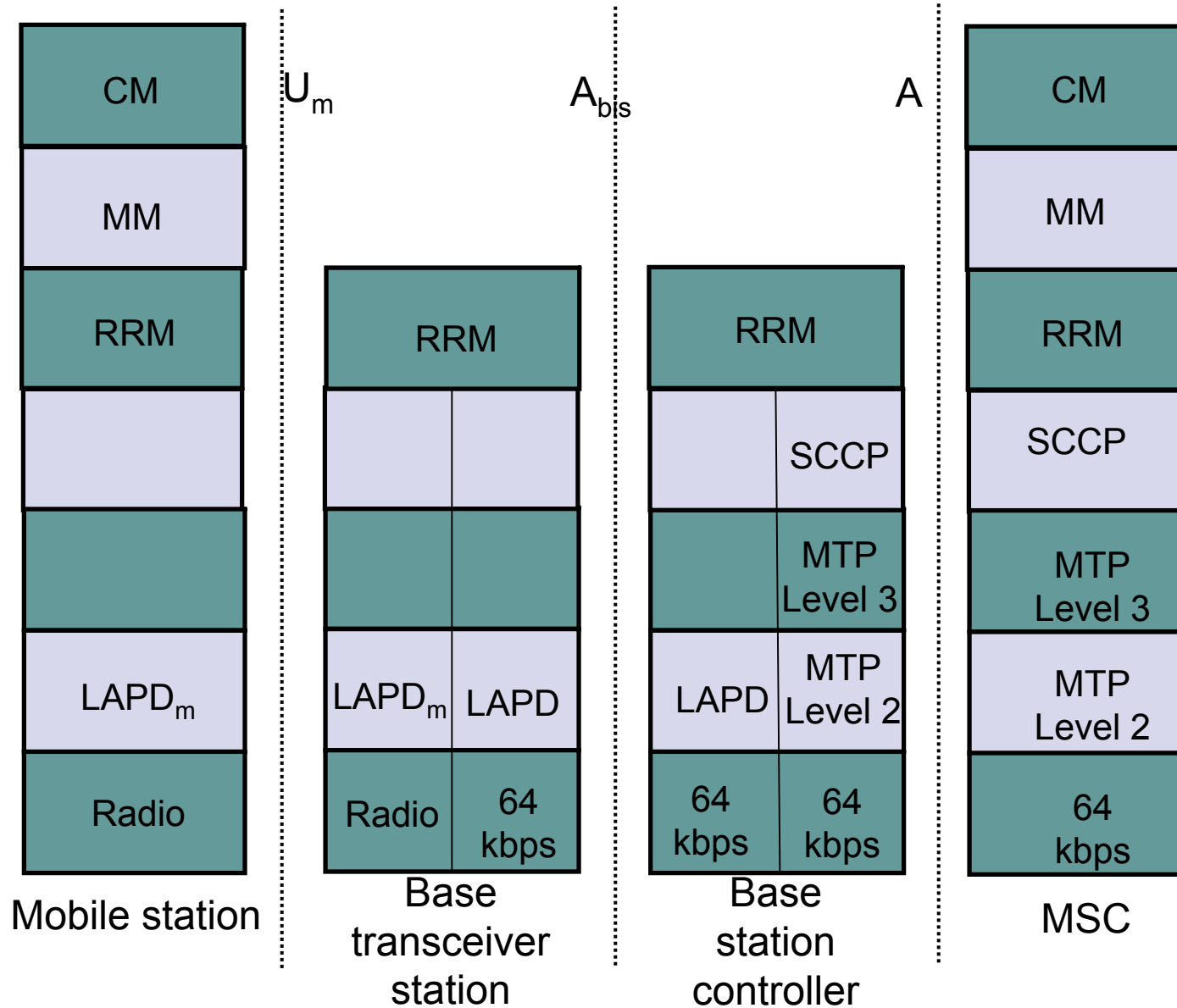

Cellular Network Protocol Stack

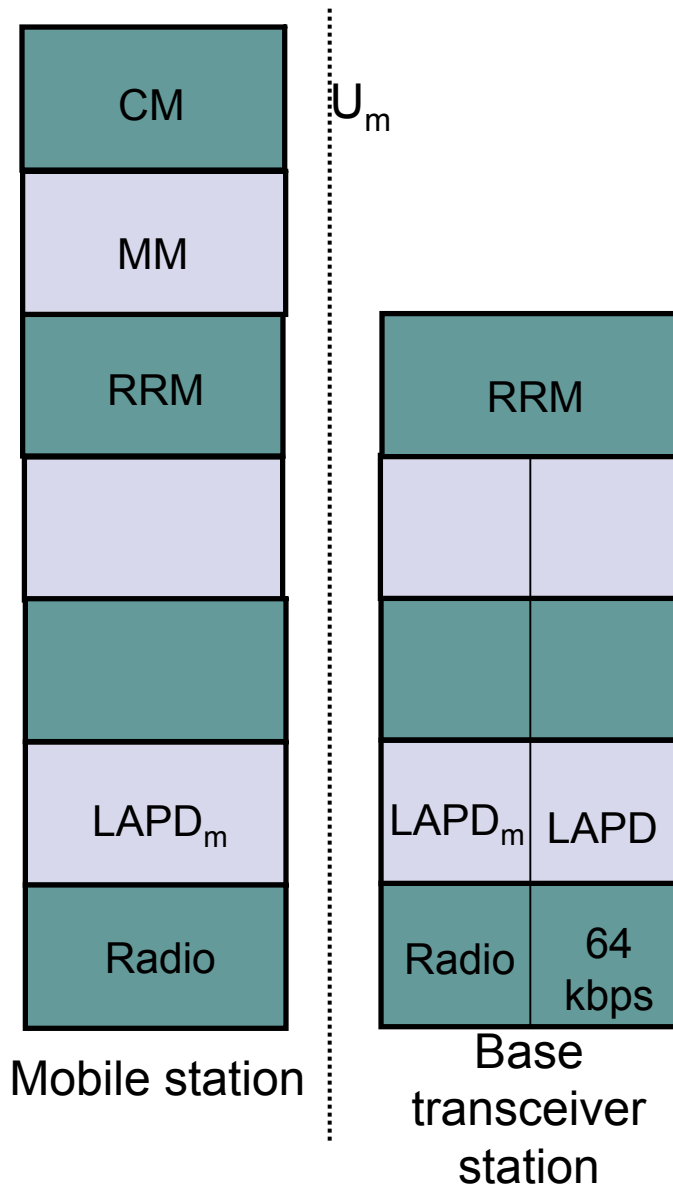

Radio Air Interface (U_m)

- LAPD_m is data link control adapted to mobile
- RRM deals with setting up of radio channels & handover

Cellular Network Protocol Stack

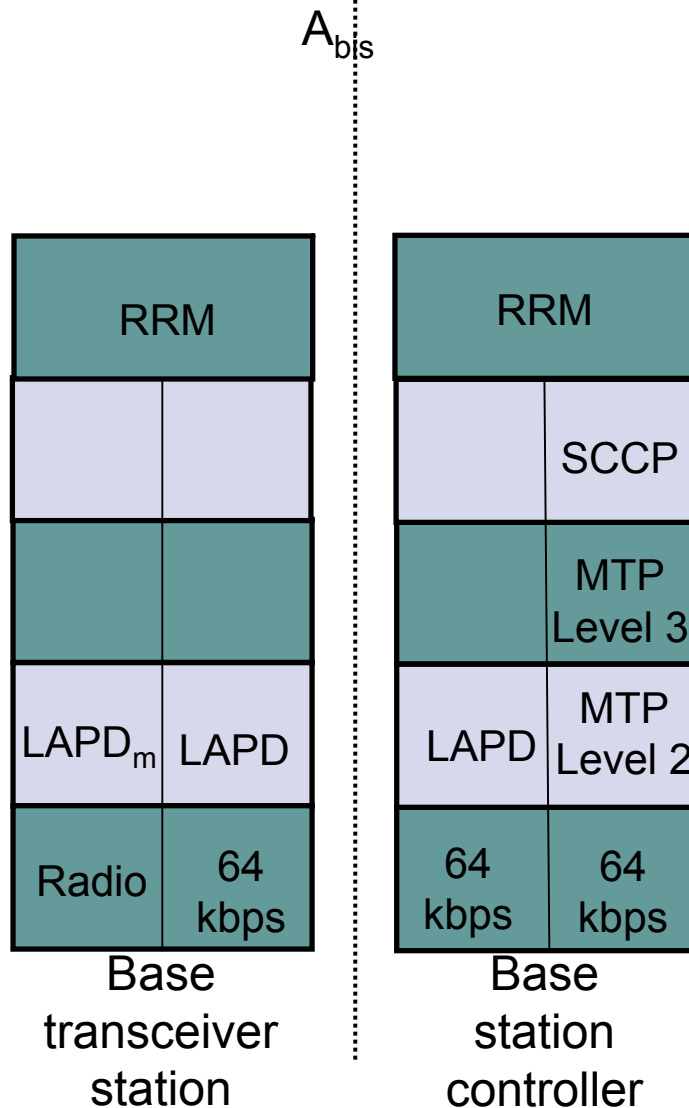

A_{bis} Interface

- 64 kbps link physical layer
- LAPD_m
- BSC RRM can handle handover for cells within its control

Cellular Network Protocol Stack

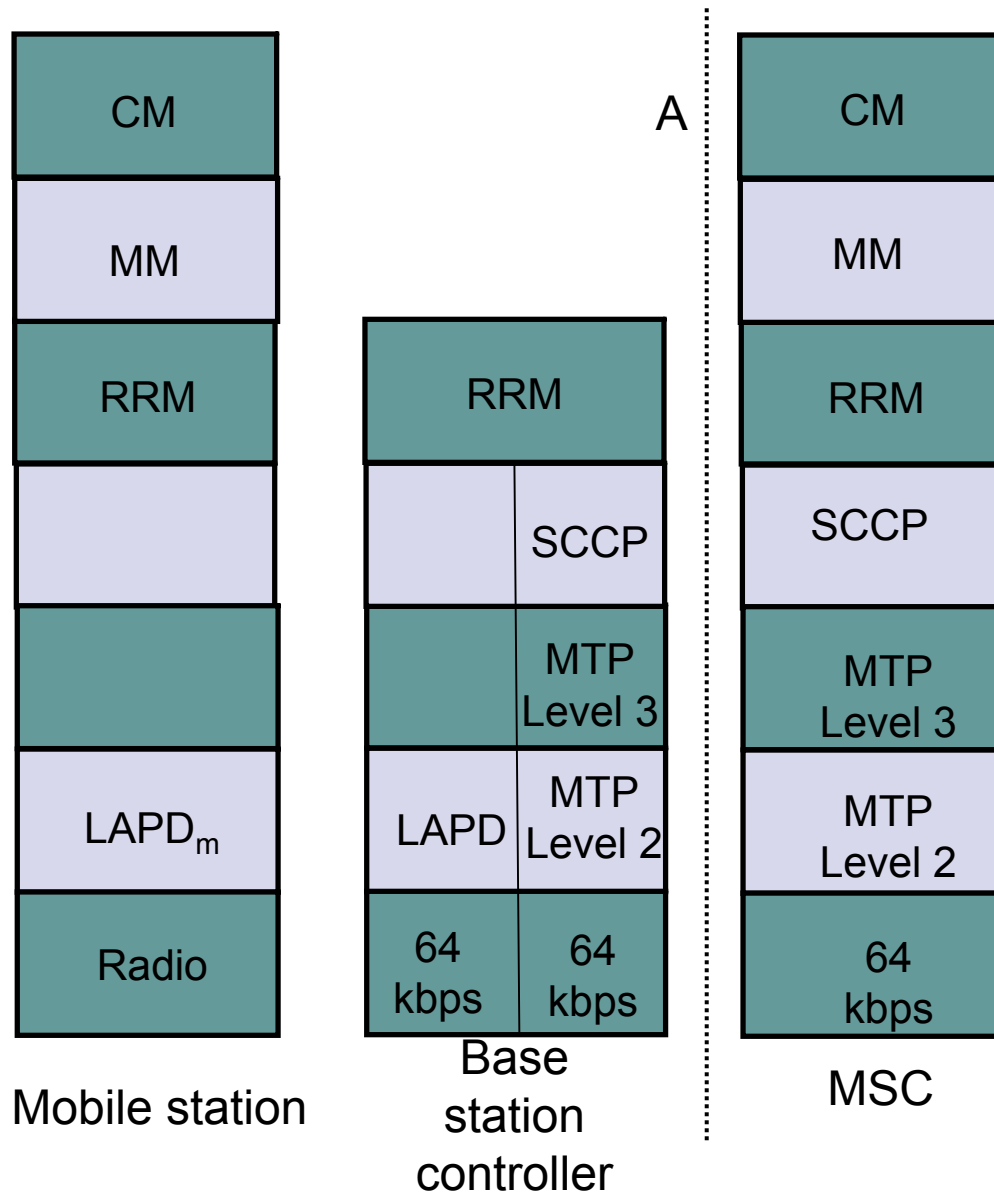

Signaling Network (A) Interface

- RRM deals handover involving cells with different BSCs
- MM deals with mobile user location, authentication
- CM deals with call setup & release using modified ISUP

What's Next for Cellular Networks?



- Mobility makes cellular phone compelling
 - Cell phone use increasing at expense of telephone
- Short Message Service (SMS) transfers text using signaling infrastructure
 - Growing very rapidly
- Multimedia cell phones
 - Digital camera to stimulate more usage
- Higher speed data capabilities
 - GPRS & EDGE for data transfer from laptops & PDAs
 - WiFi (802.11 wireless LAN) a major competitor